

MARINE CORPS INSTITUTE

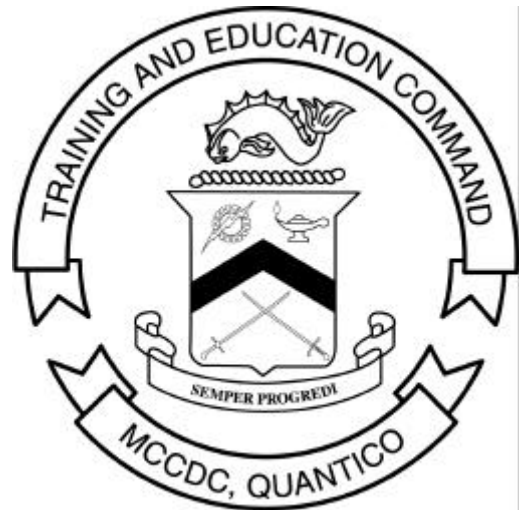

ANTENNA CONSTRUCTION AND PROPAGATION OF RADIO WAVES

MARINE BARRACKS
WASHINGTON, DC



UNITED STATES MARINE CORPS

MARINE CORPS INSTITUTE
912 POOR STREET S. E.
WASHINGTON NAVY YARD DC 20391-5680

IN REPLY REFER TO:

1550

Ser 2515

10 July 01

From: Director
To: Marine Corps Institute Student

Subj: ANTENNA CONSTRUCTION AND PROPAGATION OF RADIO WAVES
(MCI 2515H)

1. Purpose. The MCI 2515H, *Antenna Construction and Propagation of Radio Waves*, provides communicators with instructions in selecting and/or constructing the appropriate antenna(s) for use within the current field.
2. Scope. This course is designed as a course of study on the propagation of radio waves and the construction and repair of conventional and field expedient antennas.
3. Applicability. This course is intended for instructional purposes only. This course is designed for Marines in the ranks of private through gunnery sergeant in occupational fields 2500 and 2800.
4. Recommendations. Comments and recommendations on the contents of the course are invited and will aid in subsequent course revisions. Please complete the course evaluation questionnaire at the end of the final examination. Return the questionnaire and the examination booklet to your proctor.

G. E. GEARHARD
Deputy

(This page intentionally left blank.)

Table of Contents

	Page
Contents.....	i
Student Information	iii
Study Guide.....	v
Study Unit 1 Radio Communications	1-1
Lesson 1 Radio Sets and Waves	1-3
Lesson 2 Carrier Waves and Modulation.....	1-13
Study Unit 2 Propagation of Radio Waves	2-1
Lesson 1 The Atmosphere.....	2-3
Lesson 2 Ground Waves and Sky Waves.....	2-15
Lesson 3 Maximum Usable Frequency (MUF) and Lowest Usable Frequencies (LUF)	2-23
Lesson 4 Fading	2-29
Lesson 5 The Effects of Frequency on Wave Propagation	2-37
Study Unit 3 Antennas	3-1
Lesson 1 Functions of an Antenna and Antenna Radiation	3-3
Lesson 2 Antenna Polarization	3-11
Lesson 3 Conventional Antennas	3-21
Lesson 4 Field Expedient Antennas.....	3-33
Lesson 5 Transmission Lines	3-47
Study Unit 4 Site Selection and Antenna Grounding	4-1
Lesson 1 Requirements for Site Selection.....	4-3
Lesson 2 Electronic Warfare Considerations	4-11
Lesson 3 Grounds and Counterpoises	4-17
Appendix A Field Expedient Antenna Construction	A-1
Appendix B Joint Spectrum Center (JSC)	B-1
Review Lesson.....	R-1

(This page intentionally left blank.)

Student Information

Number and Title MCI 25.15h
ANTENNA CONSTRUCTION AND PROPAGATION OF RADIO WAVES

Study Hours 11

Course Materials Text

Review Agency Marine Corps Communications-Electronic School, Marine Corps Air Ground Combat Center, Twentynine Palms, CA 92278

Reserve Retirement Credits (RRC) 4

ACE Not applicable to civilian training/education

Assistance For administrative assistance, have your training officer or NCO log on to the MCI home page at www.mci.usmc.mil to access the Unit Verification Report (UVR) or MCI *Hotline*. Marines CONUS may call toll free 1-800-MCI-USMC. Marines worldwide may call commercial (202) 685-7596 or DSN 325-7596.

For assistance concerning course content matters, call the Distance Learning Technologies Department's Support Division at DSN 325-7516 or commercial (202) 685-7516, or log on to the MCI home page at www.mci.usmc.mil/feedback/course_developers.

(This page intentionally left blank.)

Study Guide

Congratulations Congratulations on your enrollment in a distance training course from the Distance Learning Technology Department (DLTD) of the Marine Corps Institute (MCI). Since 1920, the Marine Corps Institute has been helping tens of thousands of hard-charging Marines, like you, improve their technical job performance skills through distance training. By enrolling in this course, you have shown a desire to improve the skills you have and master new skills to enhance your job performance. The distance training course you have chosen, MCI 2515H, *Antenna Construction and Propagation of Radio Waves*, provides communicators with instructions in selecting and/or constructing the appropriate antenna(s) for use within the current field.

Your Personal Characteristics

- **YOU ARE PROPERLY MOTIVATED.** You have made a positive decision to get training on your own. Self-motivation is perhaps the most important force in learning or achieving anything. Doing whatever is necessary to learn is motivation. You have it!
- **YOU SEEK TO IMPROVE YOURSELF.** You are enrolled to improve those skills you already possess, and to learn new skills. When you improve yourself, you improve the Corps!
- **YOU HAVE THE INITIATIVE TO ACT.** By acting on your own, you have shown you are a self-starter, willing to reach out for opportunities to learn and grow.
- **YOU ACCEPT CHALLENGES.** You have self-confidence and believe in your ability to acquire knowledge and skills. You have the self-confidence to set goals and the ability to achieve them, enabling you to meet every challenge.
- **YOU ARE ABLE TO SET AND ACCOMPLISH PRACTICAL GOALS.** You are willing to commit time, effort, and the resources necessary to set and accomplish your goals. These professional traits will help you successfully complete this distance training course.

Continued on next page

Study Guide, Continued

Beginning Your Course Before you actually begin this course of study, read the student information page. If you find any course materials missing, notify your training officer or training NCO. If you have all the required materials, you are ready to begin.

To begin your course of study, familiarize yourself with the structure of the course text. One way to do this is to read the table of contents. Notice the table of contents covers specific areas of study and the order in which they are presented. You will find the text divided into several study units. Each study unit is comprised of two or more lessons and lesson exercises.

Leafing Through the Text Leaf through the text and look at the course. Read a few lesson exercise questions to get an idea of the type of material in the course. If the course has additional study aids, such as a handbook or plotting board, familiarize yourself with them.

The First Study Unit Turn to the first page of study unit 1. On this page, you will find an introduction to the study unit and generally the first study unit lesson. Study unit lessons contain learning objectives, lesson text, and exercises.

Reading the Learning Objectives Learning objectives describe in concise terms what the successful learner, you, will be able to do as a result of mastering the content of the lesson text. Read the objectives for each lesson and then read the lesson text. As you read the lesson text, make notes on the points you feel are important.

Completing the Exercises To determine your mastery of the learning objectives and text, complete the exercises developed for you. Exercises are located at the end of each lesson, and at the end of each study unit. Without referring to the text, complete the exercise questions and then check your responses against those provided.

Continued on next page

Study Guide, Continued

Continuing to March

Continue on to the next lesson, repeating the above process until you have completed all lessons in the study unit. Follow the same procedures for each study unit in the course.

Seeking Assistance

If you have problems with the text or exercise items that you cannot solve, ask your training officer or training NCO for assistance. If they cannot help you, request assistance from your MCI distance learning instructor by calling the Distance Learning Technologies Department's Support Division at DSN 325-7516 or commercial (202) 685-7516, or log on to the MCI home page at www.mci.usmc.mil/feedback/course_developers.

Preparing for the Final Exam

To prepare for your final exam, you must review what you learned in the course. The following suggestions will help make the review interesting and challenging.

- **CHALLENGE YOURSELF.** Try to recall the entire learning sequence without referring to the text. Can you do it? Now look back at the text to see if you have left anything out. This review should be interesting. Undoubtedly, you'll find you were not able to recall everything. But with a little effort, you'll be able to recall a great deal of the information.
 - **USE UNUSED MINUTES.** Use your spare moments to review. Read your notes or a part of a study unit, rework exercise items, review again; you can do many of these things during the unused minutes of every day.
 - **APPLY WHAT YOU HAVE LEARNED.** It is always best to use the skill or knowledge you've learned as soon as possible. If it isn't possible to actually use the skill or knowledge, at least try to imagine a situation in which you would apply this learning. For example make up and solve your own problems. Or, better still, make up and solve problems that use most of the elements of a study unit.
-

Continued on next page

Study Guide, Continued

Preparing for the Final Exam, continued

- **USE THE “SHAKEDOWN CRUISE” TECHNIQUE.** Ask another Marine to lend a hand by asking you questions about the course. Choose a particular study unit and let your buddy “fire away.” This technique can be interesting and challenging for both of you!
 - **MAKE REVIEWS FUN AND BENEFICIAL.** Reviews are good habits that enhance learning. They don’t have to be long and tedious. In fact, some learners find short reviews conducted more often prove more beneficial.
-

Tackling the Final Exam

When you have completed your study of the course material and are confident with the results attained on your study unit exercises, take the sealed envelope marked “**FINAL EXAM**” to your unit training NCO or training officer. Your training NCO or officer will administer the final exam and return the exam the answer sheet to MCI for grading. Before taking your final examination, read the directions on the DP-37 answer sheet carefully.

Completing Your Course

The sooner you complete your course, the sooner you can better yourself by applying what you’ve learned! **HOWEVER**—you do have 2 years from the date of enrollment to complete this course.

Graduating!

As a graduate of this distance training course and as a dedicated Marine, your job performance skills will improve, benefiting you, your unit, and the Marine Corps.

Semper Fidelis!

STUDY UNIT 1

RADIO COMMUNICATIONS

Overview

Introduction The radio is the principal means of communication in today's tactical Marine Corps. It is essential for not only command and control of the battlefield but also for passing routine administrative information. Understanding how radio waves travel or propagate will enhance your ability to establish communications between locations separated by great distances and obstacles.

Scope This study unit discusses the basic building blocks common to all radios and introduces radio waves and their characteristics.

In This Study Unit This study unit contains the following lessons:

Topic	See Page
Radio Sets and Waves	1-3
Carrier Waves and Modulation	1-13

(This page left intentionally blank.)

LESSON 1

RADIO SETS AND WAVES

Overview

Introduction Before you can study the propagation of radio waves, you must learn the origin of these waves, the radio set. The Marine Corps uses many types of radios, ranging from small and manpacked versions to entire systems that must be vehicular transported. To keep it simple, this lesson examines the basic building blocks common to all radios.

Content This lesson discusses the basic parts of a radio and what role each part plays in the overall operation of the radio. Additionally, this lesson introduces you to radio waves and discusses, in depth, the characteristics of radio waves, such as frequency and wavelength.

Learning Objectives At the end of this lesson, you should be able to

- State the purpose of a radio transmitter.
- State the purpose of a radio receiver.
- State what an antenna is used for.
- State the purpose of a power supply.
- Define radio waves.
- State what determines the frequency of a radio wave.
- State the formula used to find the wavelength when the frequency is known.

Continued on next page

Overview, Continued

In This Lesson This lesson contains the following topics:

Topic	See Page
Overview	1-3
Basic Components	1-5
Electro-Magnetic Waves	1-6
Lesson 1 Exercise	1-10

Basic Components

Parts of a Radio

All radios, regardless of size or purpose are comprised of the following parts: a transmitter, a receiver, an antenna, and a power supply.

Radio Transmitter

A transmitter is a device that sends out radio signals. It generates, modulates, and radiates a radio frequency (RF) signal. A transmitter consists of an RF generator, a power amplifier for increasing the level of the signal to the desired level, and a modulator responsible for superimposing the intelligence onto the carrier.

Radio Receiver

The receiver uses highly selective filtering networks to extract the desired electro-magnetic waves from the air. These signals are then amplified to a useable level and the intelligence that was placed upon the carrier in the modulation process is removed in the demodulation process. The intelligence, whether it is voice or data, is then passed to the appropriate portions of the radio for further processing.

Antenna

The antenna has a function in both the transmitting and receiving processes of a radio. In the transmitting process, the antenna provides a means for radiating the RF energy produced by the transmitter and power amplifier into space. In the receiving process, the antenna intercepts or picks up the RF signals radiated by the distant end radio.

Power Supply

Power supplies are devices that provide the voltage necessary to operate electronic equipment. In most radios, the transmitter and receiver draw from the same power supply, with the transmitter consuming the most of the power. Power supplies vary in size and output depending on the characteristics of the radio and can range from a small cell battery to a large diesel engine generator.

Electro-Magnetic Waves

Definition

Radio waves are electro-magnetic energy radiated from an antenna, as shown in the diagram below. These waves travel near the surface of the earth and also radiate skyward at various angles to the surface of the earth. These electro-magnetic waves travel through space at the speed of light, approximately 186,000 miles (300,000 kilometers) per second.

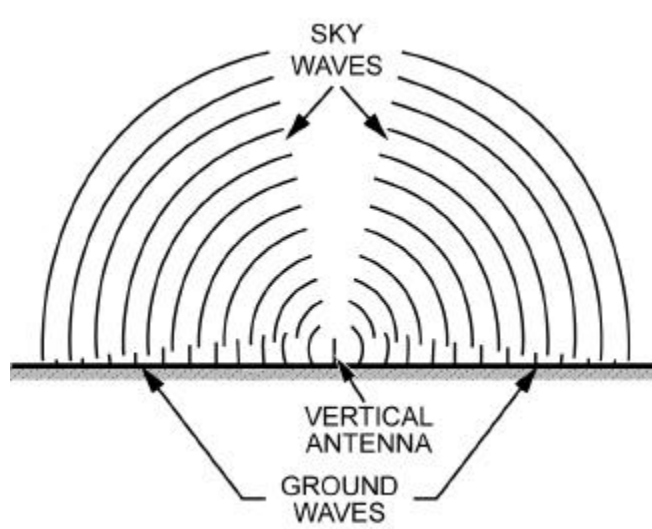

Wavelength

The term *wavelength* refers to the distance a radio wave travels in the period of time required to complete one cycle. Each complete cycle of two alternations of the wave is one wavelength expressed in meters. This wavelength may be measured from the start of one wave to the start of the next wave, as shown in the diagram below or from the crest of one wave to the crest of the next wave. In either case, the distance is the same.

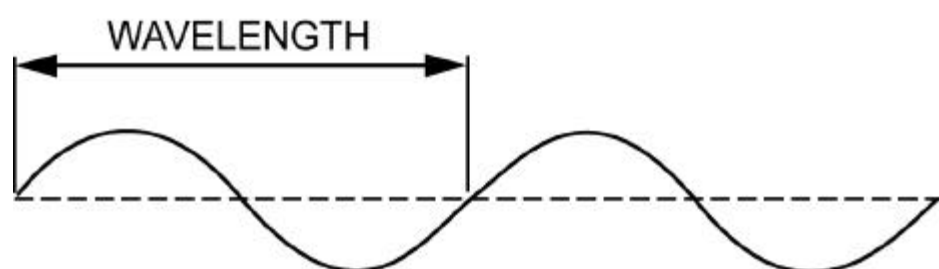

Continued on next page

Electro-Magnetic Waves, Continued

Frequency

The frequency of a radio wave is the number of complete cycles that occur in one second. The longer the time of one cycle, the longer the wavelength and the lower the frequency. The shorter the time of one cycle, the shorter the wavelength and the higher the frequency.

Since the frequency of a radio wave is very great, it is expressed in kilohertz (KHz) or megahertz (MHz). One KHz is equal to 1,000 cycles per second and one MHz is equal to 1,000,000 cycles per second. Compared in the figure below are the wavelengths of a 2 MHz wave and that of a 10 MHz wave.

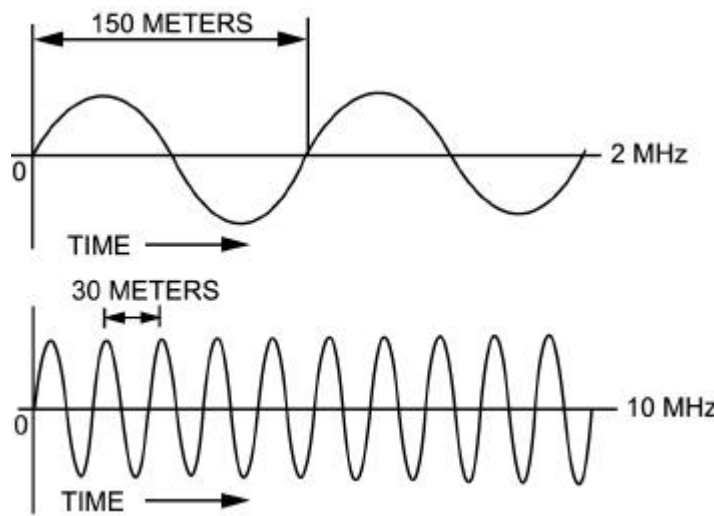

Velocity

Simply stated, velocity is the speed at which a radio wave moves. It is important to note that the velocity of a radio wave is relative to the diameter and conductivity of the material it is traveling through. For instance, radio waves travel faster through copper wire than they do through aluminum.

Continued on next page

Electro-Magnetic Waves, Continued

Velocity Example

For comparison purposes, consider two sound waves, one traveling through free space and one traveling through water. The wave traveling through free space encounters significantly less resistance and therefore can travel farther and faster. At the relatively low speed of sound, these differences are measurable. A million times faster; however, at the relative speed of a radio wave, these speed variations become lost in obscurity. Therefore, for practical purposes, the velocity of a radio wave is considered to be a constant 300 million meters per second, regardless of its frequency or amplitude. To find the wavelength when the frequency is known, divide this constant velocity by the frequency, as shown in the table below. Note that all three equations are equivalent; however, the first uses the frequency in Hertz and the following two use Kilohertz and Megahertz, respectively.

Wavelength (in meters) =	$\frac{300,000,000 \text{ (meters per second)}}{\text{frequency (cycles per second)}}$
	$\frac{300,000}{\text{frequency (KHz)}}$
	$\frac{300}{\text{frequency (MHz)}}$

To find the frequency when the wavelength is known, divide the velocity by the wavelength, as shown in the table below.

Frequency (cycles per second)	$\frac{300,000,000}{\text{wavelength (meters)}}$
Frequency (KHz)	$\frac{300,000}{\text{wavelength (meters)}}$
Frequency (MHz)	$\frac{300}{\text{wavelength (meters)}}$

Continued on next page

Electro-Magnetic Waves, Continued

Frequency Bands of the Radio Spectrum

Most tactical radio sets operate within the 1.5 MHz to 400 MHz portion of the frequency spectrum. For convenience of study and reference, radio frequencies are divided into the groups or bands of frequencies shown below.

Band	Frequency (MHz)
Very Low Frequency (VLF)	Below .03
Low Frequency (LF)	Above .03 to .3
Medium Frequency (MF)	Above .3 to 3.0
High Frequency (HF)	Above 3.0 to 30
Very High Frequency (VHF)	Above 30 to 300
Ultra High Frequency (UHF)	Above 300 to 3,000
Super High Frequency (SHF)	Above 3,000 to 30,000
Extremely High Frequency (EHF)	Above 30,000 to 300,000

Lesson 1 Exercise

Directions Complete items 1 through 7 by performing the action required. Check your answers against those listed at the end of this lesson.

- Item 1** The purpose of a radio transmitter is to generate,
- a. modulate, and radiate a radio frequency (RF) signal.
 - b. demodulate, and radiate a radio frequency (RF) signal.
 - c. modulate, and collect a radio frequency (RF) signal.
 - d. modulate, and amplify a radio frequency (RF) signal.
-

- Item 2** Which is a function of a radio receiver?
- a. Modulates an RF signal
 - b. Radiates an RF signal
 - c. Demodulates an RF signal
 - d. Generates an RF signal
-

- Item 3** In the receiving process, an antenna's purpose is to
- a. radiate RF energy into space.
 - b. demodulate received RF signals.
 - c. intercept RF signals radiated by the distant end radio.
 - d. extract the desired electro-magnetic waves from the air.
-

Item 4 What is the purpose of a power supply?

Continued on next page

Lesson 1 Exercise, Continued

Item 5 Define radio waves.

Item 6 What determines the frequency of a radio wave?

Item 7 Which mathematical calculation is used to find the wavelength when the frequency of a radio wave is known?

- a. Divide frequency by velocity
 - b. Multiply frequency by velocity
 - c. Divide velocity by frequency
 - d. Divide wavelength by velocity
-

Lesson 1 Exercise

Solutions

The table below lists the solutions to the exercise items. If you have any questions about these items, refer to the reference page.

Item Number	Answer	Reference
1	a	1-5
2	c	1-5
3	c	1-5
4	Provides the voltage needed to operate electronic equipment	1-5
5	Electro-magnetic energy radiated from an antenna	1-6
6	The number of complete cycles that occur in one second	1-7
7	c	1-8

Summary

In this lesson, you've learned about the purpose of a radio transmitter, a radio receiver, an antenna, and a power supply. You have also learned about radio waves, their wavelength and velocity, and the different bands of the radio spectrum.

The next lesson shows you how radio waves are used to carry information.

LESSON 2

CARRIER WAVES AND MODULATION

Overview

Introduction When a radio operator speaks into a microphone or a Marine in the field transmits an email, that information is known as intelligence. A radio wave alone carries no intelligence and is known as a carrier wave. This lesson will explain how the intelligence is affixed to the carrier wave on the transmitting end and removed on the receiving end.

Content This lesson introduces you to carrier waves, their function, and discusses how they are modulated.

- Learning Objectives** After completing this lesson, you should be able to
- Define carrier wave.
 - State the process by which information is attached upon a carrier wave.
 - Define amplitude modulation.
 - Define frequency modulation.
 - Define digital modulation.
-

In This Lesson This lesson contains the following topics:

Topic	See Page
Overview	1-13
Carrier Waves	1-14
Amplitude Modulation	1-15
Frequency Modulation	1-16
Digital Modulation	1-18
Lesson 2 Exercise	1-20

Carrier Waves

Explanation

The radio transmitter supplies to the antenna a high frequency alternating current at a fixed level of intensity. This current is called the carrier wave or carrier. The carrier wave alone, as shown below, does not convey information, but acts as a medium for the transmission of information signal. The actual information, which is contained in a signal wave, in the case of analog communications and data stream in the case of digital communications, must be superimposed upon the carrier.

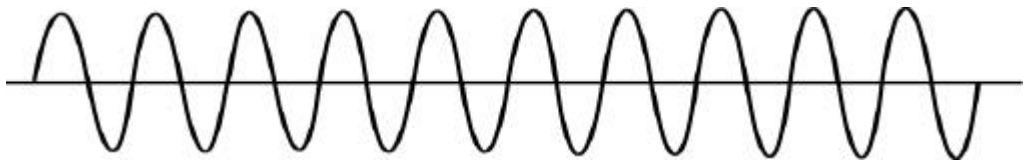

Modulation

The process of superimposing the information upon the carrier is called modulation. This process differs greatly between analog and digital communication systems.

- Analog communications: The modulation process varies or modifies either the frequency or the amplitude of the carrier waveform.
- Digital communications: The carrier wave is shifted to represent a stream of 1's and 0's.

Amplitude modulation (AM), frequency modulation (FM), and digital methods of modulation are all used in military radio communication systems. When audio frequency (AF) signals are superimposed on the radio frequency (RF) carrier, additional RF signals are generated. The additional frequencies are equal to the sum and the difference of the audio frequencies and the radio frequency involved.

Example

Assume that a 1,000 KHz carrier is modulated by a 1 KHz audio tone. Two new radio frequencies are developed: one at 1,001 KHz (the **sum** of 1,000 and 1 KHz) and the other at 999 KHz (the **difference** between 1,000 and 1 KHz). If a complex audio signal is used instead of a single tone, two new frequencies will be set up for each of the audio frequencies involved.

These new frequencies are called sidebands.

Amplitude Modulation

Explanation

Amplitude modulation (AM) is defined as the variation of the RF power output of a transmitter at an audio rate. The RF energy increases and decreases according to the audio (sound) frequencies. Amplitude modulation is the process of varying the power output of a transmitter as illustrated below:

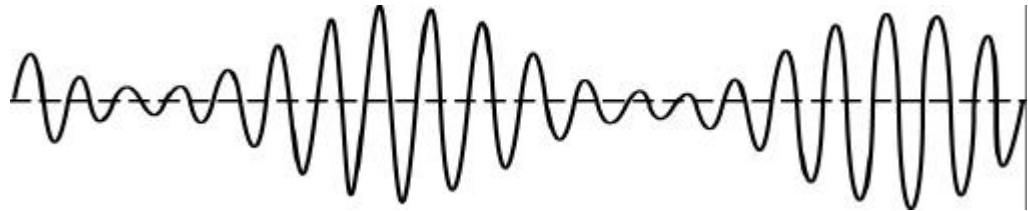

How It Is Modulated

The RF carrier is modulated by a single audio tone in which two additional frequencies are produced. These two new frequencies are equal to the sum and the difference of the two original frequencies. The frequency higher than the carrier frequency is the upper side frequency and the frequency lower than the carrier frequency is the lower side frequency. When the modulating signal is made up of complex tones, as in speech, each individual frequency component of the modulating signal produces its own upper and lower side frequencies. These side frequencies occupy a band of frequencies called sidebands. The sideband that contains the sum of the carrier and modulating frequencies is called the upper sideband. The sideband that contains the difference of the carrier and the modulating frequencies is the lower sideband.

Bandwidth

The space that a carrier and its associated sidebands occupy in the frequency spectrum is called a channel. In amplitude modulation, the width of the channel (bandwidth) is equal to twice the highest modulating frequency.

Example: When a 5,000 KHz carrier is modulated by a band of frequencies ranging from 200 to 5,000 cycles (.2 to 5 KHz), the upper sideband extends from 5,000.2 to 5,005 KHz and the lower sideband extends from 4,999.8 to 4,995 KHz. The entire bandwidth—from 5,005 to 4,995 KHz—is 10 KHz, which is twice the highest modulating frequency (5 KHz).

The intelligence of an amplitude-modulated signal exists solely in the sidebands in which the amplitude varies according to the strength of the modulating signal. Transmitters operating in the medium and high frequency bands of the radio spectrum generally use amplitude modulation.

Frequency Modulation

Explanation

In a frequency-modulated wave, the frequency varies instantaneously about the unmodulated carrier frequency in proportion to the amplitude of the modulating signal. Therefore, when the modulating signal increases in amplitude, the carrier frequency increases instantaneously; when the modulating signal level decreases, the frequency decreases. This fluctuation is illustrated below:



How It Is Modulated

In an FM wave, the amplitude of the modulating signal determines the extent of departure of the instantaneous frequency from the center or rest frequency. Thus, the instantaneous frequency can be made to deviate as much as desired from the carrier frequency by changing the amplitude of the modulating signal. Even though the modulation frequency is only a few kilohertz, this deviation frequency may be as high as several hundred kilohertz. The sideband pairs generated by frequency modulation are not restricted, as in amplitude modulation, to the sum and difference between the highest modulating frequency and the carrier.

Sidebands

The first pair of sidebands in an FM signal is the carrier frequency, plus and minus the modulating frequency. Additional sideband pairs will appear at each multiple of the modulating frequency.

Example: When a carrier of 1 MHz is frequency modulated by an audio signal of 10 KHz, a host of equally spaced sideband pairs will form around the carrier in a rippling fashion. These frequencies will be strongest at 999 KHz and 1,010 KHz, second strongest at 980 KHz and 1,020 KHz, third strongest at 970 KHz and 1,030 KHz, and continuing in the same process.

Bandwidth

The placement of sidebands described above causes an FM wave, consisting of a center frequency and a number of sideband pairs, to occupy a much greater bandwidth than an AM wave. This rippling fashion also forces the amplitude of the modulating signal from the center frequency component to the sideband pairs.

Continued on next page

Frequency Modulation, Continued

The Transmitted Signal

The FM signal leaving the transmitting antenna is constant in amplitude, but varies in frequency according to the modulating signal. The signal, which travels between the transmitting and receiving antennas, encounters natural and manmade noises that cause amplitude variations in the signal. These undesirable amplitude variations are amplified as the signal passes through successive stages of the receiver until the signal reaches the limiter stage.

Limiting and Demodulating

The limiter eliminates amplitude variations and passes the constant-amplitude FM signal on to circuitry designed to detect variations in the frequency of an RF wave. This portion of the receiver, known as the discriminator, transforms the frequency variations of the signal into corresponding voltage amplitude variations. These voltage variations are sent onto demodulating circuits that reproduce the original signal in audio or data devices. This type of modulation is common in the very high frequency band.

Digital Modulation

Explanation

In today's *digital age*, more and more Marine Corps communication equipment generates a digital stream of 1's and 0's instead of the modulating waves that we have discussed up to this point. The previous analog methods of modulation shifted either the amplitude or the frequency of the carrier.

How It Is Modulated

When a digital input is used to modulate the carrier, the phase of the carrier is shifted. This type of modulation is known as phase shift keying (PSK). In the diagram below, the carrier's wave begins at 0, travels in the positive direction, and eventually ends at 0.

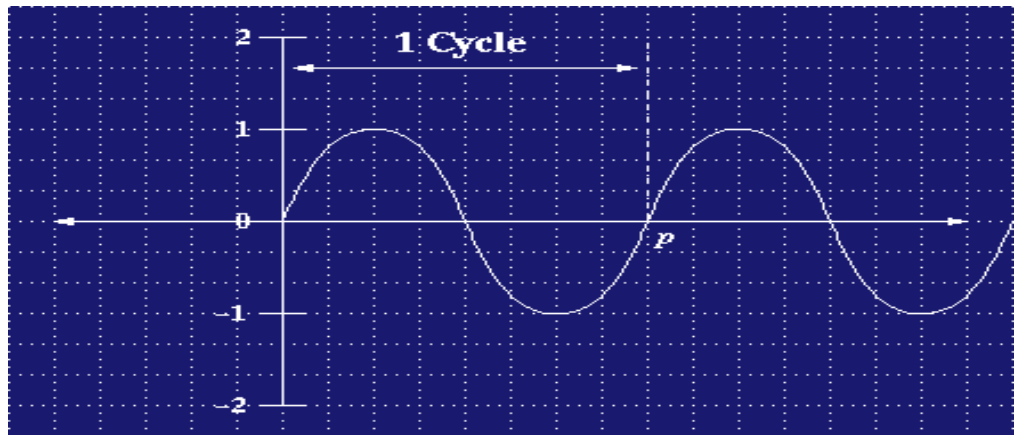

For modulation purposes, this wave could be shifted by 90 degrees, causing the wave to begin at 1, travel in a negative direction, and then finish the cycle at 1. Such a wave in this state is illustrated in the diagram below:

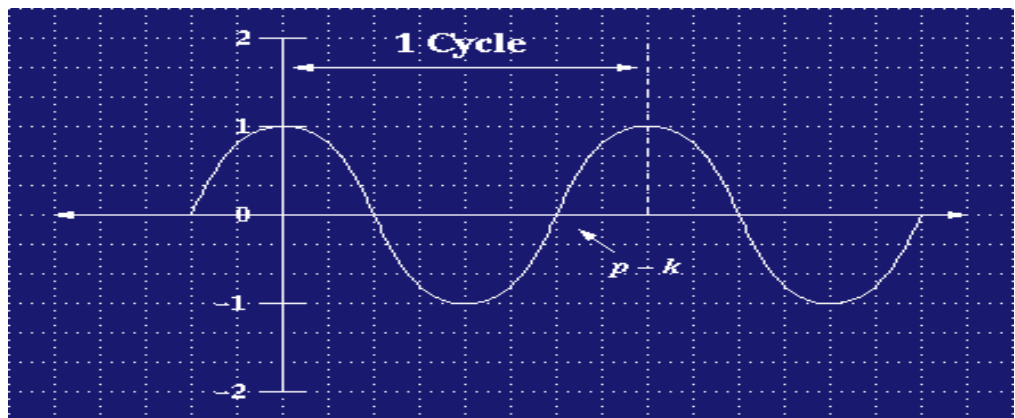

Continued on next page

Digital Modulation, Continued

How It Is Modulated, continued

Furthermore, this wave can be shifted another 90 degrees, to start at the 180 degree point on the graph and yet another 90 degrees, to start at the 270 degree point on the graph. These four distinctly different phases of the wave are assigned individual numerical values that are reconstructed at the receiving station to form the original stream of 1's and 0's. Hypothetical numerical values assigned to each phase of the carrier wave are listed in the table below:

Phase Shift in Degrees	Bit Value
0	00
90	01
180	10
270	11

The Finished Product

Now apply the values above to the digitally modulated carrier shown below and you will see how the original stream of 1's and 0's are recreated.

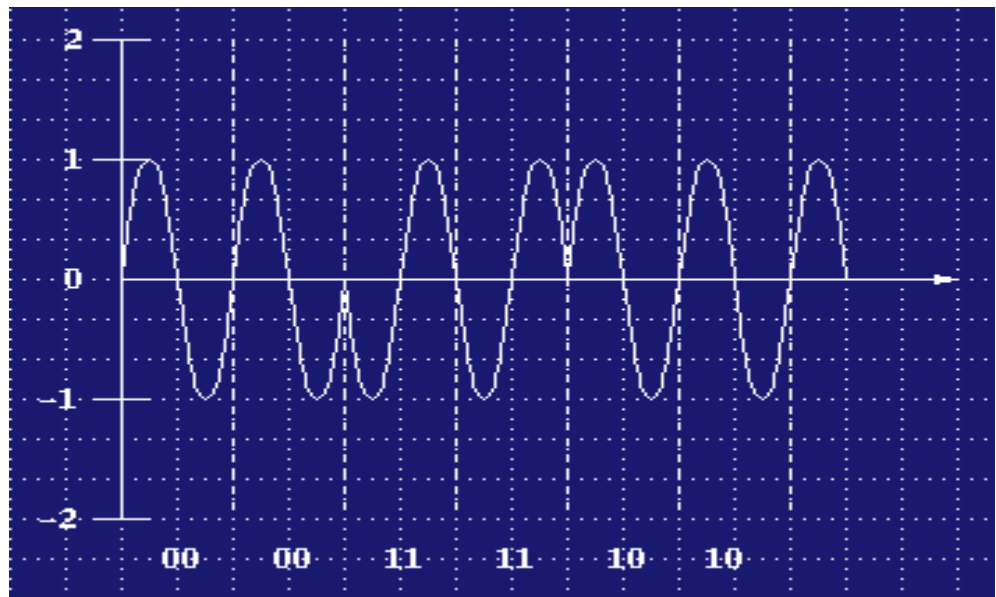

Lesson 2 Exercise

Directions Complete items 1 through 5 by performing the action required. Check your answers against those listed at the end of this lesson.

Item 1 The wave upon which all information is attached or superimposed for transmission defines the

- a. radio wave.
 - b. carrier wave.
 - c. propagated wave.
 - d. electro-magnetic wave.
-

Item 2 When intelligence has been applied to a carrier, the carrier is said to be

- a. amplified.
 - b. demodulated.
 - c. propagated.
 - d. modulated.
-

Item 3 The _____ is the process of varying the RF power output of a transmitter.

Item 4 The _____ is the process of varying the frequency of the carrier wave.

Item 5 The process of shifting the phase of the carrier wave defines

- a. demodulation.
 - b. amplitude modulation.
 - c. frequency modulation.
 - d. phase shift keying.
-

Lesson 2 Exercise

Solutions

The table below lists the solutions to the exercise items. If you have any questions about these items, refer to the reference page.

Item Number	Answer	Reference
1	b	1-14
2	d	1-14
3	amplitude modulation	1-15
4	frequency modulation	1-16
5	d	1-18

Summary

In this study unit, you've learned the basic components of a radio set, how radio waves' electro-magnetic energy is radiated from an antenna, and how analog methods—amplitude, frequency, and digital—modulate a carrier wave.

The next study unit will show you how the atmosphere plays a large part in the propagation of radio waves.

(This page intentionally left blank.)

STUDY UNIT 2

PROPAGATION OF RADIO WAVES

Overview

Introduction Radio communication is not the same at all hours of the day or at all times of the year. Despite the fact that radio waves and the atmosphere above the earth are invisible, the atmosphere plays an important role in radio communications. Solar events, such as sunspots several million miles away, have a direct effect on communications. Since propagation usually takes place within the earth's atmosphere, it is necessary to establish a basic understanding of the air around and above us.

Scope This study unit discusses propagation of radio waves and how the three different layers that make up the earth's atmosphere effect propagation. This study unit will also discuss ground wave, sky wave propagation, skip zones, and how the ionosphere effects long distance sky wave transmissions. Additionally, this study unit will cover the effect fading has on long distance communications and the different propagation paths associated with the different frequency ranges (bands).

In This Study Unit This study unit contains the following lessons:

Topic	See Page
The Atmosphere	2-3
Ground Waves and Sky Waves	2-15
Maximum Usable Frequency (MUF) and Lowest Usable Frequency (LUF)	2-23
Fading	2-29
The Effects of Frequency on Wave Propagation	2-37

(This page left intentionally blank.)

LESSON 1

THE ATMOSPHERE

Overview

Introduction The ionosphere is the most unique layer of the earth's atmosphere. Comprised of many, distinctly different layers, the ionosphere is the region of the atmosphere that we must thoroughly understand to achieve effective communications.

Content This lesson covers the three major layers of the atmosphere, their characteristics, and their location.

Learning Objectives At the end of this lesson, you should be able to

- Describe the atmosphere.
- Name the three layers that make up the atmosphere.
- State the general effect the "D" region has on high frequency radio waves.
- State the region that is ionized at all hours of day and night.
- State what determines the range of long distance radio transmissions.
- Name the two layers of the ionosphere with the highest level of ionization.
- Define critical frequency.

Continued on next page

Overview, Continued

In This Lesson This lesson contains the following topics:

Topic	See Page
Overview	2-3
The Earth's Atmosphere	2-5
The Ionosphere	2-7
Ionosphere Characteristics	2-9
Variations of the Ionosphere	2-10
Lesson 1 Exercise	2-12

The Earth's Atmosphere

Introduction

Wave propagation deals with the properties and the nature of the atmosphere through which radio waves must travel from the transmitting antenna to the receiving antenna. The atmosphere is a gaseous mass that envelops the earth. It is not uniform because it varies with the altitude, temperature, geographic location, time of day or night, season, and year. Knowledge of the composition and properties of the atmosphere aids in the solution of problems that arise in planning radio communication paths and in predicting the reliability of communications. The earth's atmosphere is divided into three regions: the troposphere, the stratosphere, and the ionosphere. Refer to the diagram below for an idea of their location and heights above the earth.

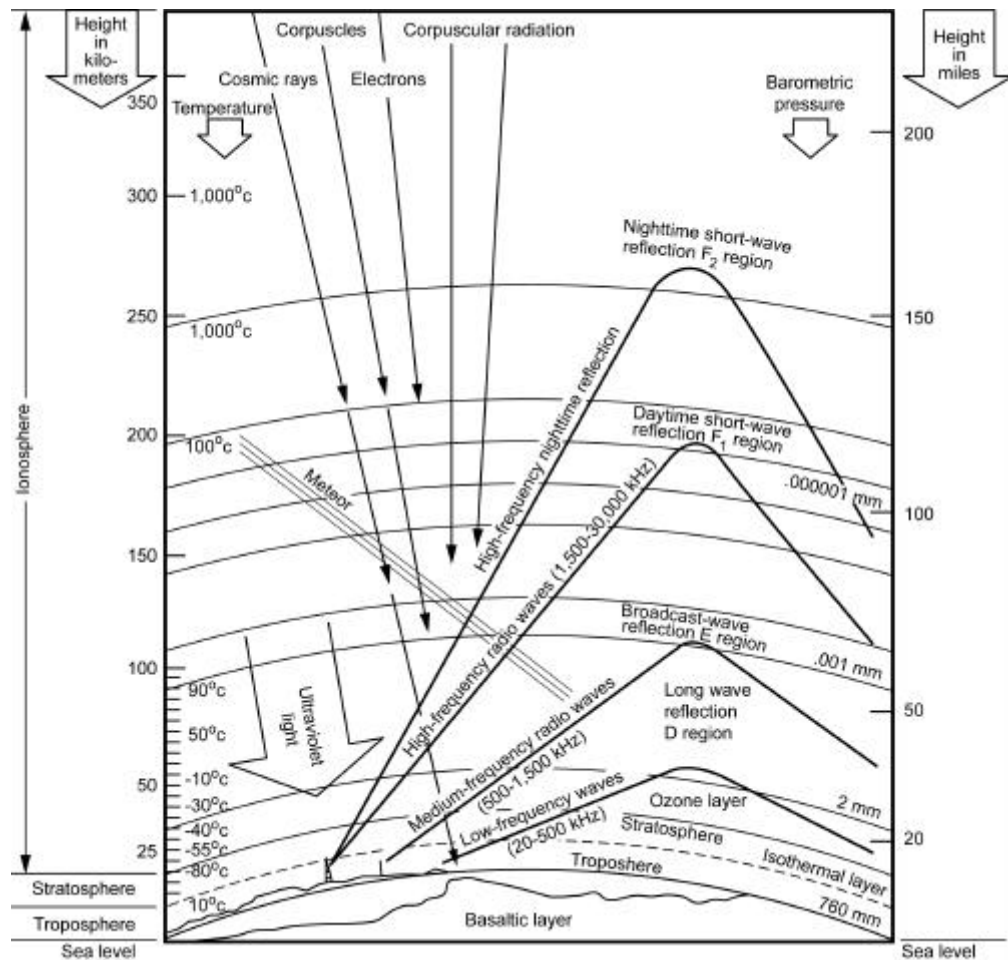

Continued on next page

The Earth's Atmosphere, Continued

Troposphere The troposphere is that portion of the earth's atmosphere extending from the surface of the earth to a height of approximately 6.8 miles. Within the troposphere, the bending of radio waves by refraction causes the radio horizon to exceed the optical horizon. Tropospheric refraction (reflection caused by sudden changes in the characteristics of air in a lower atmosphere) effects the received signal at distances beyond the radio horizon.

Stratosphere The stratosphere is that portion of the earth's atmosphere lying between the troposphere and the ionosphere, from 6.8 miles to 30 miles above the earth. The temperature in this region is nearly constant.

Ionosphere The ionosphere is that portion of the earth's atmosphere above the lowest level at which ionization (splitting of molecules into positive and negative charges or ions) of low pressure gases will effect the transmission of radio waves. It extends from 30 to 250 miles above the earth. The ionosphere is composed of several distinct layers in which ionization occurs at different levels and intensities.

The Ionosphere

Definition

The ionosphere is that portion of the earth's atmosphere containing ionized gases. There are four distinct layers of the ionosphere. In the order of increasing heights and intensities, they are the "D", "E", "F₁", and "F₂" layers. The four layers are present only during the day when the rays of the sun are directed toward that portion of the atmosphere. During the night, the "F₁" and "F₂" layers merge into a single "F" layer and the "D" and "E" layers fade out. The actual number of layers, their heights above the earth, and their relative intensity of internal ionization vary from hour to hour, day to day, month to month, season to season, and year to year. The relative distribution of these layers is shown in the diagram below:

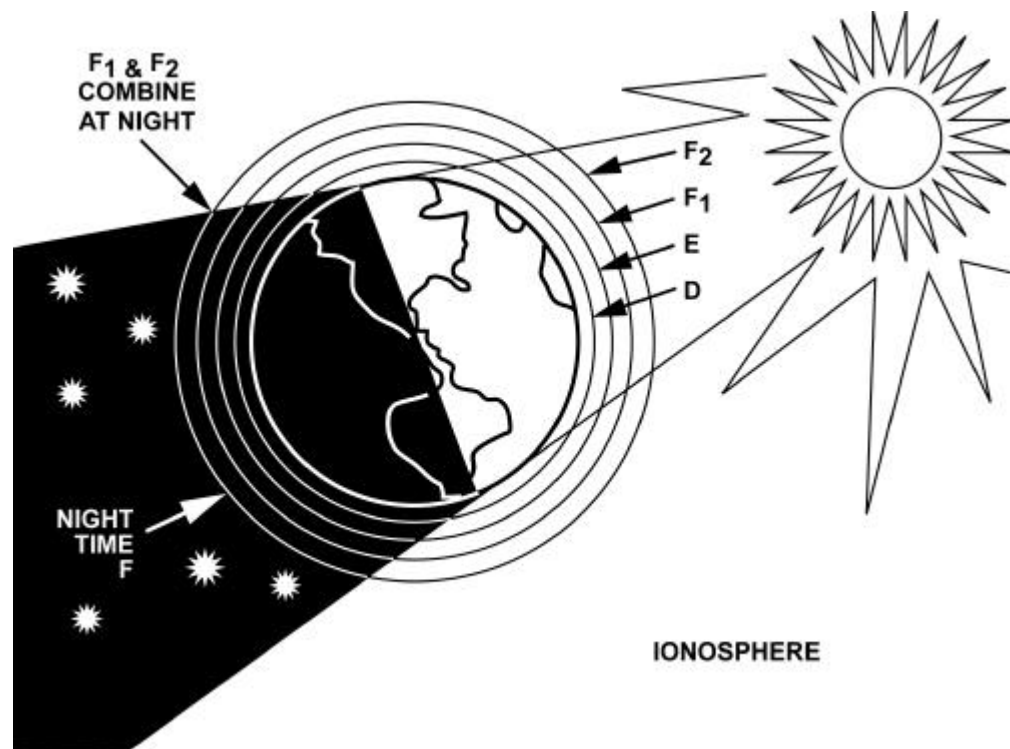

Continued on next page

The Ionosphere, Continued

"D" Region	The "D" region exists only during daylight hours and has little effect in bending the path of high frequency radio waves. The main effect of the "D" region is its ability to attenuate or decrease the intensity of high-frequency waves when the transmission path lies in sunlit regions.
"E" Region	The "E" region is used during the day for high-frequency radio transmission over distances greater than 1,500 miles. The intensity of this layer decreases during the night, rendering it useless for radio transmissions.
"F" Region	The "F" region exists at heights up to 240 miles above the surface of the earth and is ionized at all hours of the day and night. The "F" region is comprised of two well-defined layers during the day and one during the night. At night, the "F" layer lies at a height of about 170 miles and is useful for long-range radio communication (over 1,500 miles).
"F₁" and "F₂" Regions	During the day, air warmed by sunlight causes the "F" region to split into two distinct layers, the "F ₁ " layer and the "F ₂ " layer. The "F ₂ " layer is the most useful of all layers for long-range radio communication, even though the degree of ionization varies appreciably from day to day as compared with other layers.

Ionosphere Characteristics

Critical Frequency

Primarily the ionization density of each ionospheric layer determines the range of long-distance radio transmission. The higher the frequency, the smaller the radio waves, and a greater density of ionization is required to refract the waves back to earth. The upper ("E" and "F") layers refract the higher frequencies because they are the most highly ionized. The "D" layer, which is the least ionized, does not refract frequencies above approximately 500 KHz. Thus, at any given time and for each ionized layer, there is an upper frequency limit at which waves sent vertically upward are reflected directly back to earth. This limit is called the critical frequency. Waves that are directed vertically at frequencies higher than the critical frequency pass through the ionized layer out into space. All waves directed to the ionosphere at frequencies lower than the critical frequency are refracted back to the earth.

Critical Angle

Radio waves used in communication generally are directed to the ionosphere at some oblique angle are called the angle of incidence. Waves at frequencies above the critical frequency can be returned, if propagated at angles of incidence lower than the critical angle. At the critical angle and any angle larger than the critical angle, the wave will pass through the ionosphere if the frequency is higher than the critical frequency. As the angle becomes smaller, an angle is reached at which the wave is bent back to the earth by refraction. The distance between the transmitting antenna and the point at which the wave first returns is called the skip distance.

Variations of the Ionosphere

Definition The movements of the earth around the sun and changes in the sun's activity contribute to ionospheric variations. There are two main classifications of these variations:

- Regular variations: predictable behavior of the sun
 - Irregular variations: abnormal behavior of the sun
-

Regular Variations The regular variations are divided into four classes:

Class	Predictable Behavior
Daily	The rotation of the earth
Seasonal	The north and south progression of the sun
27-Day	The rotation of the sun on its axis
11-Year	The average cycle of sunspot activity

Irregular Variations The transient or momentary ionospheric variations, though unpredictable, have important effects on radio propagation. Some of the major effects are:

- Sporadic E
 - Sudden ionospheric disturbance
 - Ionosphere storms
 - Nuclear detonations
-

Sporadic E When it is excessively ionized, the "E" layer often completely blanks out reflections from the higher layers. This effect may occur during the day or night.

Continued on next page

Variations of the Ionosphere, Continued

Sudden Ionospheric Disturbance

Sudden ionospheric disturbances (SID) are ionization abnormalities of the "D" layer. The most common causes of these disturbances are solar anomalies, such as sunspots or solar flares.

Ionosphere Storms

These storms may last from several hours to several days, and usually extend over the entire earth. During these storms, sky wave transmission above approximately 1.5 MHz shows low intensity and is subject to a type of rapid blasting and fading, known as flutter fading.

Sunspots

Sunspots are caused by magnetic storms on the surface of the sun and can last for weeks. Sunspots that disappear from view behind the sun will often predictably reappear two weeks later as that portion of the sun comes back into view. Sunspots generally follow an 11-year cycle, but can vary daily. Sunspots cause an increase in ionization that will allow the "E" and "F" layers to refract higher frequencies while causing more absorption by the "D" layer.

Solar Flares

Solar flares are large, sudden releases of energy on the sun, which can last from a few minutes to several hours. Usually occurring near sunspots, they can have energy outputs equivalent to the explosion of a billion H-bombs. Solar flares have both immediate and delayed effects on HF communications. The immediate effect is a large increase of solar noise and the start of a SID. These effects, like their originators, can last from a few minutes to several hours. The delayed effects can occur from 30 minutes to 72 hours after the solar flare, and include polar cap absorption and ionospheric storms.

In either case, the result is total absorption of all frequencies above 1 MHz, causing receivers to go dead.

Nuclear Effects

The physical properties of the ionosphere can also be greatly altered during a nuclear exchange. Intense dust clouds formed by surface bursts would cause the "D" layer to become highly ionized from gamma ray radiation caused by low altitude air defense bursts (10 to 35 miles). Bursts, especially those at high altitude (greater than 250 miles) would damage unshielded radio equipment through an effect known as electromagnetic pulse (EMP). Ground wave communications between surviving equipment would be hindered in the direction of surface bursts due to the great amount of dirt in the air and/or the changes in electrical properties of the earth.

Lesson 1 Exercise

Directions Complete items 1 through 7 by performing the action required. Check your answers against those listed at the end of this lesson.

Item 1 The _____ defines atmosphere.

Item 2 The _____, _____, and _____ regions make up the earth's atmosphere.

Item 3 The "D" region of the ionosphere has little effect on which type of radio waves?

- a. Sky waves
 - b. Skip waves
 - c. Low frequency
 - d. High frequency
-

Item 4 The "F" region of the ionosphere is

- a. present only during daylight hours.
 - b. ionized at all hours of day and night.
 - c. comprised of three separate layers.
 - d. rendered useless during the night.
-

Item 5 The range of long distance radio transmissions is determined by the _____ of each ionospheric layer.

- a. height
 - b. location
 - c. temperature
 - d. ionization density
-

Continued on next page

Lesson 1 Exercise, Continued

Item 6

Name the two layers of the ionosphere with the highest level of ionization.

Item 7

Define critical frequency.

Lesson 1 Exercise

Solutions

The table below lists the solutions to the exercise items. If you have any questions about these items, refer to the reference page.

Item Number	Answer	Reference
1	gaseous mass that envelops the earth	2-5
2	troposphere--stratosphere--ionosphere	2-5
3	d	2-8
4	b	2-8
5	d	2-9
6	The upper ("E" and "F") layers	2-9
7	The highest frequency at which waves sent vertically upward are reflected directly back to earth.	2-9

Summary

In this lesson, you've learned about the different layers that compose the earth's atmosphere, as well as the different layers of the ionosphere and their characteristics.

In the next lesson, you will learn about ground waves and sky waves.

LESSON 2

GROUND WAVES AND SKY WAVES

Overview

Introduction Most people assume that radio waves simply travel through the air and that the paths they take to reach their final destination are irrelevant. In the study of radio wave propagation, it is important to realize that radio waves travel by ground modes as well as sky modes. Additionally, it is important to understand that within these two, distinctly different classes, there are several other sub-classes.

Content The lesson discusses how radio waves react when they encounter the surface of the earth and the different parts of the earth's atmosphere.

- Learning Objectives** At the end of this lesson, you should be able to
- Define ground wave propagation.
 - Name the three components of a ground wave.
 - State what sky wave propagation depends upon.
 - Define skip zone.
-

In This Lesson This lesson contains the following topics:

Topic	See Page
Overview	2-15
Ground Wave Propagation	2-16
Sky Wave Propagation	2-17
Lesson 2 Exercise	2-20

Ground Wave Propagation

Definition Ground wave propagation refers to radio transmissions that do not utilize waves that have been refracted from the ionosphere. The field intensity of ground waves depends on the transmitter power, the characteristics of the transmitting antenna, and the frequency of the waves. Additionally, the diffraction of the waves around the curvature of the earth, the conductivity and dielectric constant of the local terrain, the nature of the transmission path, and local weather conditions also effect the intensity of ground waves. The ground wave is comprised of three distinctly different components: the direct wave, the ground-reflected wave, and the surface wave. The three components are identified in the diagram at the bottom of this page.

Direct Wave The direct wave is that component of the entire wave front that travels directly from the transmitting antenna to the receiving antenna. This component is limited to the line-of-sight distance between the transmitting and receiving antennas, plus a small, additional distance caused by the curvature of the earth. Increasing the height of the transmitting antenna or the receiving antenna (or both) can extend this distance.

Ground-Reflected Wave The ground-reflected wave is the portion of the radiated wave that reaches the receiving antenna after being reflected from the surface of the earth. When both the transmitting and receiving antennas are on or close to the ground, the direct and ground-reflected components of the ground wave tend to cancel each other out.

Surface Wave The surface wave, which follows the curvature of the earth, is the component of the ground wave that is effected by the conductivity and dielectric constant of the earth.

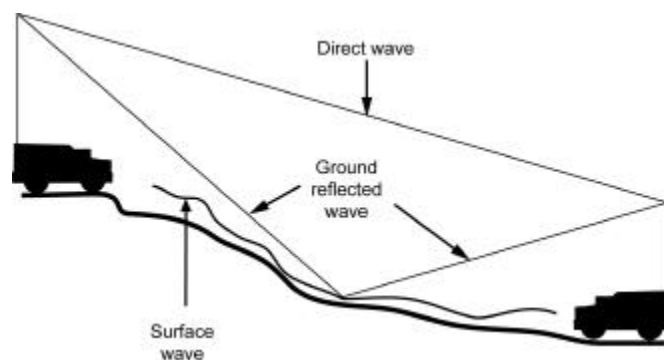

Sky Wave Propagation

Sky Wave Transmission Paths

Sky wave propagation refers to those types of radio transmissions that depend on the ionosphere to provide signal paths between transmitters and receivers. Sky wave transmissions are by far the most important method for long distance radio communications. The various sky wave transmission paths are identified in the diagram below:

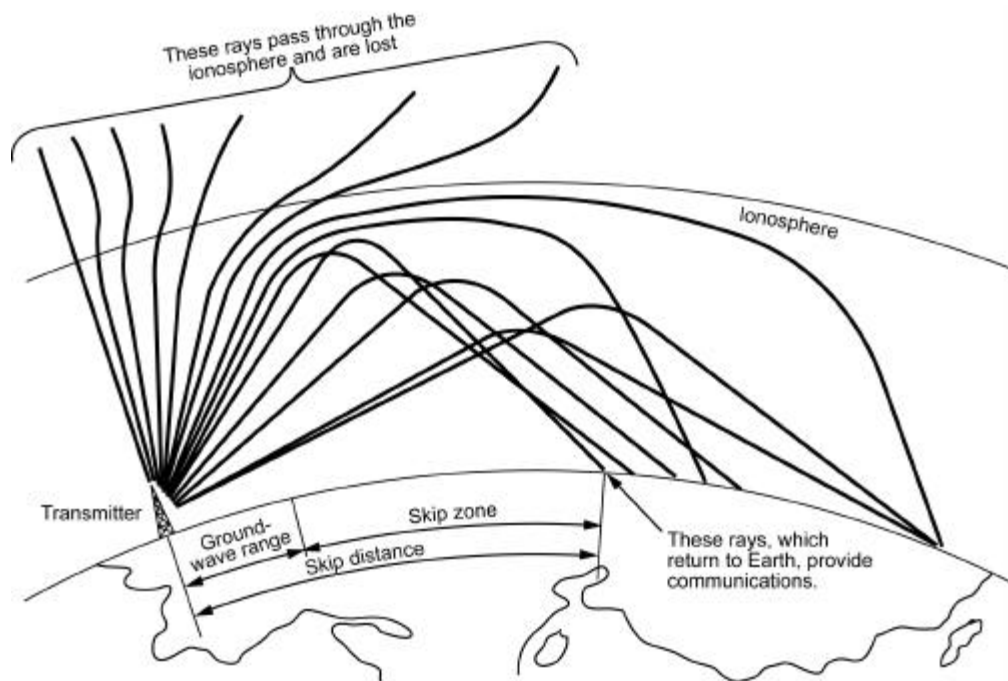

Continued on next page

Sky Wave Propagation, Continued

Sky Wave Modes

The area where the wave returns to the earth depends on the height of the ionized layer and the amount of bending the wave encounters while traversing the layer. This bending is a function of the frequency of the wave as compared to the ion density of the layer. Upon return to the earth's surface, part of the energy enters the earth to be rapidly dissipated, but part is reflected back into the ionosphere where it may reflect downward again at a still greater distance from the transmitter. This means of traveling in hops, bouncing between the ionosphere and the surface of the earth, is known as multi-hop transmission and enables transmissions to be received at long distances from the transmitter. The diagram below illustrates this means of travel for paths involving one, two, or three reflections from the ionosphere (single, double, and triple hop modes or paths).

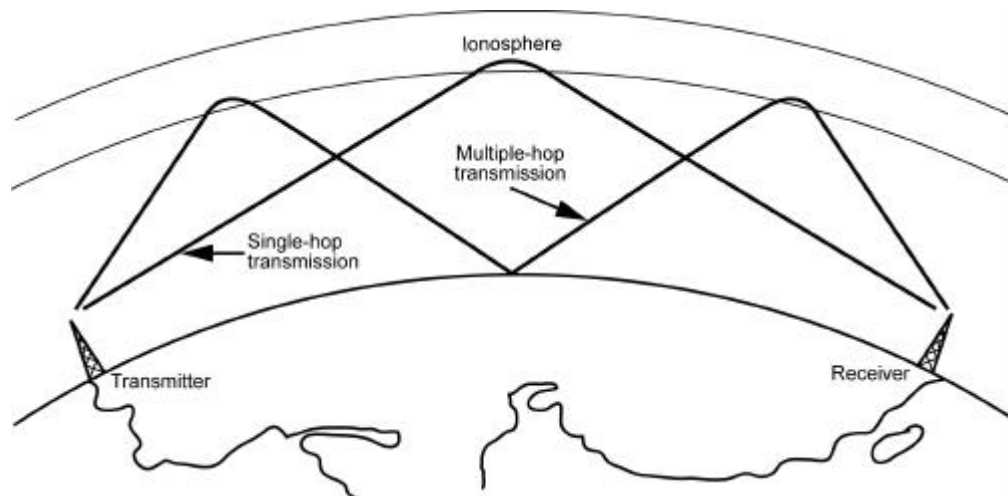

Continued on next page

Sky Wave Propagation, Continued

Skip Zone

The skip zone is that area where no usable signal can be received from a given transmitter operating at a given frequency. This area is bounded by the outer edge of the usable ground-wave propagation and the point nearest the antenna at which the closest sky wave returns to earth. The greater the distance between those two points, the larger the skip zone. Refer to the diagram below for the skip zone and its relation to the ground wave. If the ground wave extends to the point where skip waves begin, there is no skip zone. In this case, both the sky wave and the ground wave may arrive at the antenna with nearly the same field intensity, but at randomly different phases. When this occurs, the sky wave component alternately reinforces and cancels the ground wave component, causing blasting (during reinforcement) and fading (during cancellation) of the signal.

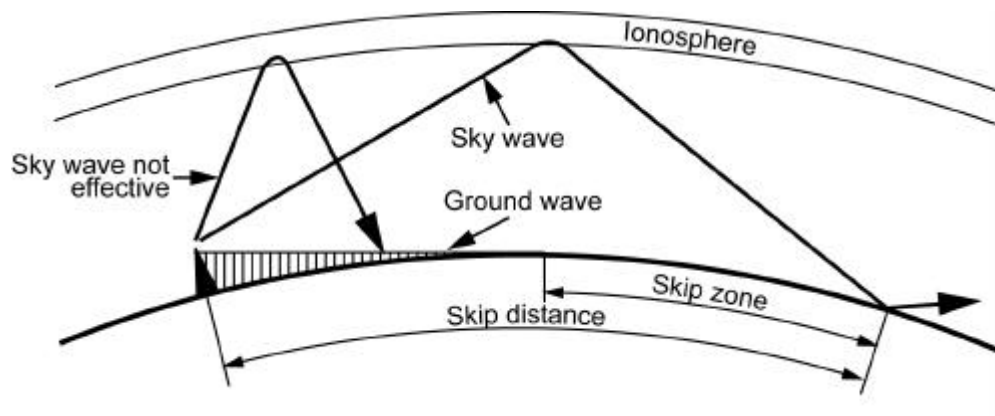

Lesson 2 Exercise

Directions Complete items 1 through 4 by performing the action required. Check your answers against those listed at the end of this lesson.

Item 1 Define ground wave propagation.

Item 2 What are the three components of the ground wave?

- a. Ground wave, sky wave, and skip wave
 - b. Direct wave, ground refracted wave, and skip wave
 - c. Direct wave, ground reflected wave, and surface wave
 - d. Direct wave, ground wave, and sky wave
-

Item 3 Signal paths between the transmitter and receiver in sky wave propagation are provided by the

- a. troposphere.
 - b. ionosphere.
 - c. atmosphere.
 - d. stratosphere.
-

Item 4 Define the skip zone.

Lesson 2 Exercise

Solutions

The table below lists the solutions to the exercise items. If you have any questions about these items, refer to the reference page.

Item Number	Answer	Reference
1	Radio transmissions that do not make use of waves that have been refracted from the ionosphere.	2-16
2	c	2-16
3	b	2-17
4	An area where no usable signal can be received from a given transmitter operating at a given frequency	2-19

Summary

In this lesson, you've learned about ground waves and sky waves.

In the next lesson, you will learn about the maximum usable frequency (MUF) and the lowest usable frequency (LUF).

(This page is intentionally left blank.)

LESSON 3

MAXIMUM USABLE FREQUENCY (MUF) AND LOWEST USABLE FREQUENCIES (LUF)

Overview

Introduction From the previous lessons, it is apparent that the frequency of a radio wave plays a large part in how well the sky wave propagates. In some cases, however, if the frequency of the wave is too high or too low, that wave will not propagate at all. Knowing the frequency limits will aid in frequency selection and make sure communications are effective.

Content This lesson discusses the employment of previously discussed principles to determine which frequencies are best suited for communications.

Learning Objectives At the end of this lesson, you should be able to

- Define maximum usable frequency (MUF).
 - Describe what would happen to frequencies greater than the MUF.
 - Define lowest usable frequency (LUF).
-

In This Lesson This lesson contains the following topics:

Topic	See Page
Overview	2-23
Maximum Usable Frequency (MUF)	2-24
Lowest Usable Frequency (LUF)	2-26
Lesson 3 Exercise	2-27

Maximum Usable Frequency (MUF)

Definition

An important concept associated with sky wave propagation is called the maximum usable frequency (MUF). The MUF is the highest frequency at which a radio wave will reflect from an ionospheric layer for a given elevation or propagation path. Frequencies higher than the MUF will penetrate the layer and escape into space. The diagram below depicts a chart used to determine specific frequencies and their usefulness depending on the time of day.

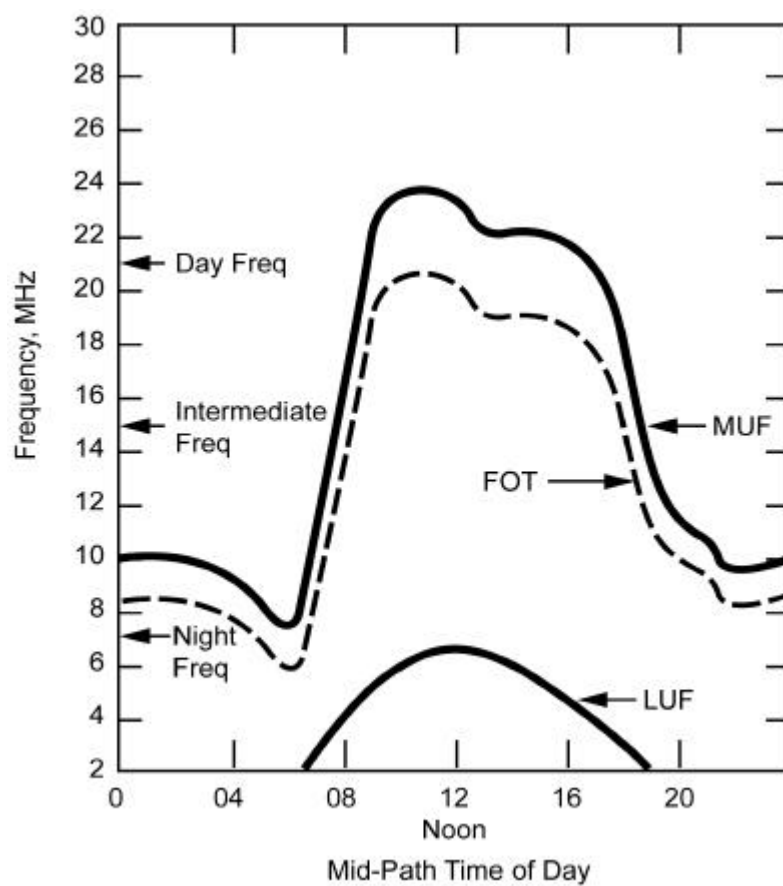

Continued on next page

Maximum Usable Frequency (MUF), Continued

Predictions

It is important at this point to discuss propagation predictions and their statistical nature. The science of predicting ionospheric conditions and selecting frequencies to use for a given path is well developed, but subject to the same accuracy problems as prediction of the local weather. It is impossible to predict with

- Absolute accuracy the best choice of frequency to use for a given propagation path.
- Reasonable accuracy what the MUF will be for a given communication path at a particular time of day.

These predictions are usually based on a statistical reliability of 50 percent.

Example

Assume the MUF for a certain propagation path is predicted to be 12 MHz during the time period of 1200 to 1500 hours for the month of November. This actually means the MUF will be lower than 12 MHz 15 days of the month and higher than 12 MHz the other 15 days of the month. The median MUF for the entire month will be 12 MHz. It also means that on a given day when the MUF is actually 12 MHz, frequencies slightly higher than 12 MHz may be used with greatly reduced reliability.

Frequency Selection

When there is a choice of frequencies to use, it is always best to use a higher frequency. This is especially true when communicating over distances greater than 650 miles. This reduces absorption from any lower layer and minimizes multi-path fading. However, it is generally undesirable to operate at or near the MUF since this frequency is reflected only 50 percent of the time. To allow for day-to-day changes in the MUF and the critical frequency, it is customary to use a frequency that is about 85 percent of the MUF. This lower frequency is known as the frequency of optimum transmission (FOT). It is based on the statistical fact that the FOT lies below the daily variations of the actual MUF about 90 percent of the time. It is not always the frequency for minimum path loss or for minimum fading, and there are times when a frequency 10 percent lower or higher than the FOT will be more reliable. Based on statistics, the FOT represents the best choice for a given path length, time of day, season, and sunspot number.

Lowest Usable Frequency (LUF)

Definition

As the frequency for transmission over any given sky wave path is increased, a value will be reached at which the radio signal just overrides the level of atmospheric and other radio noises. This is called the lowest usable frequency (LUF) because frequencies lower than the LUF are too weak for useful communications. For a given transmitter power as the operating frequency is decreased, the average signal level at the receiver will decrease due to increased ionospheric absorption. The average level of natural atmospheric noise (lightning discharge) and manmade noise (electrical equipment) existing in the vicinity of the receiver increases at lower frequencies. Thus, if the frequency of transmission is reduced much below the critical frequency, the received signal strength decreases while the received noise increases until finally the signal is generally unusable.

Frequency Selection

The LUF depends upon the power of the transmitter, path loss, total noise level at the receiving location, receiving antenna gain and directivity, and noise generated within the receiver itself. Because ionospheric absorption is highest when the "D" layer reaches its peak, the LUF generally peaks around noon. A frequency for day use must be chosen sufficiently above the LUF to ensure a reliable signal-to-noise ratio.

Lesson 3 Exercise

Directions Complete items 1 through 3 by performing the action required. Check your answers against those listed at the end of this lesson.

Item 1 Define maximum usable frequency (MUF).

Item 2 Waves of frequencies higher than that of the MUF will

- a. encounter high levels of atmospheric noise.
- b. be most useful for daytime communications.
- c. penetrate the ionosphere and escape into space.
- d. be reflected by the "F" region of the ionosphere.

Item 3 Define lowest usable frequency (LUF).

Lesson 3 Exercise

Solutions

The table below lists the solutions to the exercise items. If you have any questions about these items, refer to the reference page.

Item Number	Answer	Reference
1	The highest frequency at which a radio wave will reflect from an ionospheric layer for a given elevation or propagation path.	2-24
2	c	2-24
3	The frequency at which the radio signal just overrides the level of atmospheric and other radio noises.	2-26

Summary

In this lesson, you've learned about the maximum usable frequency (MUF) and the lowest usable frequency (LUF), and how these two principles can aid in selecting the proper frequencies to enhance your ability to communicate.

In the next lesson, you will learn about a common obstruction to effective communications known as fading.

LESSON 4

FADING

Overview

Introduction To this point, you have studied the modulated carrier wave, its origin, the various paths the wave can take en route to the receiving station, and the layers of the atmosphere the wave will encounter on its way to the receiving end. Unfortunately, understanding and employing this knowledge is not enough to ensure good communications. Many well-planned communications exercises are plagued by a phenomenon known as fading.

Content This lesson discusses fading and addresses the causes of this phenomenon.

Learning Objectives At the end of this lesson, you should be able to

- Define fading.
- Name the four types of fading.

In This Lesson This lesson contains the following topics:

Topic	See Page
Overview	2-29
Fading Loss	2-30
Types of Fading	2-31
Lesson 4 Exercise	2-34

Fading Loss

Definition

When a radio signal is received over a long distance path, a periodic increase and decrease of received signal strength may result. This phenomenon is most common in the high frequency range. Most modern radios have internal circuitry that eliminates the "blasting" caused by increased signal strength, so this lesson will concentrate on the "fading" caused by decreased signal strength.

Cause and Prevention

The precise origin of fading is seldom understood. There is little common knowledge of what precautions can be taken to reduce or eliminate the troublesome effects of fading. Suggested methods for reducing fading are

- Increase transmitter power and antenna gain
- Use two or more receiving antennas spaced some distance apart with both feeding into the same receiver (space diversity reception)
- Select the proper frequency
- Know the capabilities and limitations of the transmitting and receiving equipment

Fading associated with sky wave paths is the greatest single detriment to reliable communications.

Types of Fading

Four Classes

The many types of fading can be categorized into four principal classes:

- Interference
- Polarization
- Absorption
- Skip

Most cases of rapid fading are caused by a combination of the first two types while the latter two types normally cause gradual fading.

Interference Fading

Interference fading is caused by phase interference of two or more waves from the same source arriving at the receiver over slightly different paths. If the paths are of different lengths and their relative lengths vary for some reason, such as fluctuations in the height of the ionosphere layers, the relative phases of the waves arriving over the different paths vary with time, causing alternate reinforcement and cancellation of the field intensity. This concept is illustrated in the diagram below. Because of irregularities in the ionosphere, one downcoming sky wave is really the summation of a great number of waves of small intensity and of random relative phases, and thus the resultant field intensity can vary greatly.

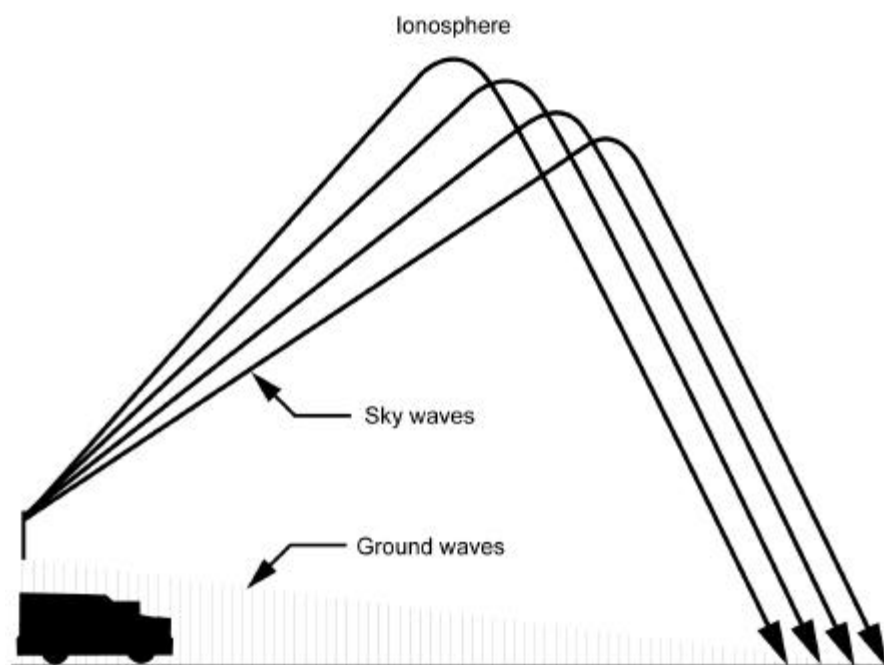

Continued on next page

Types of Fading, Continued

Polarization Fading

Additional variation in the field intensity effecting the receiving antenna occurs when the polarization of the downcoming wave changes in relation to the polarization of the receiving antenna. This variation is called polarization fading. The polarization of the downcoming sky wave is changing constantly. This is due mainly to the combination of the two oppositely polarized components—the ordinary and the extraordinary wave—at random amplitudes and phases.

The polarization of the downcoming sky wave is generally elliptical. Elliptical polarization means that as the wave travels along the signal path, the electric and magnetic fields remain at right angles to each other and to the direction of propagation, rotating about the signal path in a corkscrew fashion. This results in random and constantly changing values of the amplitude and orientation of the electric field with respect to the receiving antenna. The state of polarization of sky waves varies more rapidly than the higher frequency, which accounts in part for the rapid fading on the higher frequencies.

Absorption Fading

Absorption fading is caused by short-term variations in the amount of energy lost from the wave because of absorption in the ionosphere. In general, the time period of this type of fading is much longer than that of other types since the ionospheric absorption usually changes slowly. In extreme cases, sudden ionospheric disturbances can account for this type of fading, although it is usually classified as an irregular disturbance rather than fading.

Another example of this type of fading is the reflection and absorption of radio waves by objects close to the receiver, such as when a vehicle is passing under a bridge or near a heavy steel structure and can no longer receive radio signals. Radiation from wires, fences, and steel structures can cause an interference pattern that is relatively fixed in space, and can be detected only by moving the receiving equipment around the radiating structure. Therefore, care must be exercised when selecting communication sites with nearby structures that could produce these effects.

Continued on next page

Types of Fading, Continued

Skip Fading

Skip fading is observed at places near the limit of the skip distance, and is caused by the changing angle of refraction. Near sunrise and sunset when the ionization density of the ionosphere is changing, the MUF for a given transmission path may fluctuate about the actual operation frequency. When the skip distance extends out past the receiving station, the received signal level drops abruptly and then increases just as abruptly when the skip distance moves back in. This may take place many times before conditions reach a steady state.

Lesson 4 Exercise

Directions Complete items 1 and 2 by performing the action required. Check your answer against that listed at the end of this lesson.

Item 1 Define fading.

Item 2 The four types of fading are interference, polarization,

- a. absorption, and switch.
- b. antenna, and skip.
- c. absorption, and skip.
- d. reflection, and skip.

Lesson 4 Exercise

Solutions

The table below lists the solution to the exercise item. If you have any questions about this item, refer to the reference page.

Item Number	Answer	Reference
1	The periodic increase and decrease of received radio signal strength.	2-30
2	c	2-31

Summary

In this lesson, you've learned about fading as well as the most common causes and effects of fading.

In the next lesson, you will learn how to select the appropriate type of propagation for a given frequency.

(This page intentionally left blank.)

LESSON 5

THE EFFECTS OF FREQUENCY ON WAVE PROPAGATION

Overview

Introduction Different frequencies behave differently depending on which methods of propagation are employed. The principles that have been discussed in the previous lessons have shown that some methods of propagation are unsuitable for certain frequencies.

Content Utilizing the principles discussed in the previous lessons, this lesson reveals which methods of propagation work best for which frequency bands.

Learning Objectives At the end of this lesson, you should be able to

- State the types of propagation and which types are best for specific frequency bands.
- State the wave propagation that is extremely useful for communications at the low frequency band.
- State the wave propagation that is extremely useful for communications at the medium frequency band.
- State the wave propagation that is extremely useful for communications at the high frequency band.
- State the only wave propagation path that can be used for communications at the ultra high frequency band.

In This Lesson This lesson contains the following topics:

Topic	See Page
Overview	2-37
Wave Propagation	2-38
Lesson 5 Exercise	2-39

Wave Propagation

Definition The effects of the atmospheric layers on wave propagation—as described in the previous lessons—are complicated further by variations in frequency of the transmitted wave. The propagation principles for frequencies at the low end of the frequency spectrum are drastically different than those at the high end of the spectrum. (For ease of identification, frequencies are usually classified in the ranges shown on page 1-7). It is also important to remember that radio waves travel by means of ground waves, sky waves, or a combination of both.

Low Frequency At low frequencies (.03 to .3 MHz), the ground wave is extremely useful for communication over greater distance. The ground wave signals are quite stable and show little seasonal variation.

Medium Frequency In the medium-frequency band (.3 to 3.0 MHz), the range of the ground wave varies from about 15 miles at the low end of the band to about 400 miles at the high end. Sky wave reception is possible during day or night at any of the lower frequencies in this band. At night, the sky wave gives reception at a distance up to 8,000 miles.

High Frequency In the high-frequency band (3.0 to 30 MHz), the range of the ground wave decreases with an increase in frequency and the sky waves are greatly influenced by ionospheric conditions.

Very High Frequency In the very-high-frequency band (30 to 300 MHz), there is no usable ground reflected and no surface wave, only a slight refraction of sky waves by the ionosphere at the lower frequencies. The direct wave provides communication if the transmitting and receiving antennas are elevated sufficiently above the surface of the earth. Transmission over any greater range is unpredictable and will last only for short periods of time because of sporadic conditions in the ionosphere.

Ultra High Frequency In the ultra-high-frequency band (300 to 3,000 MHz), the direct wave must be used for all radio transmissions. Communication is limited to a short distance beyond the horizon. Lack of static and fading in these bands make line-of-sight reception very good. Highly directive antennas can be built into a space to concentrate RF energy into a narrow beam, increasing the signal intensity.

Lesson 5 Exercise

Directions Complete items 1 through 5 by performing the action required. Check your answers against those listed at the end of this lesson.

Item 1 What wave propagation is useful for communications at low frequencies?

- a. Ground wave
 - b. Sky wave
 - c. Direct wave
 - d. Skip wave
-

Item 2 What two types of wave propagation are useful in the medium-frequency band?

(1) _____

(2) _____

Item 3 What two types of wave propagation are available for use in the high-frequency band?

(1) _____

(2) _____

Item 4 What propagation wave or component of a propagation wave provides the best communication in the very-high-frequency band?

- a. Ground wave
 - b. Sky wave
 - c. Surface wave
 - d. Skip wave
-

Continued on next page

Lesson 5 Exercise, Continued

Item 5

Which component of the ground wave provides the best communication in the ultra-high-frequency band?

- a. Sky wave
 - b. Skip wave
 - c. Ground wave
 - d. Direct wave
-

Lesson 5 Exercise

Solutions

The table below lists the solutions to the exercise items. If you have any questions about these items, refer to the reference page.

Item Number	Answer	Reference
1	a	2-38
2	(1) Ground wave (2) Sky wave	2-38
3	(1) Ground wave (2) Sky wave	2-38
4	a	2-38
5	d	2-38

Summary

In this study unit, you've learned about the earth's atmosphere and the three different layers that make up the atmosphere. You know about ground wave and sky wave propagation, skip zones, and how the ionosphere effects long distance sky wave transmissions. Additionally, you are able to recognize the effect fading has on long distance communications and the different propagation paths associated with the different frequency ranges.

In the next study unit, you will learn the general characteristics of antennas, as well as some of the common Marine Corps antennas and different types of field expedient antennas.

(This page intentionally left blank.)

STUDY UNIT 3

ANTENNAS

Overview

Introduction This study unit identifies the functions of an antenna, the components of the radiation field, and antenna polarization. It also discusses the polarization requirements for various frequencies and the advantages afforded by using either vertical or horizontal polarization.

Scope This study unit also discusses the conventional field antennas used by the Marine Corps and seven types of field expedient antennas. It covers various types of transmission lines and standing waves.

In This Study Unit This study unit contains the following lessons:

Topic	See Page
Functions of an Antenna and Antenna Radiation	3-3
Antenna Polarization	3-11
Conventional Antennas	3-21
Field Expedient Antennas	3-33
Transmission Lines	3-47

(This page left intentionally blank.)

LESSON 1

FUNCTIONS OF AN ANTENNA AND ANTENNA RADIATION

Overview

Introduction The study of antennas is essential to gain a complete understanding of radio communication and other electronic systems. In such systems, energy in the form of radio or electro-magnetic waves is generated by electronic equipment and fed to an antenna by means of a transmission line. The antenna radiates this energy at roughly the speed of light. Receiving antennas placed in the path of the traveling wave absorb part of this energy and send it to the receiving equipment by means of a transmission line.

Content This lesson discusses the differences between transmit and receive antennas and shows how these antennas propagate or collect radio waves. This lesson also describes the different fields that are radiated by transmitting antennas.

Learning Objectives At the end of this lesson, you should be able to

- State the function of a transmitting antenna.
- Identify which field is radiated beyond the transmitting antenna.
- Name the two components that make up the radiation field.
- Name the field that is formed from the electric and magnetic components of the radiation field.
- State the purpose of a receiving antenna.

In This Lesson This lesson contains the following topics:

Topic	See Page
Overview	3-3
Functions of an Antenna	3-4
Antenna Radiation	3-6
Lesson 1 Exercise	3-8

Functions of an Antenna

Transmitting

The function of a transmitting antenna is to convert the output power delivered by a radio transmitter into an electro-magnetic field that radiates through space. Therefore, the transmitting antenna converts energy having one form to energy having another form.

Direction of Power

When power is delivered to an antenna, two fields are set up by the fluctuating energy: one is the induction field that associates with the stored energy and the other is the radiation field that moves out into space at nearly the speed of light. At the antenna, the intensities of these fields are high and proportional to the amount of power delivered to the antenna. However, at a short distance from the antenna and beyond, only the radiation field remains.

Components of Electro-magnetic Waves

The radiation field is composed of an electric component and a magnetic component. The electric and magnetic fields (components) radiated from an antenna form the electro-magnetic field; this field is responsible for the transmission of electro-magnetic energy through free space. Thus, the radio wave may be described as a moving electro-magnetic field having velocity in the direction of travel, and with components of electric intensity and magnetic intensity arranged at right angles to each other. This relationship is identified in the diagram below:

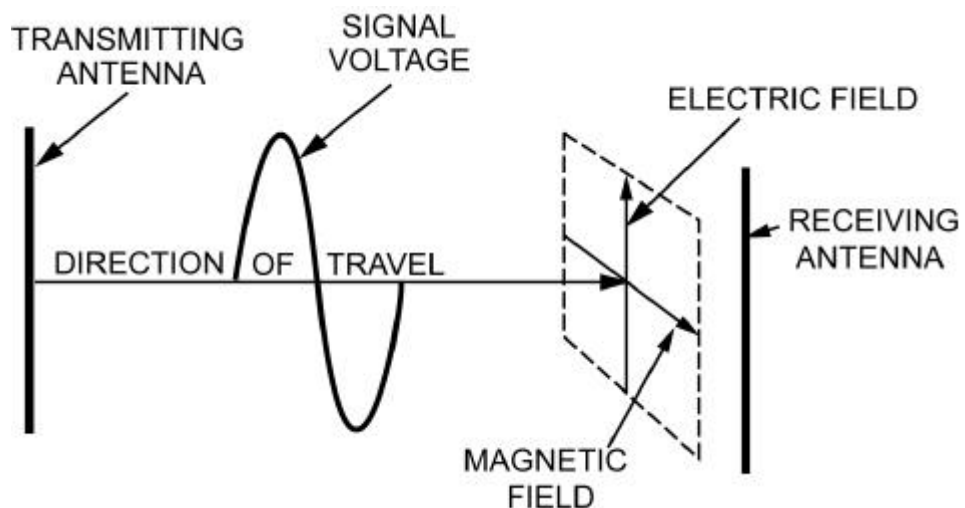

Continued on next page

Functions of an Antenna, Continued

Receiving

The receiving antenna reverses the energy conversion. The function of the receiving antenna is to convert the electro-magnetic field into energy that is delivered to a radio receiver. In transmitting, the antenna operates as the load for the transmitter; in receiving, it operates as the signal source for the receiver.

Antenna Radiation

Patterns

The energy of radio signals radiated by an antenna from an electro-magnetic field having a definite pattern depends on the type of antenna used. This radiation pattern is used to show both range and directional characteristics of an antenna. A vertical antenna theoretically radiates energy equally in all directions. In practice, the pattern is usually distorted by nearby obstructions or terrain features.

Three-Dimensional

The full or solid radiation pattern is a three-dimensional figure that looks somewhat like a doughnut. A three-dimensional depiction of a quarter-wave vertical antenna with the transmitting antenna in the center is shown below:

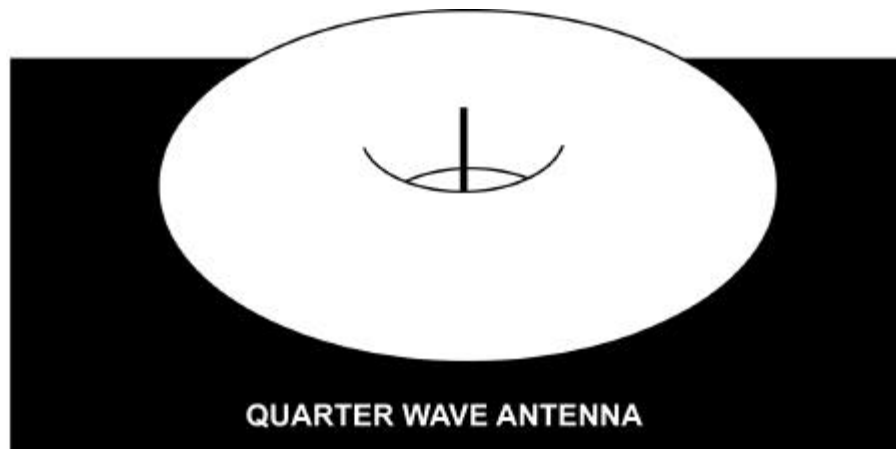

Continued on next page

Antenna Radiation, Continued

Cross Sectional Despite the aesthetic quality of a three-dimensional radiation pattern, the most widely recognized method of illustrating radiation patterns is by plotting the full pattern, showing only one particular plane. This type of pattern is referred to as cross sectional and is shown below.

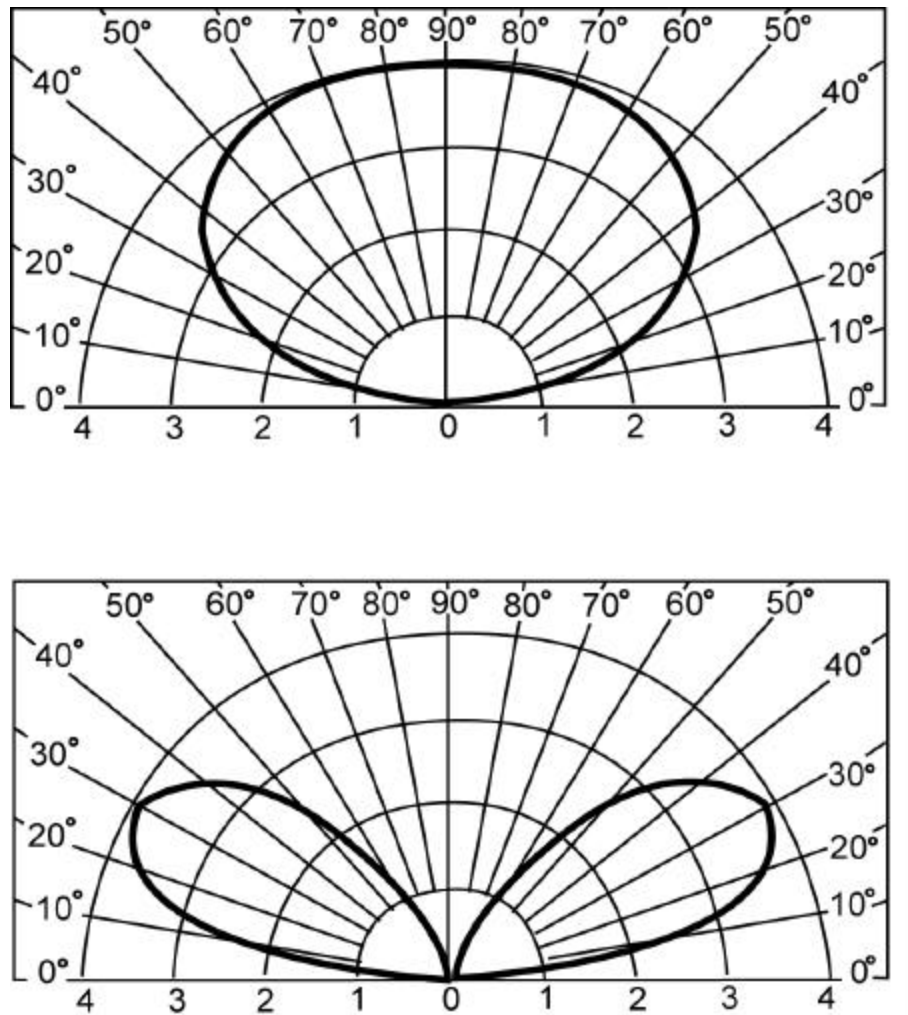

The top radiation pattern is that of a half-wave horizontal antenna one quarter wavelength above the ground and the bottom pattern is that of a half-wave horizontal antenna, one half wavelength above the ground.

Lesson 1 Exercise

Directions Complete items 1 through 5 by performing the action required. Check your answers against those listed at the end of this lesson.

Item 1 The function of a transmitting antenna is to convert the transmitter output power into a(n)

- a. electro-magnetic field.
 - b. induction field.
 - c. magnetic field.
 - d. radiation pattern.
-

Item 2 Which of the two fields set up by fluctuating energy is radiated out into space?

- a. Induction
 - b. Convection
 - c. Radiation
 - d. Electron
-

Item 3 The radiation field is composed of a(n) _____ component and a _____ component.

- a. induction--convection
 - b. electric--magnetic
 - c. induction--magnetic
 - d. induction--radiation
-

Item 4 The electric and magnetic fields (components) radiated from an antenna form the _____ field.

- a. radiation
 - b. magnetic
 - c. electro-magnetic
 - d. induction
-

Continued on next page

Lesson 1 Exercise, Continued

Item 5

What is the purpose of a receiving antenna?

Lesson 1 Exercise

Solutions

The table below lists the solutions to the exercise items. If you have any questions about these items, refer to the reference page.

Item Number	Answer	Reference
1	a	3-4
2	c	3-4
3	b	3-4
4	c	3-4
5	Converts the electro-magnetic field into energy that is delivered to a radio receiver	3-5

Summary

In this lesson, you've learned about the roles of receiving and transmitting antennas, radiation patterns, and the different radiated fields.

In the next lesson, you will learn about polarization.

LESSON 2

ANTENNA POLARIZATION

Overview

Introduction The previous lesson described a radio wave as a moving electro-magnetic field having velocity in the direction of travel, and with components of electric intensity and magnetic intensity arranged at right angles to each other. This lesson expands upon that concept and shows how rotating that electro-magnetic field or polarizing it can enhance communications.

Content This lesson discusses the concept of antenna polarization, the two primary types of propagation, and the advantages and applications of each type.

- Learning Objectives** At the end of this lesson, you should be able to
- State how the polarization of a radiated wave is determined.
 - Name the two types of antenna polarization.
 - Identify the antenna polarization to be used when working with medium and low frequencies.
 - State why it is better to use horizontally polarized antennas at high frequencies.
 - State what type of polarization should be used at very-high and ultra-high frequencies.
-

In This Lesson This lesson contains the following topics:

Topic	See Page
Overview	3-11
Polarization	3-12
Polarization Selection	3-14
Benefits of Vertical Polarization	3-15
Benefits of Horizontal Polarization	3-16
Receiving Antennas	3-17
Lesson 2 Exercise	3-18

Polarization

Definition

Polarization of a radiated wave is determined by the direction of the electric field lines of force. The two types of polarization are vertical and horizontal.

Vertical Polarization

If the electric field lines of force are at right angles to the surface of the earth, the wave is vertically polarized. This concept is illustrated in the diagram below:

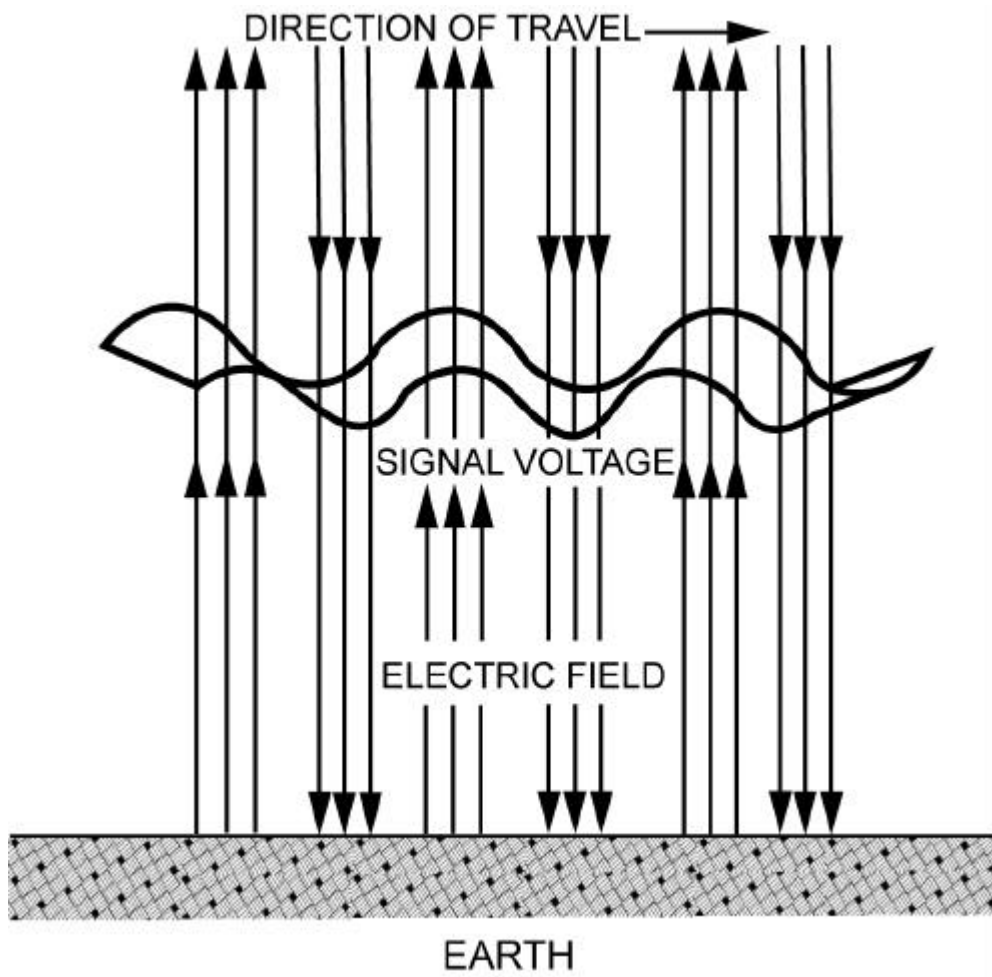

Continued on next page

Polarization, Continued

Horizontal Polarization

If the electric field lines of force are parallel to the surface of the earth, the wave is said to be horizontally polarized as shown in the diagram below:

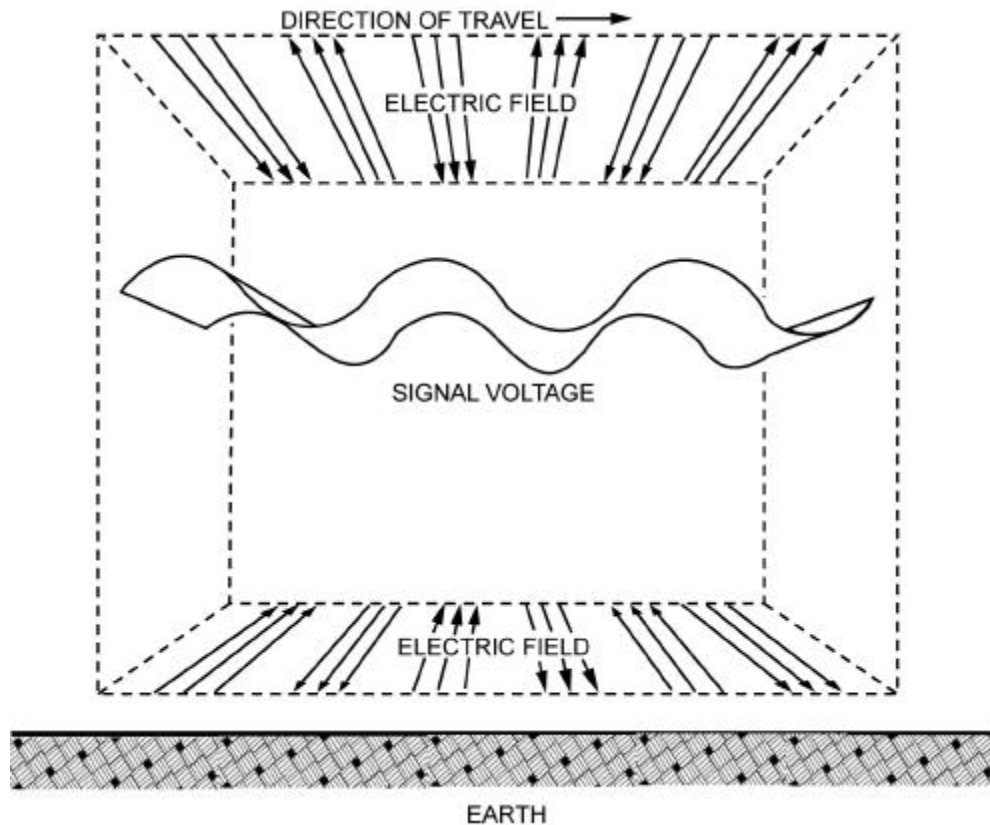

Proper Orientation

A single-wire antenna is used to extract energy from a passing radio wave. Therefore, maximum reception results when the antenna is oriented so that it lies in the same direction as the transmitting antenna, which subsequently orients it to the electric-field component. Thus, a vertical antenna is used for efficient reception of vertically polarized waves and a horizontal antenna is used for the reception of horizontally polarized waves. In some cases, the field rotates as the wave travels through space. Under these conditions, both horizontal and vertical components of the field exist and the wave is said to have elliptical polarization.

Polarization Selection

Medium and Low Frequencies

At medium and low frequencies, ground wave transmission is used extensively. For this reason, it is necessary to use vertical polarization. Vertical lines of force are perpendicular to the ground, and the radio wave can travel a considerable distance along the ground surface with a minimum amount of attenuation (loss). Because the earth acts as a fairly good conductor at low frequencies, horizontal lines of force are shorted out—limiting the useful range of horizontally polarized waves.

High Frequencies

At high frequencies with sky wave transmission, it makes little difference whether horizontal or vertical polarization is used. The sky wave reflected by the ionosphere, arrives at the receiving antenna elliptically polarized. Therefore, the transmitting and receiving antennas can be mounted either horizontally or vertically. Horizontal antennas are preferred because they can be made to radiate effectively at high angles and have inherent directional properties.

Very- and Ultra-High Frequencies

With frequencies in the very-high or ultra-high range, either horizontal or vertical polarization is satisfactory. Since the radio wave travels directly from the transmitting antenna to the receiving antenna, the original polarization produced at the transmitting antenna is maintained throughout the travel of the wave to the receiving antenna. Therefore, if a horizontal half-wave antenna is used for transmitting, a horizontal antenna must be used for receiving. If a vertical half-wave antenna is used for transmitting, a vertical antenna must be used for receiving.

Benefits of Vertical Polarization

Vehicular Applications

Simple, vertical half-wave antennas can be used to provide omni-directional communication that has the ability to communicate with a moving vehicle. When antenna heights are limited to 10 feet or less, as in vehicular installation, vertical polarization provides a stronger received signal at frequencies up to about 50 MHz. From approximately 50 to 100 MHz, there is only a slight improvement over horizontal polarization with antennas of the same height. The difference in signal strength above 1100 MHz is negligible.

Over Water

For transmission over large bodies of water, vertical polarization is decidedly better than horizontal when antennas are below approximately 300 feet at 30 MHz. You would only need 50 feet at 85 MHz and still lower at higher frequencies. Therefore, an ordinary antenna at mast heights, such as 40 feet, vertical polarization is advantageous for frequencies less than about 100 MHz.

Aircraft Interference

Radiation using vertical polarization is less effected by reflections from aircraft flying over the transmission path. With horizontal polarization, such reflections cause variations in the received signal strength. This factor is important in locations where aircraft traffic is heavy.

Broadcast Interference

With vertical polarization, less interference is produced or picked up because of strong VHF and UHF broadcast transmission and reception (television and frequency modulation), all of which use horizontal polarization. This factor is important when an antenna must be located in an urban area having several television and commercial FM broadcast stations.

Benefits of Horizontal Polarization

Bi-Directional A simple horizontal half-wave antenna is bi-directional. This characteristic can help minimize interference from certain directions. Additionally, horizontal antennas are less apt to pick up man-made interference that is polarized vertically.

Heavy Foliage When antennas are located near dense forest, horizontally polarized waves suffer lower losses than vertically polarized waves, especially above about 100 MHz.

Flexibility Small changes in antenna location do not cause large variations in the field intensity of horizontally polarized waves when antennas are located among trees or buildings. When vertical polarization is used, a change of only a few feet in the antenna location may have a considerable effect on the received signal strength. This is the result of interference patterns that produce standing waves in space when spurious reflections from trees or buildings occur.

Since the interference patterns will vary even when the frequency is changed by only a small amount, considerable distortion may occur when complex types of modulation are used, as with television signals or with certain types of pulse-modulation systems. Under these conditions, horizontal polarization is preferred.

Compatibility With Transmission Line When simple half-wave antennas are used, the transmission line (usually vertical) is less effected by a horizontally mounted antenna. Keeping the antenna at right angles to the transmission line and using horizontal polarization keep the line out of the direct field of the antenna. As a result, the radiation pattern and electrical characteristics of the antenna are practically not effected by the presence of the vertical transmission line.

Receiving Antennas

Vertical Antennas

Vertical receiving antennas accept radio signals equally from all horizontal directions, just as vertical transmitting antennas radiate equally in all horizontal directions. Because of this characteristic, other stations operating on the same or adjacent frequencies may interfere with the desired signal and make reception difficult or impossible. However, reception of a desired signal can be improved by using directional antennas.

Horizontal Antennas

Horizontal half-wave antennas accept radio signals from all directions, except signals originating in direct line with the ends of the antenna. When only one signal is causing interference or when several interfering signals are coming from the same direction, interference can be eliminated or reduced by changing the antenna position so that either end of the antenna points directly at the interfering station.

Lesson 2 Exercise

Directions Complete items 1 through 9 by performing the action required. Check your answers against those listed at the end of this lesson.

Item 1 What determines the polarization of a radiated wave?

- a. The frequency of the transmitted wave
 - b. The impedance match of the transmission line
 - c. The direction of the electric field lines of force
 - d. The direction of the receiving station
-

Item 2 The two types of antenna polarization are _____ and

- a. transmitting--receiving.
 - b. induction--electro-magnetic.
 - c. horizontal--electrical.
 - d. horizontal--vertical.
-

Item 3 What kind of antenna polarization should you use when working with medium and low frequencies?

- a. Induction
 - b. Horizontal
 - c. Electrical
 - d. Vertical
-

Item 4 Why is it better to use horizontally polarized antennas at high frequencies?

Continued on next page

Lesson 2 Exercise, Continued

Item 5 Which types of polarization should be used at very-high and ultra-high frequencies?

Item 6 Through Item 9 Matching: For items 6 through 9, match the polarization benefit in column 1 to the type of polarization in column 2. Place your responses in the spaces provided.

Column 1

Column 2

Polarization Benefit

Type of Polarization

- ___ 6. Minimizes interference from certain directions
- ___ 7. Provides the ability to communicate with a moving vehicle
- ___ 8. Somewhat less effected by aircraft flying over the transmission path
- ___ 9. Suffers lower losses when located near dense forests

- a. Vertical
 - b. Horizontal
-

Lesson 2 Exercise

Solutions

The table below lists the solutions to the exercise items. If you have any questions about these items, refer to the reference page.

Item Number	Answer	Reference
1	c	3-12
2	d	3-12
3	d	3-14
4	They can be made to radiate effectively at high angles and have inherent directional properties.	3-14
5	Vertical or horizontal	3-14
6	b	3-16
7	a	3-15
8	a	3-15
9	b	3-16

Summary

In this lesson, you've learned about horizontal and vertical polarization and the advantages of each.

In the next lesson, you will learn about conventional antenna systems currently in use in the Marine Corps.

LESSON 3

CONVENTIONAL ANTENNAS

Overview

Introduction Conventional antennas are antennas manufactured to operate in certain frequency ranges. These versatile antennas are normally sought after by the Marine Corps for their ability to be fielded individually or as a component of an existing communication system.

Content This lesson introduces you to the most common conventional antennas in the Marine Corps arsenal, the AS-2259/GR and the OE-254/GRC.

Learning Objectives At the end of this lesson, you should be able to

- Describe the antenna system AS-2259/GR.
- Describe the antenna system OE-254/GRC.
- State the purpose of the balun on the OE-254/GRC antenna system.

In This Lesson This lesson contains the following topics:

Topic	See Page
Overview	3-21
Antenna System AS-2259/GR	3-22
Antenna System OE-254/GRC	3-25
Lesson 3 Exercise	3-29

Antenna System AS-2259/GR

Definition

The AS-2259/GR manpack, HF antenna is essentially a dipole antenna fed with a low-loss, foam-dielectric, coaxial mast that also serves as a support structure. The dipole system uses a set of crossed sloping dipoles positioned at right angles to each other. Physically, the antenna consists of eight lightweight coaxial mast sections and four radiating elements that also serve as guy lines. The antenna is transported in a canvas pack similar to a tool roll. The total packed weight of the antenna is 14.7 pounds. Two Marines can erect this antenna in 5 minutes without the use of any tools. The antenna is shown in the diagram below:

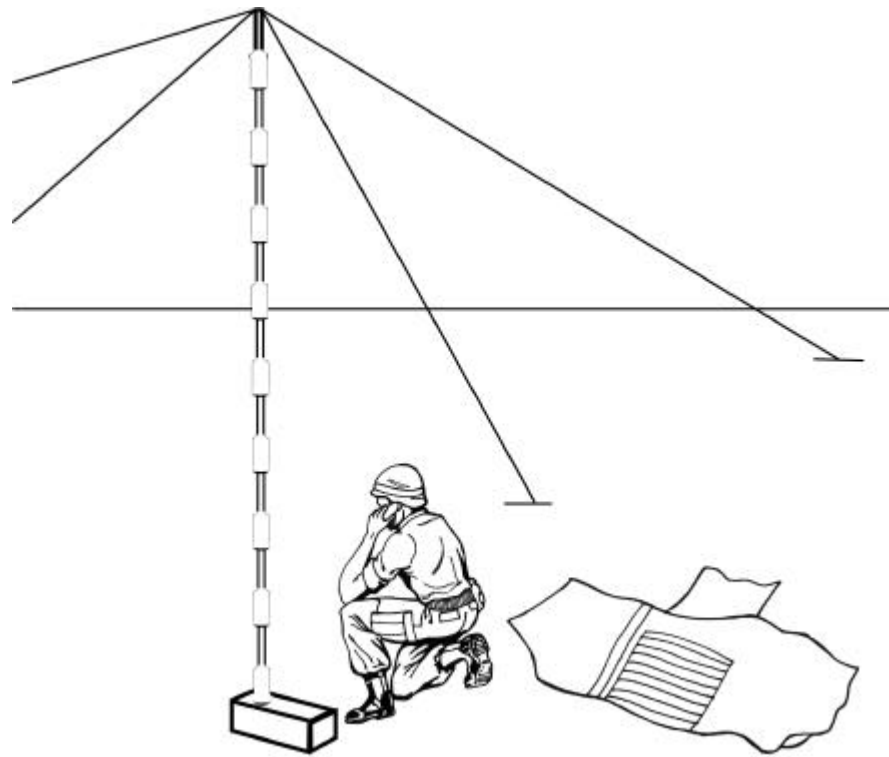

Continued on next page

Antenna System AS-2259/GR, Continued

How It Works The AS-2259/GR antenna is designed to provide high-angle radiation (near vertical incidence) to permit short-range sky wave propagation over communication circuits ranging from 0 to 300 miles. The AS-2259/GR may be used with tactical HF radios that tune a 15-foot whip antenna such as the AN/GRC-193 or AN/MRC-138. The frequency range of the antenna is 2.0 to 12.0 MHz and maximum RF power capacity is 100 watts pep or average.

Electrical Characteristics Electrical characteristics for the AS-2259/GR are listed in the table below. Personnel should become thoroughly familiar with data and procedures contained in the entire instruction manual before working with this antenna.

Item	Electrical Characteristics
Frequency range	2.0 to 12.0 MHz
Polarization	Horizontal and vertical simultaneously
RF power capacity	100 watts pep or average
Input impedance	Compatible with output of radios using 15-foot whips such as the AN/PRC-104
Radiation pattern	
Azimuth	Omni-directional
Elevation	Near vertical incidence
Gain	Similar to a dipole mounted horizontally 10 feet above the same type ground

Continued on next page

Antenna System AS-2259/GR, Continued

Physical Characteristics

Physical characteristics for the AS-2259/GR are listed in the table below. Personnel should become thoroughly familiar with data and procedures contained in the entire instruction manual before working with this antenna.

Item	Physical Characteristics
Wind and ice	Survives 60-mph wind with no ice
Height erected	15 feet
Land area required	60 by 60 feet
Erection time	Two Marines: 5 minutes One Marine: 15 minutes
Packed weight	Less than 14.7 pounds

Ancillary Equipment

A description of the ancillary equipment accompanying the AS-2259/GR is listed in the table below.

Military Type Number	Description of Equipment
AS-2259/GR	An antenna that may be used directly with HF manpack radios that tune a 15-foot whip antenna such as the AN/PRC-104. The antenna is rated at 100 watts pep or average RF power.
MX-9313/GR	An adapter for mounting the antenna on vehicles or shelters equipped with HF radios. Adapts antenna AS-2259/GR to the AN/MRC-138 and similar radios employing 1-inch, 8 threads per inch whip bases and automatic couplers.

More Information

For more information on antenna system AS-2259/GR, see TM-07508A-14 or MCI 2532, *HF/UHF Field Radio Equipment*.

Antenna System OE-254/GRC

Definition Antenna group OE-254/GRC is an omni-directional, biconical antenna designed for broadband operation without field adjustment from 30 to 88 MHz, up to 350 watts.

The OE-254/GRC is intended for use with Marine Corps VHF radios such as the AN/PRC-119A, AN/VRC-88 through 90, and the AN/MRC-145A as well as similar radios operating between 30 and 88 MHz.

Components The OE-254/GRC components are listed below:

- Antenna AS-3166/GRC
 - Feedcone assembly
 - Balun assembly
 - Antenna elements
 - Mast AB-1244/GRC
 - Cable assembly CG-1889C/U
-

Mechanical Assembly The feedcone assembly mounts the six antenna elements and the balun assembly, which provides for mechanical connection to the mast by use of an insulating extension.

Electrical Assembly The balun assembly is connected electrically to the radio set using the cable assembly, and elevated up to 31 feet and 2 inches using the mast assembly. The extended radials that make up the antenna elements are copper plated, painted tubes of high-strength steel that are screwed together and then screwed into a central balun.

Transport The equipment is designed for hand or vehicular transportation. When disassembled, the above mentioned items and their associated stakes, guy lines and rings, hammer and baseplate are stowed in a roll type transit bag.

Continued on next page

Antenna System OE-254/GRC, Continued

Diagram

The assembled OE-254/GRC is shown in the diagram below:

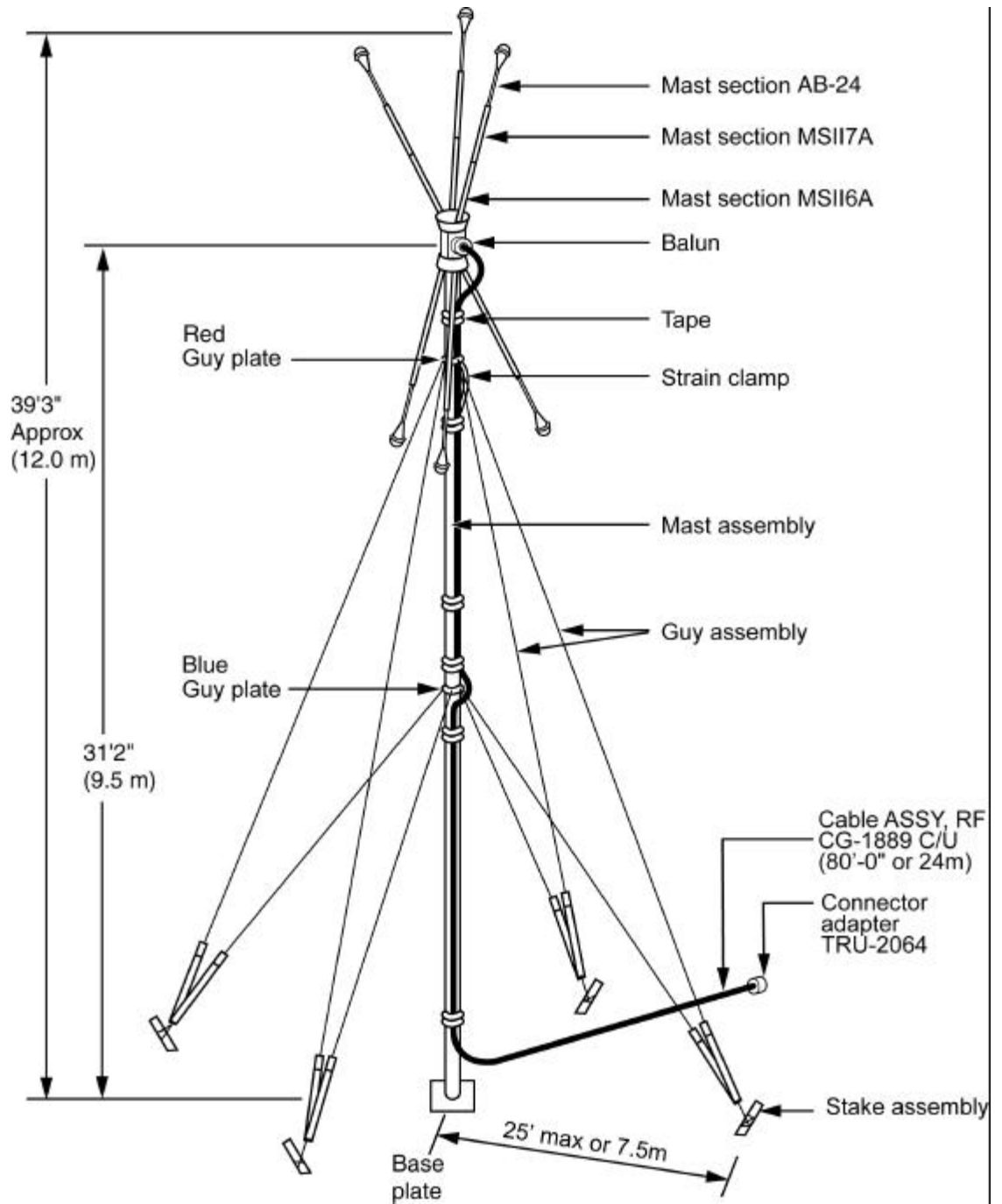

Continued on next page

Antenna System OE-254/GRC, Continued

How it Works The antenna itself consists of three upward and three downward extended radials that simulate two cones that are electrically above ground, making the overall antenna balanced. The extended radials project from the balun at an angle of 30 degrees from true vertical as shown in the diagram on the previous page.

Impedance Matching The nominal impedance of this biconical antenna is 200 ohms requiring the use of a balun transformer to match this balanced impedance to the 50 ohm unbalanced output impedance of the radio to which the AS-3166/GRC is connected. The impedance transformation is accomplished on the AS-3166/GRC through the 4 to 1 balun (balanced to unbalanced) transformer attached between the two cones.

Mast Construction The mast consists of five upper and five lower mast sections, and a mast and base assembly rising to a height of approximately 28 feet 3 inches. Each mast section has a female and male end that permits the sections to be fitted together.

Electrical Characteristics Electrical characteristics for the OE-254/GRC are listed in the table below. Personnel should become thoroughly familiar with data and procedures contained in the entire instruction manual before working with this antenna.

Item	Electrical Characteristics
Frequency range	30.0 to 88.0 MHz
Polarization	Horizontal and vertical simultaneously
RF power capacity	350 watts nominal
Input impedance	50 ohms
Radiation pattern	Non-directional

Continued on next page

Antenna System, OE-254/GRC, Continued

Physical Characteristics

Physical characteristics for the OE-254/GRC are listed in the table below. Personnel should become thoroughly familiar with data and procedures contained in the entire instruction manual before working with this antenna.

Item	Physical Characteristics
Height erected	39 feet and 3 inches
Land area required	80 by 80 feet
Erection time	One Marine: 15 minutes
Packed weight	Approximately 42 pounds

More Information

For more information on the OE-254/GRC, see TM-11-5985-357-13.

Lesson 3 Exercise

Directions Complete items 1 through 8 by performing the action required. Check your answers against those listed at the end of this lesson.

Item 1 The AS-2259/GR makes use of short-range sky wave propagation to communicate over distances ranging from _____ miles.

- a. 0 to 150
 - b. 0 to 200
 - c. 0 to 250
 - d. 0 to 300
-

Item 2 What is the maximum input power of the OE-254/GRC?

- a. 300 watts
 - b. 350 watts
 - c. 400 watts
 - d. 3,500 watts
-

Item 3 What is the purpose of the balun on the OE-254/GRC?

Continued on next page

Lesson 3 Exercise, Continued

Item 4 Through Item 8 Matching: For items 4 through 8, match the antenna characteristic in column 1 to the antenna system in column 2. Place your responses in the spaces provided.

Column 1

Antenna Characteristic

- ___ 4. Operates in a VHF range between 30 and 88 MHz
- ___ 5. An omni-directional, biconical antenna
- ___ 6. Utilizes four radiating elements that serve as guy lines
- ___ 7. Operates in a HF range between 2 and 12 MHz
- ___ 8. Radiating elements are steel tubes that are screwed together into a central balun

Column 2

Antenna System

- a. AS-2259/GR
 - b. OE-254/GRC
-

Lesson 3 Exercise

Solutions

The table below lists the solutions to the exercise items. If you have any questions about these items, refer to the reference page.

Item Number	Answer	Reference
1	d	3-23
2	b	3-27
3	To match the unbalanced, 50 ohm impedance of VHF radio equipment to the balanced, 200 ohm impedance of the biconical antenna array	3-27
4	b	3-27
5	b	3-25
6	a	3-22
7	a	3-23
8	b	3-25

Summary

In this lesson, you've learned about the AS-2259/GR and the OE-254/GRC antenna systems.

In the next lesson, you will learn about field expedient antennas that can be constructed using simple materials.

(This page left intentionally blank.)

LESSON 4

FIELD EXPEDIENT ANTENNAS

Overview

Introduction Sometimes an antenna manufactured to operate across a wide spectrum of frequencies is not efficient enough to accomplish the mission at hand, or too cumbersome to carry or set up. At these times, the field Marine can benefit from an antenna custom built to operate at a specific frequency, an antenna that takes into consideration key factors such as terrain, and time.

Content This lesson introduces you to actual field expedient antennas that can be constructed using the materials and instructions found in Appendix A.

Learning Objectives At the end of this lesson, you should be able to

- Identify the different kinds of field expedient antennas.
- State how to obtain optimum performance from a long wire antenna.
- State what happens to a half-rhombic antenna when terminated in a resistor.
- State the length for which the vertical and ground plane elements for an expedient ground plane antenna should be cut.

In This Lesson This lesson contains the following topics:

Topic	See Page
Overview	3-33
Half-Wave Dipole	3-34
Two-Element Yagi	3-36
Long Wire Antenna	3-37
Half-Rhombic Antenna	3-39
Sloping “V” Antenna	3-40
Vertical Quarter Wave Whip Antenna	3-41
Field Expedient Ground Plane Antennas	3-42
Lesson 4 Exercise	3-43

Half-Wave Dipole

Characteristics The half-wave dipole antenna shown in the diagram below consists of two conductors, each a quarter wavelength, separated in the middle by an insulator. The feed lines are connected to the two separated conductors. The antenna is then supported along a straight line by means of ropes tied from the ends of the antenna to supporting structures such as buildings, trees, poles, etc. Current is maximum at the center and minimum at the ends. Voltage is maximum at the ends and minimum at the center.

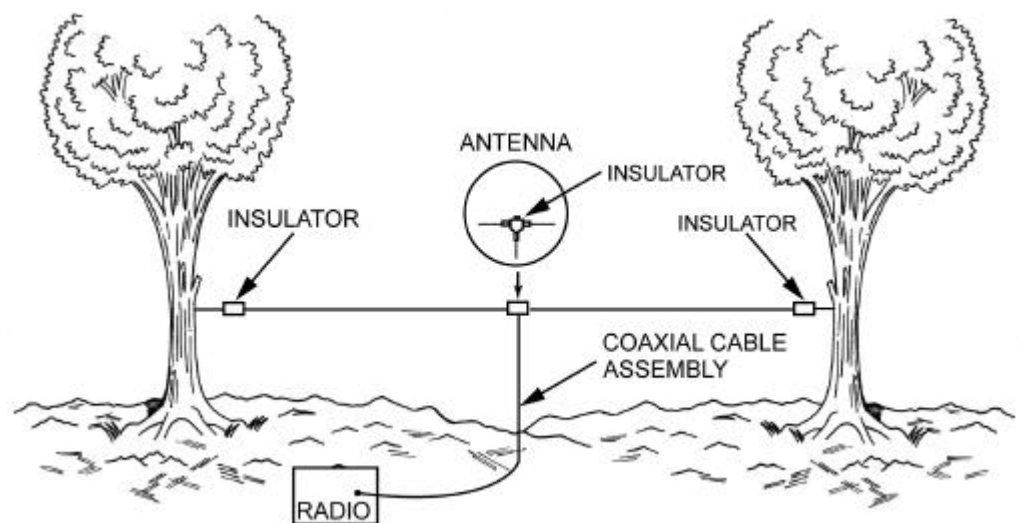

Continued on next page

Half-Wave Dipole, Continued

Radiation Pattern

The half-wave dipole antenna can be mounted in either a vertical, horizontal, or diagonal position. Its radiation pattern is pictured in the diagram below, where the antenna shown is positioned vertically. Maximum radiation is perpendicular to the antenna axis. Since there is no radiation from the ends of the antenna, a figure-8-type pattern is present in the vertical plane. Thus, the antenna is bi-directional in the vertical plane. As shown, radiation is constant in any direction in the horizontal plane. Mounting the antenna horizontally would reverse the pattern illustrated below.

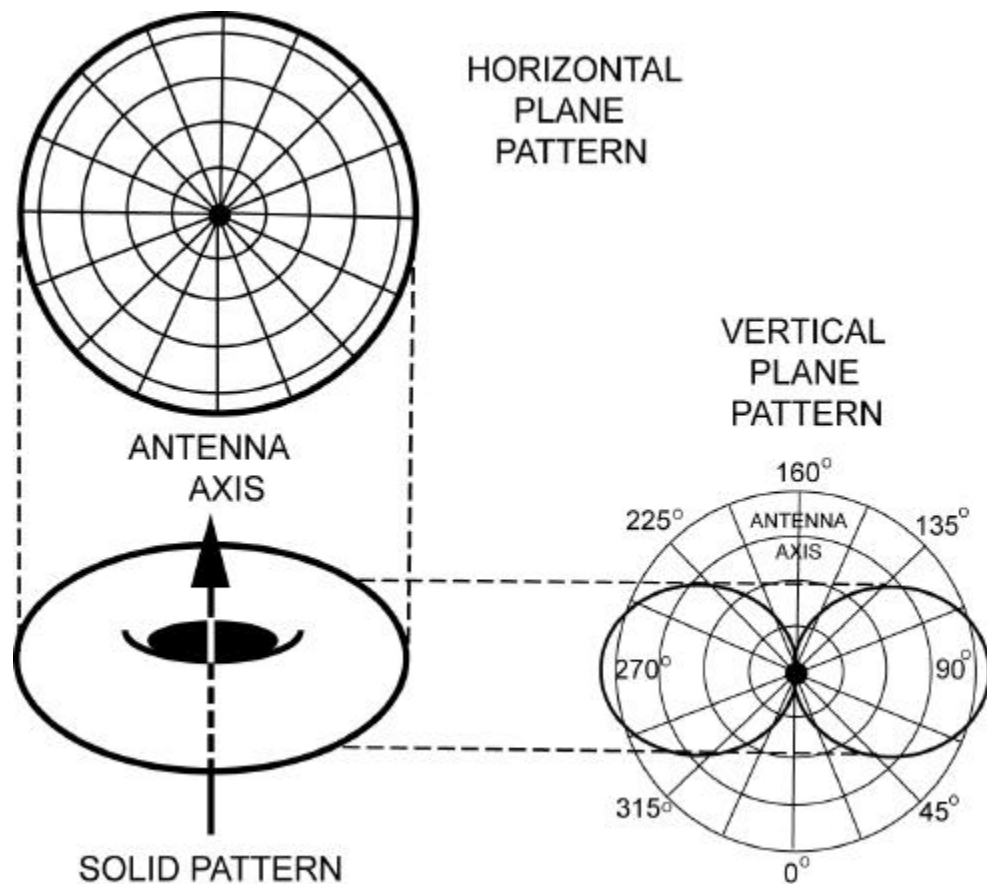

Construction

Instructions for constructing this antenna can be found in Appendix A, Bi- and Uni-Directional Antenna Construction.

Continued on next page

Two-Element Yagi

Characteristics This configuration may be new to most communicators. As seen in the diagram below, this antenna consists of a reflecting element (a single wire) mounted one quarter-wavelength behind a dipole antenna. This additional element substantially increases the gain and makes the antenna more directional.

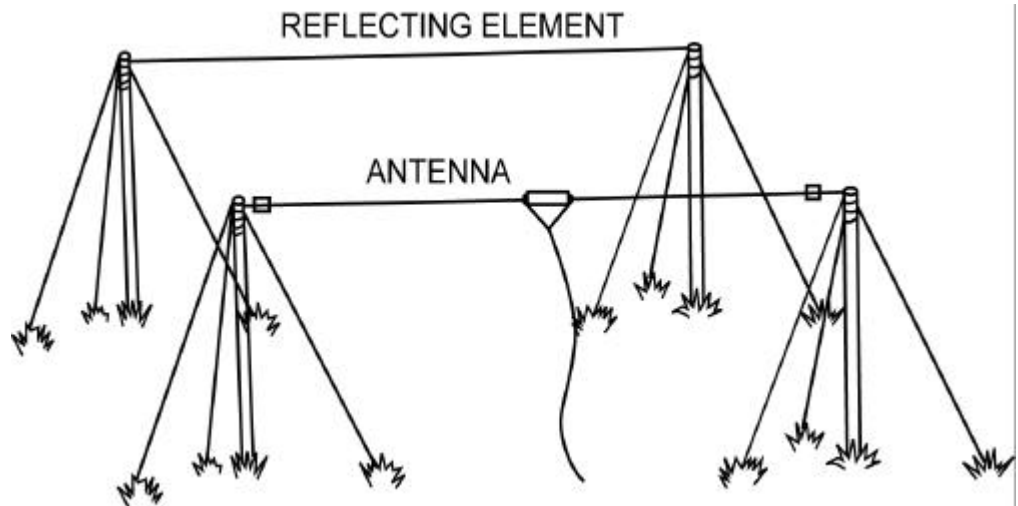

Construction Instructions for constructing this antenna can be found in Appendix A, Bi- and Uni-Directional Antenna Construction.

Long Wire Antenna

Characteristics The long wire antenna shown in the diagram below is a single wire, two to six wavelengths long, suspended one-half wavelength above the ground. Compared to other field expedient antennas, the long wire antenna has greater gain and directivity. This high gain, coupled with the low elevation angle of its main radiation lobe, makes the long horizontal wire antenna one of the simplest antennas to erect.

The long wire antenna is capable of spanning distances in excess of 70 miles and is one of the most practical antennas for use against jamming. The long wire antenna is bi-directional or uni-directional.



Radiation Pattern

The radiation pattern of a long wire antenna is comprised of a series of lobes as shown in the diagram below. As a result of this lobe pattern, best performance is obtained by directing a major lobe toward the intended receiver.

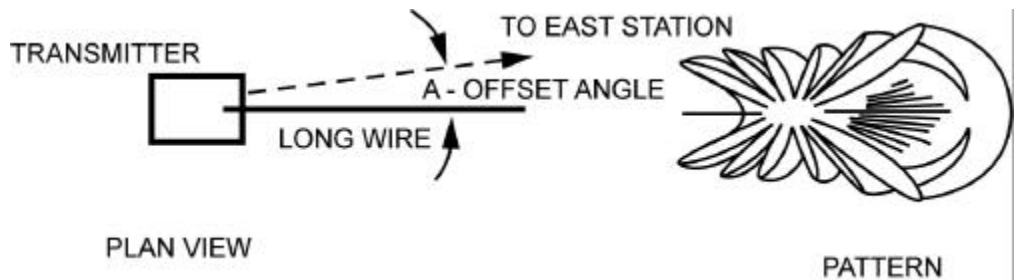

Continued on next page

Long Wire Antenna, Continued

Alignment

To properly align the long wire antenna to the distant station add or subtract the wave angle according to the table below. Keep in mind the wave angle is dependent upon the length of the antenna, as well as the operating frequency.

Offset Angle for the Long Wire Antenna

Freq (MHz)	Wire Length (Meters)					Height (Meters)
	10	20	40	80	150	
10			43°	27°	16°	30.0
12		55°	38°	23°	13°	25.0
14		51°	35°	21°		21.4
16		49°	31°	19°		18.7
18		47°	29°	17°		16.7
20		43°	27°	16°		15.0
24	55°	38°	23°			12.5
30	50°	33°	20°			10.0

Construction

Instructions for constructing this antenna can be found in Appendix A, Bi- and Uni-Directional Antenna Construction.

Half-Rhombic Antenna

Characteristics The half-rhombic antenna shown below is a terminated vertical antenna that resembles an obtuse angle "V" antenna. With the half-rhombic antenna, an unbalanced transmission line and a ground or counterpoise is used. As a result, a vertically polarized radio wave is produced and the antenna is bi-directional. The antenna can be made to be uni-directional by connecting a resistor of about 500 ohms between the far end of the antenna and the ground.

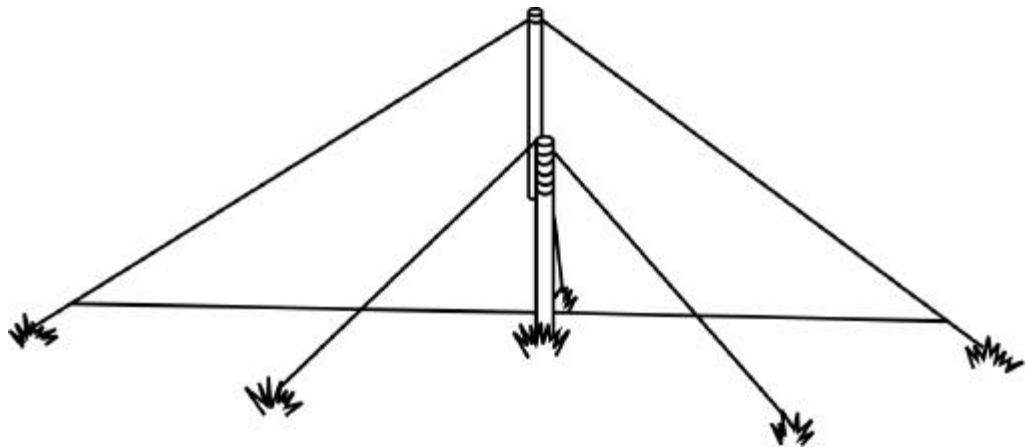

Dimensions The typical military half-rhombic antenna consists of a 100-foot antenna wire erected over a single 30-foot wooden mast and an 85-foot counterpoise wire placed under the antenna about one foot off the ground and attached to both ends of the antenna.

Construction Instructions for constructing this antenna can be found in Appendix A, Bi- and Uni-Directional Antenna Construction.

Sloping "V" Antenna

Characteristics The sloping "V" antenna shown in the diagram below consists of downward sloping long wires arranged to form a "V" and is fed with current of opposite polarity. Major lobes from each wire combine in such a way that maximum radiation occurs in the direction of a lobe that bisects the angle of the legs. The pattern is basically bi-directional along the lines bisecting the angle, producing primarily sky waves.

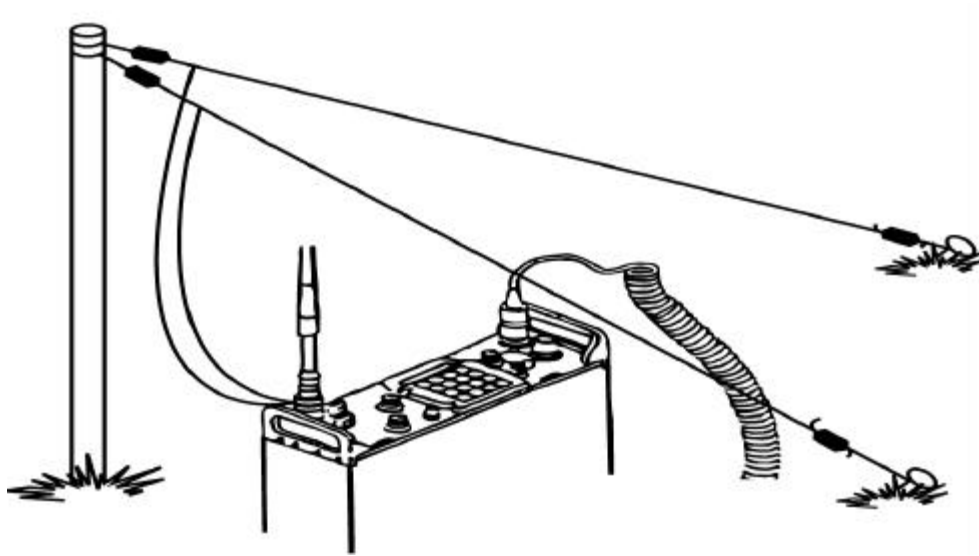

Gain As the leg length of this antenna increases, so does the gain. The gain (increase in effective power or performance) of a "V" antenna is almost double that of a single long wire, since the radiation from the lobes of two waves combine, reinforcing one another. To optimize this reinforcement, use the table found in Appendix A to make sure the accuracy of the apex angle (top angle where the radiating elements meet the mast section).

Directivity The directivity of this antenna also increases with leg length. For maximum efficiency, the legs of the "V" antenna should be cut to three wavelengths at the center frequency of the desired band. The antenna can be made more directional by terminating the individual legs with 500-ohm resistors.

Construction Instructions for constructing this antenna can be found in Appendix A, Bi- and Uni-Directional Antenna Construction.

Vertical Quarter Wave Whip Antenna

Characteristics The vertical whip antenna is the most widely used omni-directional antenna found in the military. The most common example of this type of antenna is the whip antenna used on vehicles, and the ground plane antenna that is usually mounted on masts or other structures. The expedient, vertical quarter-wave, whip antenna, like the antenna shown in the diagram below, is a single bare or insulated wire held vertically by a means of support and connected to the antenna connector on the face of the radio.

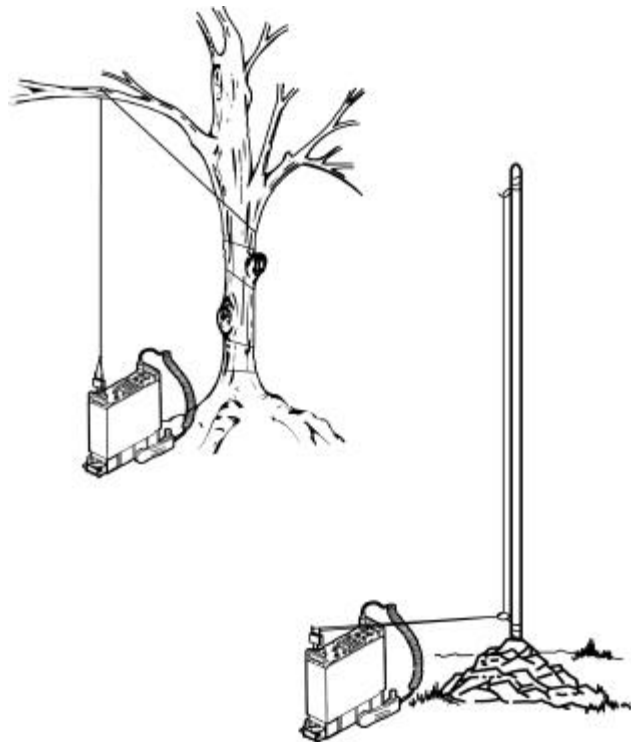

Frequency and Height The vertical whip is omni-directional, and its efficiency is related to the transmitting frequency and antenna height. At lower frequencies, it is rather inefficient, but as the frequency increases so does the efficiency. Antenna height can be improved by placing the antenna on top of a hill or by fastening it to a pole or tree to boost the efficiency of this antenna.

Construction Instructions for constructing this antenna can be found in Appendix A, Omni-Directional Antenna Construction.

Field Expedient Ground Plane Antennas

Characteristics These field expedient antennas operate at frequencies above 20 MHz. They are either pole supported or tree hung, as shown in the diagram below, and their radiation pattern is omni-directional. The vertical and ground plane elements are cut for a quarter wave, the ground plane elements should be at 45-degree angles. Insulators are used to separate vertical elements from the ground plane elements.

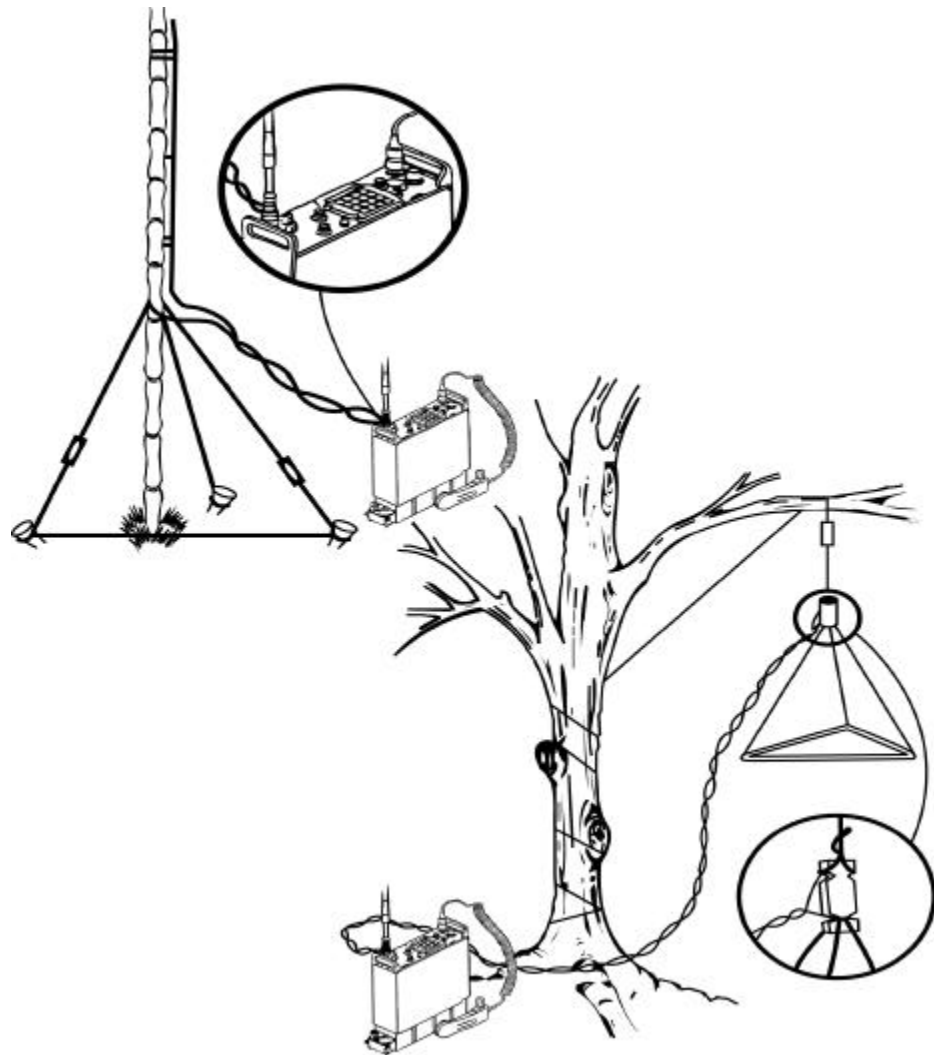

Construction Instructions for constructing this antenna can be found in Appendix A, Bi- and Uni-Directional Antenna Construction.

Lesson 4 Exercise

Directions

Complete items 1 through 10 by performing the action required. Check your answers against those listed at the end of this lesson.

**Item 1
Through
Item 4**

Matching: For items 1 through 4, match the field expedient antenna in column 1 to the illustration in column 2. Place your responses in the spaces provided.

Column 1

Field Expedient Antenna

- ___ 1. Half-wave dipole
- ___ 2. Long wire
- ___ 3. Sloping "V"
- ___ 4. Vertical quarter wave whip

Column 2

Illustration

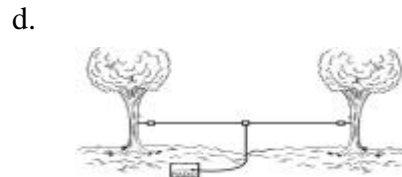
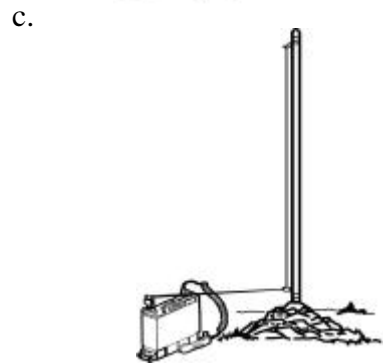
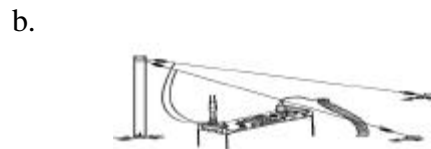

Continued on next page

Lesson 4 Exercise, Continued

**Item 5
Through
Item 7**

Matching: For items 5 through 7, match the field expedient antenna in column 1 to the illustration in column 2. Place your responses in the spaces provided.

Column 1

Field Expedient Antenna

- ___ 5. Two-element yagi
- ___ 6. Half-rhombic
- ___ 7. Ground plane

Column 2

Illustration

a.

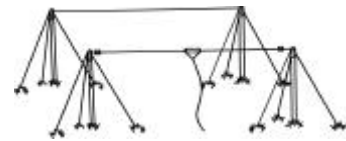

b.



c.



Item 8

Optimum performance can be achieved with the long wire antenna by

- a. terminating one leg of the antenna with a 500-ohm resistor.
- b. placing a reflecting element behind the radiating element.
- c. mounting the antenna in a vertical or diagonal position.
- d. directing a major lobe toward the intended receiver.

Continued on next page

Lesson 4 Exercise, Continued

Item 9

Terminating a half-rhombic antenna with a resistor causes it to become

- a. omni-directional.
 - b. uni-directional.
 - c. bi-directional.
 - d. directional.
-

Item 10

What length should the vertical and ground plane elements be cut for an expedient ground plane antenna?

- a. One-quarter wave
 - b. One radio wave
 - c. One-half wave
 - d. One full wave
-

Lesson 4 Exercise

Solutions

The table below lists the solutions to the exercise items. If you have any questions about these items, refer to the reference page.

Item Number	Answer	Reference
1	d	3-34
2	a	3-37
3	b	3-40
4	c	3-41
5	a	3-36
6	b	3-39
7	c	3-42
8	d	3-37
9	b	3-39
10	a	3-42

Summary

In this lesson, you've learned about many different types of field expedient antennas.

In the next lesson, you will learn about the different types of transmission lines and the role they play in effective communications.

LESSON 5

TRANSMISSION LINES

Overview

Introduction It is important to realize that the feed in line, or transmission line, which connects the radio to the antenna, is a crucial part of the communication system. Using an unsuitable transmission line can render the most carefully constructed antenna inefficient, or damage costly communications equipment.

Content This lesson discusses the different types of transmission lines and the phenomenon of standing waves that can plague any transmission line.

Learning Objectives At the end of this lesson, you should be able to

- Define transmission line.
- Identify the different types of transmission lines.
- Define standing waves.

In This Lesson This lesson contains the following topics:

Topic	See Page
Overview	3-47
Types of Transmission Lines	3-48
Standing Waves	3-52
Lesson 5 Exercise	3-53

Types of Transmission Lines

Definition

A transmission line is a conductor that transfers radio frequency (RF) energy from the transmitter to the antenna or from the antenna to the receiver. Most radio systems and preconstructed antennas are fielded with custom transmission lines, cut to the appropriate length and fitted with any necessary end connectors.

For the purpose of building field expedient antennas or repairing conventional antennas, the transmission lines discussed in the following pages can be purchased by the foot through the Marine Corps supply system as well as electronic hobbyist stores or web sites.

Balanced and Unbalanced

Transmission lines fall into two main categories:

- Balanced lines
- Unbalanced lines

The terms balanced and unbalanced describe the relationship between the transmission line conductors and the earth.

Balanced

The balanced line is composed of two identical conductors, usually circular wires separated by air or an insulating material. The voltages between each conductor and ground, produced by an RF wave as it moves down a balanced line, are equal and opposite.

For example, at the moment one of the conductors supports a positive voltage with respect to ground, the other supports a negative voltage of equal magnitude. Some balanced transmission lines carry a third conductor; sometimes in the form of a braided shield which acts as a ground.

Continued on next page

Types of Transmission Lines, Continued

Unbalanced

Unbalanced lines are usually seen in the form of an open single wire line or coaxial cable. The unbalanced line can be imagined as just one-half of a balanced line. Examples of both balanced and unbalanced lines are shown in the diagram below.

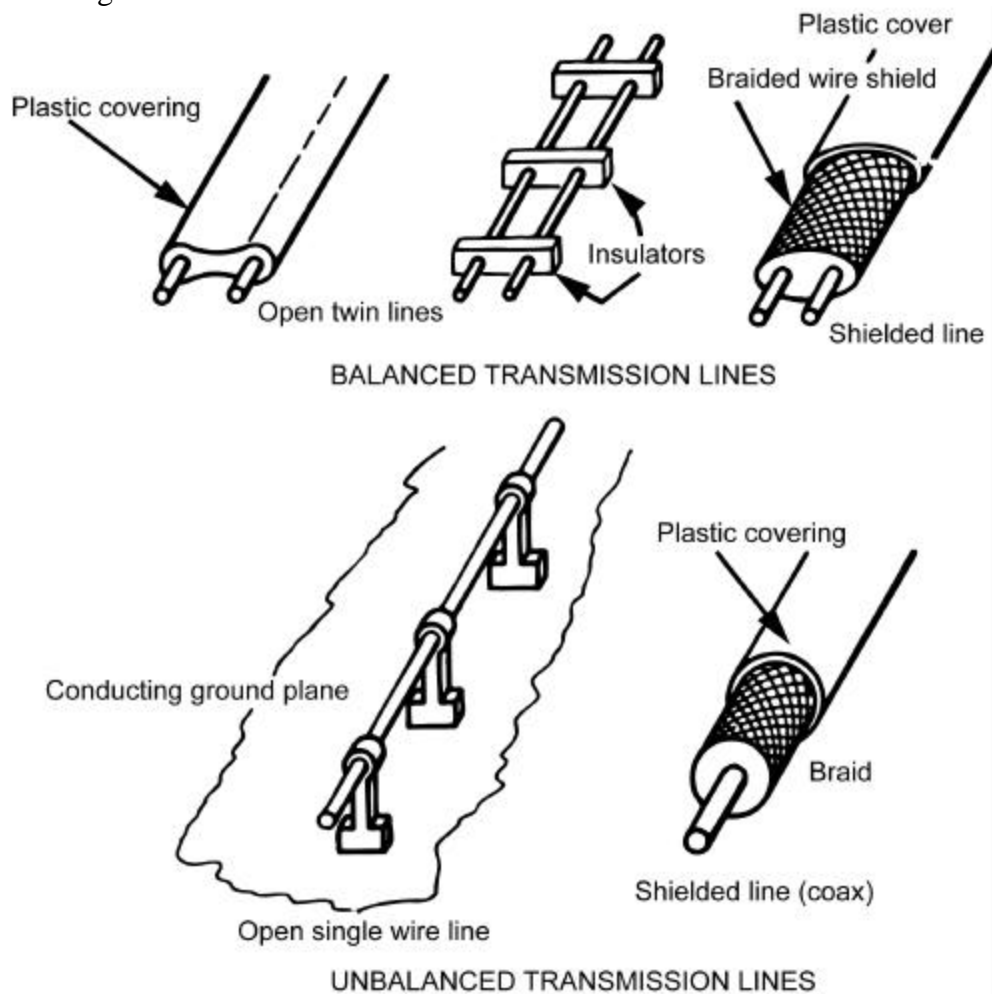

Continued on next page

Types of Transmission Lines, Continued

Parallel Two-Wire

The parallel two-wire line shown below consists of two parallel conductors separated by insulators or spreaders at various intervals. It is available in two types: spreader bar and twin lead. The spreader bar type uses ceramic or polystyrene bars as spacers between the two conductors. The impedance for this type of line is from 50 to 700 ohms. The twin lead consists of two conductors that are molded into a low-loss polyethylene plastic. It is available in impedances ranging from 75 to 300 ohms.

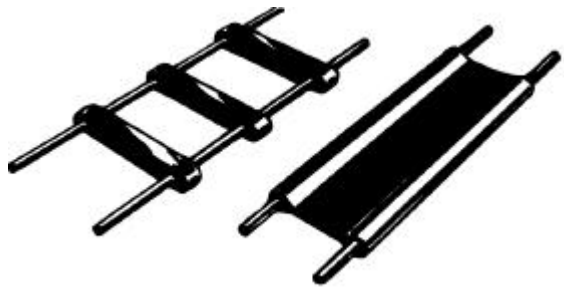

Twisted Pair

The twisted pair transmission line shown in the diagram below consists of two insulated conductors twisted together. The purpose of twisting the lines together is to give the line greater strength and to cancel out the effects of nearby magnetic or electric fields. The impedance of twisted pair line is generally 70 to 100 ohms. The advantages of this type of line are ease of construction and accessible material. The disadvantages of using the twisted pair transmission lines are that some RF loss in transmission line power may occur and extreme care must be taken when using this type of transmission line with HF or high-powered equipment.



Continued on next page

Types of Transmission Lines, Continued

Shielded Pair

The shielded pair transmission line shown below consists of two conductors separated and surrounded by insulation material. The insulation material is then covered with a flexible copper braid that acts as a shield. This shield is then coated with rubber or a similar material to protect it against moisture and friction. Because of the shield, the line is not effected by nearby electric or magnetic fields. Shielded pair transmission lines have the benefit of center conductors that are balanced to ground and uniform capacitance across the entire length of the line. This balance is due to the grounded shield that surrounds the conductor with a uniform spacing along the entire length.



Coaxial Cable

The coaxial transmission line shown below consists of two conductors, a center conductor and an outer shield. The center conductor can be a solid strand of copper or two or more small strands of copper twisted together. A polyethylene plastic shell surrounds the center conductor and provides uniform characteristics throughout the cable. The outer conductor is a flexible copper braid allowing this cable to carry high frequencies with minimal RF loss. This ability to carry high frequencies with very low loss or risk of RF radiation makes the coaxial cable the most widely used cable in Marine Corps conventional antennas and communications systems. The advantages of the coaxial cable are that it is waterproof and durable, easy to work with, safe from shock hazard when constructed properly, and readily available. The disadvantage of this cable is its high cost.



Standing Waves

Definition A standing wave is a motionless wave on an antenna that can cause voltage and current to be reflected back down the transmission line into the transmitter. Standing waves result in power loss and poor antenna efficiency.

Impedance Impedance describes the nature and size of anything that impedes the flow of current; in the case of antennas and transmission lines, RF waves. Any circuit that contains capacitance or inductance and operates at some frequency has impedance. Impedance, like resistance, is expressed in *ohms*, but cannot be measured with an ordinary ohmmeter.

Impedance Mismatch The impedance of an antenna at the point where the transmission line (also called a feed line) is attached is called the antenna input impedance. For maximum efficiency, an antenna must be the proper length for the frequency at which it operates. Just as important, the characteristic impedance or impedance of the transmission line and the antenna input impedance must match. Additionally, the output impedance of the transmitter must match the impedance of the feed line. If a mismatch occurs anywhere in the antenna system, standing waves will result.

Standing Wave Ratio Most military transmitters provide 50-ohm impedance at the antenna output. Most expedient half-wave antennas have approximately a 70-ohm impedance. By matching the transmission line to the transmitter with a 50-ohm line, a 20-ohm difference at the antenna results or by matching the transmission line to the antenna with a 70-ohm line, a 20-ohm difference at the transmitter results. If you were to transmit in this mismatched state, a standing wave would be produced. Comparing the amplitude of this standing wave with the output of the transmitter results in an efficiency rating known as the standing wave ratio (SWR). By dividing 70 ohms by 50 ohms, you will see that the SWR is 1.4 to 1. For safety reasons and for the good of the equipment, it is recommended that you not operate a system with a mismatch or SWR greater than 1.5 to 1.

Lesson 5 Exercise

Directions Complete items 1 through 9 by performing the action required. Check your answers against those listed at the end of this lesson.

Item 1 Through 4 Matching: For items 1 through 4, match the type of transmission line in column 1 to the illustration in column 2. Place your responses in the spaces provided.

Column 1

Type of Transmission Line

- ___ 1. Shielded pair
- ___ 2. Twisted pair
- ___ 3. Parallel two-wire
- ___ 4. Coaxial cable

Column 2

Illustration

a.



b.



c.



d.



Continued on next page

Lesson 5 Exercise, Continued

Item 5

Define transmission line.

Item 6

What are standing waves?

Item 7

What are the advantages of using twisted pair transmission line?

- a. Economical and safe with high powered equipment
 - b. Ease of construction and accessible material
 - c. Waterproof, lightweight, and easy to handle
 - d. Carries high frequencies with minimal loss
-

Item 8

A disadvantage of using twisted pair transmission line is that it is

- a. extremely expensive.
 - b. dangerous with HF.
 - c. dangerous with RF.
 - d. not waterproof.
-

Item 9

Name one advantage of using a shielded pair transmission line.

- a. It has very high impedance.
 - b. It has uniform capacitance.
 - c. It has no outer shielding.
 - d. Ease of construction.
-

Lesson 5 Exercise

Solutions

The table below lists the solutions to the exercise items. If you have any questions about these items, refer to the reference page.

Item Number	Answer	Reference
1	b	3-51
2	c	3-50
3	a	3-50
4	d	3-51
5	A conductor that transfers radio frequency (RF) energy from the transmitter to the antenna or from the antenna to the receiver	3-48
6	A motionless wave on an antenna	3-52
7	b	3-50
8	b	3-50
9	b	3-51

Summary

In this study unit, you've learned about the functions of an antenna. You learned about antenna polarization, the polarization requirements of various frequencies, and the conventional field antennas used within the Marine Corps. You have also learned several types of field expedient antennas and several types of transmission lines that can be used to feed these antennas.

In the next study unit, you will learn about selecting a suitable communications site and proper antenna grounding.

STUDY UNIT 4

SITE SELECTION AND ANTENNA GROUNDING

Overview

Introduction

Two factors play an important role in selecting a communications site: optimum communications and camouflage. Unfortunately, it is seldom possible to situate your equipment in a position conducive to good communication and yet be hidden from enemy view, fire, or direction finding efforts. From a communications point of view, the ideal location for a radio antenna is far away from cover on a bare mountaintop or in the middle of a large field. Obviously, this does mesh with the tactical requirement to be hidden from the enemy's view.

Because you cannot always obtain the best locations for your antenna sites, antenna grounding is also an important factor to consider. Usually the most frequent cause of a weak signal, especially HF signals, is poor grounding. You can easily increase your communication distance by properly grounding the antenna.

WARNING: Ungrounded high-powered transmitters can damage equipment or shock, burn, or kill Marines.

Scope

This study unit discusses the technical and tactical requirements crucial to proper site selection. This study unit also discusses various counter measures and precautions that can be taken when selecting an antenna site. Lastly, this study unit introduces you to various types of grounding equipment.

In This Study Unit

This study unit contains the following lessons:

Topic	See Page
Requirements for Site Selection	4-3
Electronic Warfare Considerations	4-11
Grounds and Counterpoises	4-17

(This page left intentionally blank.)

LESSON 1

REQUIREMENTS FOR SITE SELECTION

Overview

Introduction The choice of an antenna site will depend on the nature of the local intervening terrain and the tactical situation. Planning should be preceded by a careful study of terrain maps and whenever possible, by reconnaissance, in order to obtain detailed information concerning the availability, accessibility, and feasibility of desirable sites.

Content This lesson discusses the technical and tactical factors that must be taken into consideration when selecting a communications site.

Learning Objectives At the end of this lesson, you should be able to

- Identify the technical factors that influence site selection.
- Identify the tactical factors that influence site selection.

In This Lesson This lesson contains the following topics:

Topic	See Page
Overview	4-3
Technical Factors	4-4
Tactical Factors	4-6
Lesson 1 Exercise	4-8

Technical Factors

Definition Technical factors that effect communications site selection are factors that relate to the characteristics of equipment being used and the nature of the communications mission.

Factors Technical factors that effect communications site selection include

- Location
 - Terrain
 - Ground conditions
 - Foliage
 - Manmade obstructions
 - Bridges
 - Buildings
 - Suspended power lines
 - Roads
 - Other electrical equipment
 - Noisy areas
-

Location A site must be located in a position that will ensure communication with the other stations with which it is to operate. To obtain efficient transmission and reception, the factors listed below should be considered.

Terrain Hills and mountains between stations normally limit the range of radio sets. In mountainous or hilly terrain, positions relatively high on the slopes should be selected. Locations at the base of a cliff or in a deep ravine or valley should be avoided. For operation at frequencies above 30 MHz, a location that will give line-of-sight communication should be selected whenever possible.

Ground Conditions Dry ground has resistance, therefore, limits the range of the radio set. If possible, the station should be located near moist ground, which has much less resistance. Water, and in particular salt water, will greatly increase the distances that can be covered and also provides a better earth ground for the equipment.

Continued on next page

Technical Factors, Continued

Foliage Trees with heavy foliage absorb radio waves, with leafy trees causing a greater detriment than evergreens. The antenna should be kept clear of all foliage and dense brush.

Man-Made Obstructions In addition to the natural obstructions listed on the previous page, many man-made obstructions should be avoided when selecting an antenna site. The most common of these obstructions are listed below.

Bridges A position in a tunnel or beneath an underpass or steel bridge should be avoided. Transmission and reception under these conditions are almost impossible because of high absorption of RF waves.

Buildings Buildings located in the transmission path, particularly steel and reinforced concrete structures hinder transmission and reception.

Suspended Power Lines All types of pole wire lines, such as telephone and high power lines, should be avoided when selecting a site for a radio station. Such wire lines absorb power from radiating antennas located in their vicinity. They also introduce hum and noise interference in receiving antennas.

Roads Positions adjacent to heavily traveled roads and highways should be avoided. In addition to the noise and confusion caused by tanks and trucks, ignition systems in these vehicles may cause electrical interference.

Other Electrical Equipment Avoid electrical interference from other electrical equipment by avoiding the following:

- Other commercial or military communication sites
- Battery charging units
- Generators

Noisy Areas Radio stations should be located in relatively quiet areas. Copying weak signals require great concentration by the operator, and his or her attention should not be diverted by extraneous noises.

Tactical Factors

Definition Tactical factors that effect communications site selection are factors that relate to the military nature of the mission, the threat of enemy attack, and the proximity of enemy forces.

Factors Tactical factors that effect communications site selection include

- Local command requirements
- Cover and concealment
- Terrain and camouflage
- Remote operation
- Local coordination
- Final considerations

Local Command Requirements Communication sites should be located some distance from the unit headquarters or command post that they serve. Thus, long-range enemy artillery fire, missiles, or aerial bombardment directed at the stations as a result of enemy direction finding would not strike the command post area.

Cover and Concealment The locations selected should provide the best cover and concealment possible, consistent with good transmission and reception. Perfect cover and concealment may impair transmission and reception. The amount of permissible impairment depends on the range required, the power of the transmitter, the sensitivity of the receiver, the efficiency of the antenna system, and the nature of the terrain. When a radio is being used to communicate over a distance that is well under the maximum range, some sacrifice of communication efficiency can be made to permit better concealment from enemy observation.

Terrain and Camouflage Open crests of hills and mountains must be avoided. A slightly defiladed position just behind the crest gives better concealment and sometimes provides better transmission. All permanent and semi-permanent positions should be properly camouflaged for protection against both aerial and ground observation. However, the antenna should not touch trees, brush, or camouflage material.

Continued on next page

Tactical Factors, Continued

Remote Operation

Antennas of all radio sets must extend above the surface of the ground to permit normal communications. However, most man-packed radio sets have sufficient cord length to permit operation from cover, while the radio set is below the surface of the surrounding terrain and the antenna is in the clear. Some sets can be controlled remotely from distances of 100 feet or more. Radio sets of this type can be set up in a relatively exposed position while the operator remains concealed.

Local Coordination

Contact must be maintained between the communications site and the message center at all times, either by local messenger or field telephone. The station should also be readily accessible to the unit commander and his or her staff.

Final Considerations

It is almost impossible to select a radio site that will satisfy all technical and tactical requirements. Therefore, a compromise is usually necessary and the best site available is selected. It is also a good idea to select both a primary and an alternate site. Then, if radio communication cannot be established at the primary location, the set can be moved a short distance to the alternate position.

Lesson 1 Exercise

Directions Complete items 1 and 2 by performing the action required. Check your answers against those listed at the end of this lesson.

Item 1 Technical factors that effect communications site selection include

- a. cover and concealment, remote operation, and camouflage.
- b. buildings, roads, and ground conditions.
- c. bridges, buildings, and remote operations.
- d. local command requirements, ground conditions, and foliage.

Item 2 Tactical factors that effect communications site selection include

- a. cover and concealment, remote operation, and camouflage.
- b. buildings, roads, and ground conditions.
- c. bridges, buildings, and remote operations.
- d. local command requirements, ground conditions, and foliage.

Lesson 1 Exercise

Solutions

The table below lists the solutions to the exercise items. If you have any questions about these items, refer to the reference page.

Item Number	Answer	Reference
1	b	4-4
2	a	4-6

Summary

In this lesson, you've learned about technical and tactical factors that are crucial to selecting a communication site.

In the next lesson, you will learn about electronic warfare and how it effects the selection of an antenna site.

(This page left intentionally blank.)

LESSON 2

ELECTRONIC WARFARE CONSIDERATIONS

Overview

Introduction When operating any kind of radio equipment in a tactical environment, it is important to remember the radio waves you are transmitting can give away your position. Our adversaries train and equip directional finding forces with sophisticated equipment that can pinpoint your location if you do not employ the proper counter measures.

Content This lesson discusses electronic warfare (EW) and the counter measures that can be taken to defeat enemy directional finding and jamming efforts.

Learning Objectives At the end of this lesson, you should be able to

- Define antenna masking.
- Identify one advantage of using directional horizontally polarized antennas in an EW environment.

In This Lesson This lesson contains the following topics:

Topic	See Page
Overview	4-11
Antenna Placement	4-12
Antenna Selection	4-14
Lesson 2 Exercise	4-15

Antenna Placement

Placement Utilizing the antenna placement methods described below can greatly improve your chances of defeating enemy radio directional finding (RDF) efforts.

Antenna Masking Antenna masking, like that shown in the diagram below, is the technique of hiding radio signals behind terrain. It is an inexpensive way to confuse RDF efforts. VHF radio waves bend; they are reflected by buildings and mountains and absorbed by trees. When this happens, it is difficult to determine the original direction from which the wave was transmitted, but the ability to hear the signal is minimally effected. A radio operator can advantageously use this principle by attempting to place terrain obstacles between the transmitter and the forward edge of the battle area (FEBA) while affording an unblocked path to the intended receivers. Hills, lakes, and dense forest also provide terrain obstacles. Antenna masking also occurs when antennas are positioned on the back slopes of hills. A radio operator should also erect antennas as low as adequate communications permit and, in all cases, antennas should be camouflaged to blend with terrain.

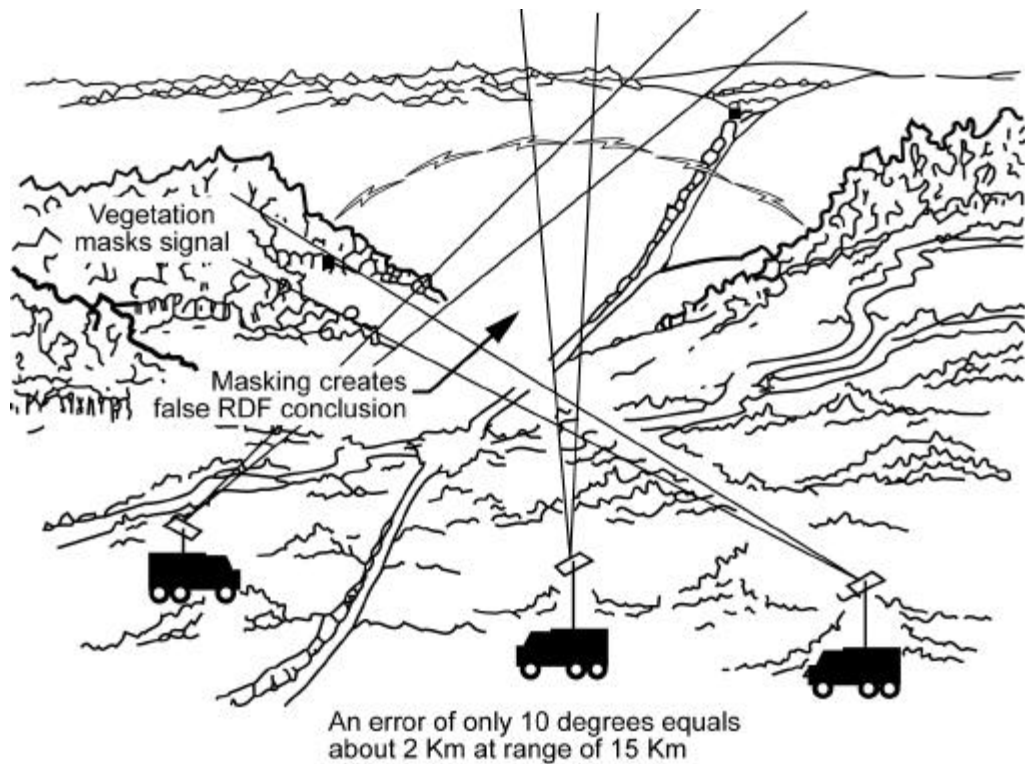

Continued on next page

Antenna Placement, Continued

Antenna Dispersion

When numerous antennas are used, it is important to place them some distance apart from each other so that their cumulative radiation does not appear to be coming from one large source. Good antenna dispersion also means planning for alternate locations, using terrain analysis to find antenna locations that can provide natural masking from the enemy, and employing the services of agencies such as the Joint Spectrum Center (JSC). As you will see in Appendix B, JSC can support the Marine communicator in the field by supplying coverage and propagation predictions that simplify the frequency and location selection process.

Antenna Selection

Importance Choosing the right type of antenna for your mission is as important as selecting the right antenna location. If you carefully select and employ your antennas, direction finding will be more difficult and expensive for your adversaries.

Vertical, Omni-Directional Antennas For versatility, the omni-directional, vertically polarized antenna is best. The flexibility provided by omni-directional antennas is important to the commander during the attack when it is difficult to maintain correct orientation for horizontally polarized directional antennas. Additionally, vertically polarized omni-directional antennas are required for communications between moving vehicles. Unfortunately, the omni-directional antenna has one chief disadvantage—danger. Omni-directional antenna signals travel in a 360-degree radius and usually well across the FEBA where they are susceptible to interception and RDF.

Horizontal, Directional Antennas Horizontally polarized, directional antennas should be considered for lateral communications in an EW environment whenever possible for the following reasons:

- The horizontal antenna produces a more stable signal in the presence of interference (jamming).
 - The horizontal antenna produces a more stable signal when used in or near dense woods.
 - The horizontal antenna is more readily camouflaged without loss of signal.
 - Small changes in antenna location do not cause large variations in signal strength.
 - The horizontal antenna is more difficult to direction find because of polarization and because its signal can be directed to intended recipients and away from enemy RDF in many applications.
-

Lesson 2 Exercise

Directions Complete items 1 and 2 by performing the action required. Check your answers against those listed at the end of this lesson.

Item 1 Define antenna masking.

Item 2 Name one advantage of using horizontal polarization in an EW environment.

Lesson 2 Exercise

Solutions

The table below lists the solutions to the exercise items. If you have any questions about these items, refer to the reference page.

Item Number	Answer	Reference
1	The technique of hiding radio signals behind terrain.	4-12
2	<ul style="list-style-type: none">• The horizontal antenna produces a more stable signal in the presence of interference (jamming).• The horizontal antenna produces a more stable signal when used in or near dense woods.• The horizontal antenna is more readily camouflaged without loss of signal.• Small changes in antenna location do not cause large variations in signal strength.• The horizontal antenna is more difficult to direction find because of polarization and because its signal can be directed to intended recipients and away from enemy RDF in many applications.	4-14

Summary

In this lesson, you've learned about antenna placement and selection techniques that can be used to minimize RDF threat.

In the next lesson, you will learn about grounding and counterpoises.

LESSON 3

GROUNDS AND COUNTERPOISES

Overview

Introduction When grounded antennas are used, it is important that the ground be as conductive as possible. This is necessary to reduce ground losses and to provide the best possible reflecting surface for the radiated energy from the antenna above.

Content This lesson discusses the importance of proper grounding and introduces you to various types of grounding rods, radial grounds, counterpoises, and ground screens.

Learning Objectives At the end of this lesson, you should be able to

- State the purpose of grounds
 - Define grounding rods.
 - Define radial grounds.
 - Describe a counterpoise.
 - Describe a ground screen.
-

In This Lesson This lesson contains the following topics:

Topic	See Page
Overview	4-17
Grounds	4-18
Grounding Rods	4-19
Radial Grounds	4-20
Counterpoise	4-21
Ground Screen	4-22
Lesson 3 Exercise	4-23

Grounds

Definition At low and medium frequencies, the ground normally acts as a sufficiently good conductor, although care must be taken to make connection to the ground in such a way as to introduce the least possible amount of resistance in the ground connection. At higher frequencies, artificial grounds constructed of large metal surfaces are common.

Types of Grounds The ground connection takes many forms, depending on the type of installation and the loss that can be tolerated. For fixed station installations, very elaborate ground systems are used. These are frequently arranged over very large areas so that they operate as part of the reflecting surface in addition to making the connection to ground itself. In many simple field installations, the ground connection is made by means of one or more metal rods driven into the earth.

Soil Conditions Sometimes when an antenna must be erected over soil having a very low conductivity, it is advisable to treat the soil directly to reduce its resistance. In this case, the conductivity can be improved by treating the soil with substances that are highly conductive when in solution. Some of these substances, listed in order of preference, are

- Sodium chloride (common salt)
- Calcium chloride
- Copper sulfate (blue vitriol)
- Magnesium sulfate (epsom salt)
- Potassium nitrate (saltpeter)

The amount required depends on the type of soil and its moisture content. When these substances are used, it is important that they do not get into nearby drinking water supplies.

Ground Rods

Description With a less elaborate ground system, a number of ground rods can be used. These rods usually are made of galvanized iron, steel, or copper plated steel in lengths up to 8 feet. One end of the rod is pointed so that it can be driven easily into the earth. The other end is fitted with some type of clamp, in the case of longer rods, so that the ground lead can be attached. In the case of shorter rods, the other end is usually threaded to allow the connection of additional rods. Some ground rods are supplied with a length of ground lead already attached.

Placement Using several ground rods, 6 to 10 feet apart, connected in parallel, can make a good ground connection. If possible, the rods should be located in a moist section of ground or in a natural or man-made depression that will collect moisture. Ground resistance can be reduced considerably by treating the soil with any of the substances previously mentioned. A trench about a foot deep is dug around each ground rod and filled with some common rock salt, Epsom salt, or any of the other materials mentioned. The trench is then flooded with water, causing the treatment to permeate into the soil. During sustained operations, be sure to replenish the water as needed.

Installation It is important that a low resistance connection be made between the ground wire and the ground rod. The rod should be cleaned thoroughly by scraping or sanding the point where the connection is to be made, and a clean ground clamp installed. A ground wire can then be soldered or joined to the clamp. The joint should be covered with tape to prevent an increase in resistance caused by oxidation.

Alternate Grounds Where more satisfactory arrangements cannot be made, it may be possible to make ground connections to existing devices that are already grounded. Metal structures or underground pipe systems (such as water pipes) commonly are used as ground connections. In an emergency, a suitable ground connection can be obtained by plunging one or more bayonets into the earth. Other field expedient ground rods are metal fence posts, steel reinforcing rods, water pipes, conduit, and metal building frame.

Radial Grounds

Definition

Radial grounds, as shown in the diagram below, consist of a number of bare conductors arranged radially and connected. The conductors, which may be from a tenth to a half-wave length or more, are buried a short distance beneath the surface of the earth. If possible, bare metal plates should be attached to the wire ends that improve the quality of the ground.

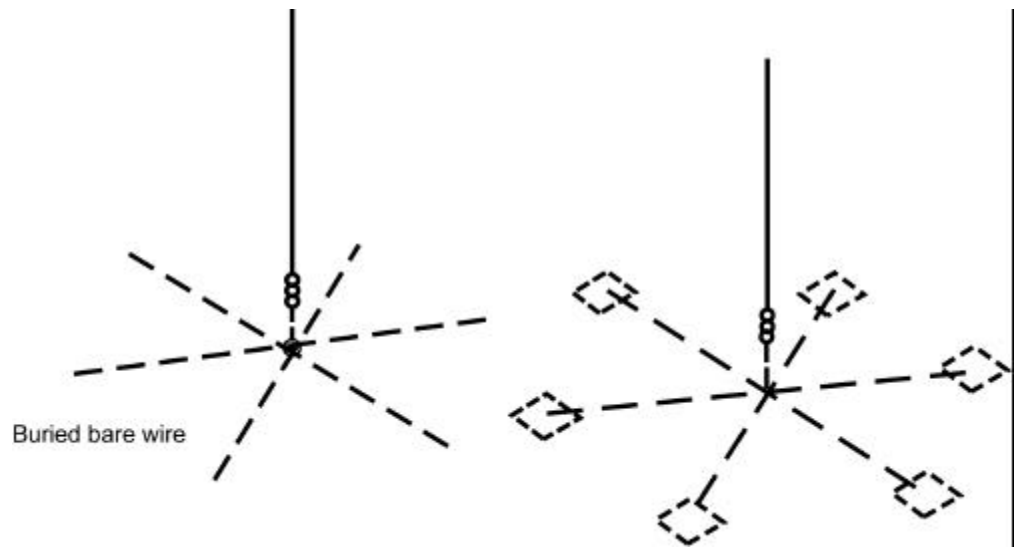

Counterpoise

Definition

When an actual ground connection cannot be used because of the high resistance of the soil or a large buried ground system is not practicable, a counterpoise may replace the usual direct ground connection in which current actually flows to and from the antenna through the ground itself. The counterpoise shown in the diagram below consists of a structure made of wire, which is erected a short distance off the ground and insulated from the ground. The counterpoise should be at least equal to or preferably larger than the antenna.

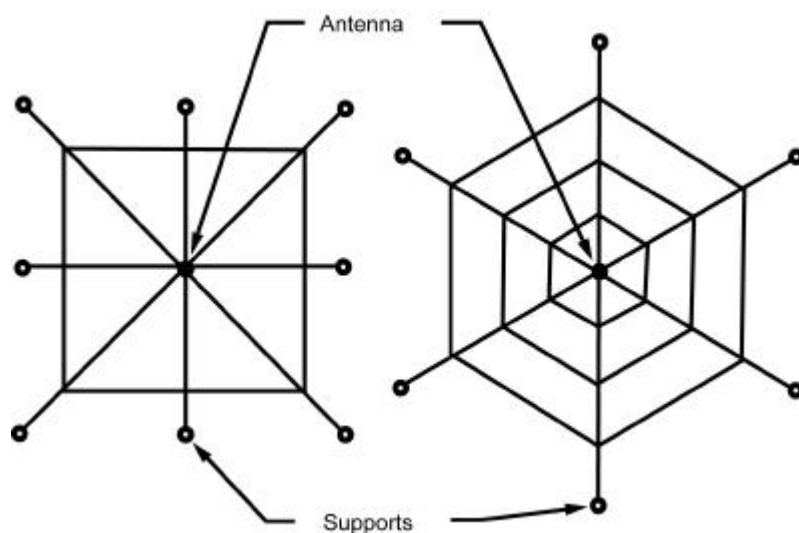

Vertical Antenna Applications

When the antenna is mounted vertically, the counterpoise should be made into a simple geometric pattern such as those shown in the diagram above. Perfect symmetry is not required, but the counterpoise should extend for equal distances in all directions from the antenna.

Vehicular Applications

If some UHF antenna installations are on vehicles, the metal roof of the vehicle is used as a counterpoise for the antenna.

Special VHF Applications

Small counterpoises of metal mesh are sometimes used with special VHF antennas that must be located a considerable distance above the ground. This counterpoise provides an artificial ground that helps to produce the required radiation pattern.

Ground Screen

Definition A ground screen consists of a fairly large area of metal mesh or screen that is laid on the surface of the ground under the antenna. Its purpose is to simulate the effect of a perfect conducting ground under the antenna.

Advantages There are two specific advantages that can be gained through use of a ground screen:

- The ground screen reduces ground absorption losses that occur when an antenna is erected over imperfectly conducting ground.
- The height of the antenna can be set accurately:
 - The radiation resistance of the antenna can be determined.
 - The radiation patterns of the antenna can be predicted more accurately.

Lesson 3 Exercise

Directions Complete items 1 through 5 by performing the action required. Check your answers against those listed at the end of this lesson.

Item 1 The purpose of grounds is to

- have resistance as high as possible.
- have conductivity as low as possible.
- increase ground losses and to provide the best energy from the antenna.
- introduce the least possible amount of resistance in the ground connection.

Item 2 Which of the following is made of galvanized iron, steel, or copper plated steel in lengths of up to 8 feet?

- Ground rod
- Counterpoise
- Radial ground
- Ground screen

Item 3 Which of the following consist of a number of bare conductors arranged and buried a short distance beneath the surface of the earth?

- Ground rod
- Counterpoise
- Radial ground
- Ground screen

Item 4 A structure made of wire that is constructed a short distance off the ground and insulated from the ground describes a

- ground rod.
- counterpoise.
- radial ground.
- ground screen.

Continued on next page

Lesson 3 Exercise, Continued

Item 5

A fairly large area of metal mesh that is placed on the ground directly under the antenna describes a

- a. ground rod.
 - b. counterpoise.
 - c. radial ground.
 - d. ground screen.
-

Lesson 3 Exercise

Solutions

The table below lists the solutions to the exercise items. If you have any questions about these items, refer to the reference page.

Item Number	Answer	Reference
1	d	4-18
2	a	4-19
3	c	4-20
4	b	4-21
5	d	4-22

Summary

In this study unit, you've learned about grounding systems that can be used to enhance the performance of both field expedient and conventional antennas.

The following appendices will aid you in the construction of field expedient antennas and assist you in frequency selection.

(This page intentionally left blank.)

APPENDIX A

FIELD EXPEDIENT ANTENNA CONSTRUCTION

Overview

Introduction

This appendix discusses some field expedient solutions to repairing tactical whip and ground plane antennas if they become broken or damaged. It covers seven field expedient antennas that can be used either alone or in conjunction with conventional tactical antennas.

Scope

This appendix serves as a step-by-step guide to aid you in the repair of common Marine Corps antennas and the fabrication of field expedient antennas. This appendix is a professional reference guide designed to enhance your abilities; this information is not tested in this course.

In This Appendix

This appendix contains the following topics:

Topic	See Page
Overview	A-1
Types of Antennas	A-2
Omni-Directional Antenna Repair	A-3
Omni-Directional Antenna Construction	A-8
Bi- and Uni-Directional Antenna Construction	A-16
Formulas and Quick Reference Charts	A-28
Field Expedient Antenna Supplies	A-31

Types of Antennas

Explanation When fabricating a field expedient antenna, it is important to know the location of the distant station(s) you will need to communicate. The direction and distance of these distant station(s) will determine which type of antenna is used.

Types Basically, there are three types of antennas:

Type	Definition
Omni-directional	All directions
Bi-directional	Any two opposite directions
Uni-directional	Any one direction

Note: The frequency hopping functions are not supported with the expedient antennas.

Examples The three types of antennas are identified in the diagrams below:

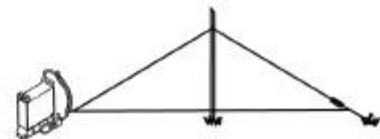
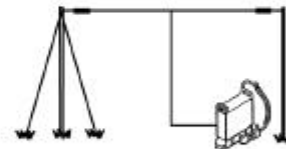

Omni-Directional Antenna Repair

Two Types

There are two types of omni-directional antennas:

- Vertical whip—used on vehicles
 - Metallic whip
 - Fiberglass whip
 - Ground plane—mounted on masts or other structures
-

The Vertical Whip

The vertical whip antenna is the most widely used omni-directional antenna in the military:

- Efficiency relates to the transmitting frequency
 - Lower frequencies—efficiency is very low
 - Higher frequencies—efficiency increases
 - Efficiency interacts with height of antenna
 - Place the antenna on top of a hill
 - Fasten it to a pole or tree to increase its height above surrounding structures
-

Repairs

If your vertical whip antenna is damaged or missing a part, consider the following quick solutions to your problem:

- Metallic whip repair
 - Fiberglass whip repair
-

Continued on next page

Omni-Directional Antenna Repair, Continued

Metallic Whip Broken Into Two Pieces

If a metallic whip antenna becomes broken into two pieces, a splint is the quickest repair you can make. To repair this type of break, perform the steps listed in the table below:

Step	Action
1	Scrape off the paint 3 to 6 inches from the broken ends. Obtain about one foot of copper wire or stripped WD-1.
2	Overlay the cleared ends and wrap them together tightly with the wire. If possible, solder the connection.
3	Place a dry stick, pole, or branch on each side of the break and wrap the splint tightly with WD-1, tape, rope or whatever is available.

If everything else is working right, you're ready to communicate.

Metallic Whip Broken Into Two Pieces Diagram

The steps to repair a broken metallic whip are identified in the diagram below:

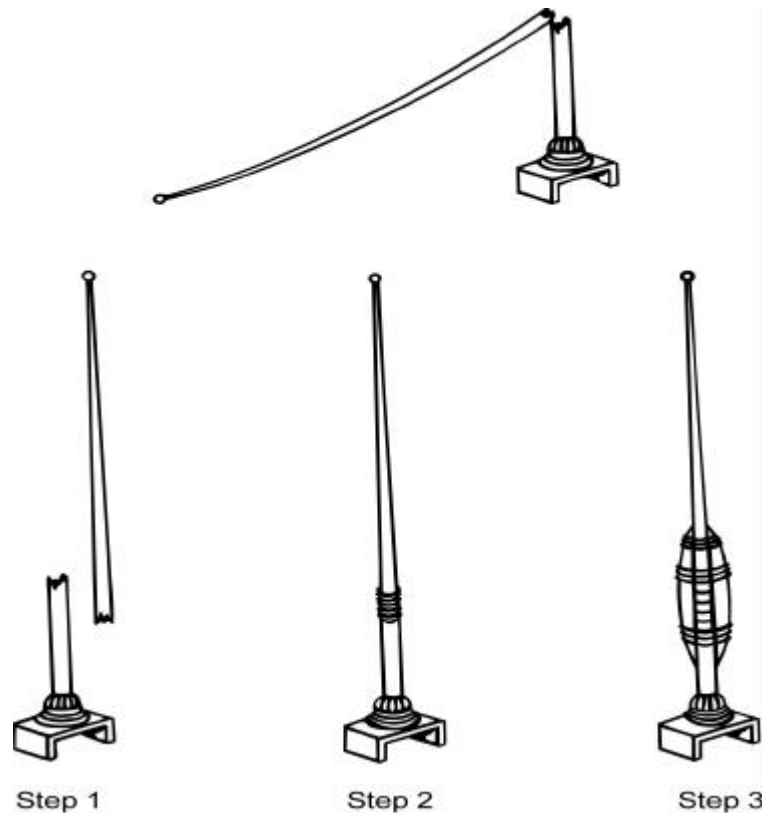

Continued on next page

Omni-Directional Antenna Repair, Continued

Metallic Whip Antenna Lost Parts

If your metallic whip antenna is broken and the upper piece is lost, perform the steps listed in the table below:

Step	Action
1	Obtain a pole 10 feet long, approximately 9 feet of WD-1 and some tape.
2	Scrape off the paint from the top 2 inches of the whip's stub.
3	Wrap 12 inches of bare wire around the scraped portion of the stub. Wrap very tightly, pass it over the top of the stub, and jam it into the hole with a wooden peg and tape if possible.
4	Tie the 10-foot pole tightly to the antenna base and stub.
5	Attach the WD-1 along the length of the pole with tape. Total length of the upright WD-1 and antenna stub should not be more than 9 feet.
6	Trim away any extra wire.

You are now ready to communicate. Move slowly because this mast will not withstand abuse like the original, but will serve you well in an emergency.

Missing Parts Diagram

The steps to repair a metallic whip due to missing parts are identified in the diagram below:

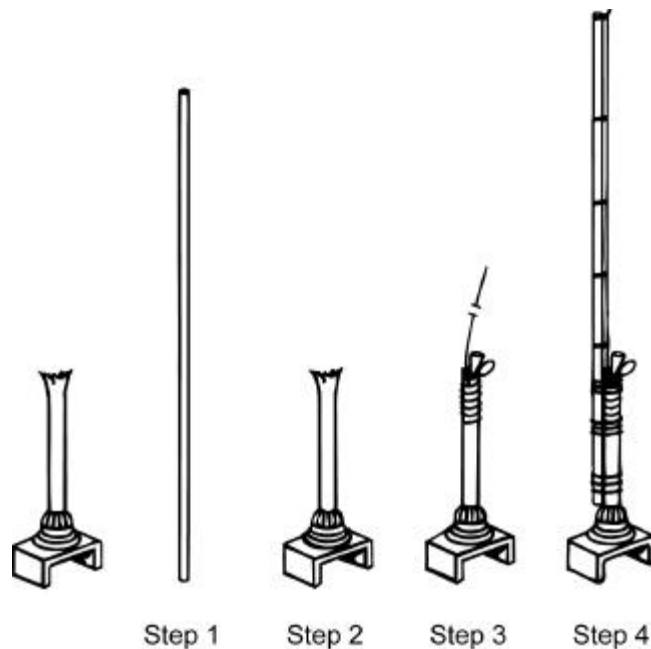





Continued on next page

Omni-Directional Antenna Repair, Continued

Fiberglass Whip Broken Into Two Pieces

If a fiberglass whip antenna breaks into two pieces, you cannot use a splint to fix it like on metal whips. To repair this type of break, perform the steps listed in the table below.

Step	Action
1	<p>Obtain a 15-foot length of coaxial cable. To separate the braided shield from the center conductor, perform the sub-steps listed below:</p> <ul style="list-style-type: none"> • Strip only the outer rubber cover from 5 feet of the cable. With a sharp knife, carefully cut through the outer insulation making sure not to cut into the metal braided shield. <div style="text-align: center; margin: 10px 0;">  </div> • Once the insulation is cut evenly all around, slide it off leaving the braided shield exposed. <div style="text-align: center; margin: 10px 0;">  </div> • Bend the coax in a loop at the point where the outer insulation ends. Holding the coax loop in one hand, carefully separate the metal braided shield from the insulated center conductor with a nail, pencil, or any other pointed object. Gradually work the coax away from the insulated center conductor until enough center conductor is exposed to grasp firmly. <div style="text-align: center; margin: 10px 0;">  </div> • Keeping the loop formed, grasp the center conductor and draw it out of the braided shield. <div style="text-align: center; margin: 10px 0;">  </div>

Continued on next page

Omni-Directional Antenna Repair, Continued

**Fiberglass
Whip Broken
Into Two
Pieces,
continued**

Step	Action
2	Obtain a 10-foot dry pole and lash it to the antenna base.
3	Tape the center conductor to the top half of the pole.
4	Tape the braided shield to the bottom half of the pole.
5	If there's a BNC (twist lock type) connector on the coax, attach it to the radio. If not, strip the end of the center conductor and carefully insert it into the radio's antenna connector. Then attach the braided shield to a screwhead on the radio case.

Remember that this is only a temporary solution, so replace it the first chance you get.

Continued on next page

Omni-Directional Antenna Construction

Preparation

Before constructing any field expedient antennas, it is important to understand the proper handling procedures for WD-1, also known as *slash* or *comm* wire.

Attach the WD-1 to the Connector

Before attaching the WD-1 to the connector of the radio, perform the steps listed in the table below:

Step	Action
1	Loop the wire around the handle of the radio.
2	If your feed line is bare wire, secure the wire to the ground using a stake and insulator to keep the antenna wire from pulling out of the radio's antenna connector.

Insert the WD-1 Into a Connector

Before inserting the bare WD-1 wire end into a connector on an antenna, radio, or any other device, perform the steps listed in the table below:

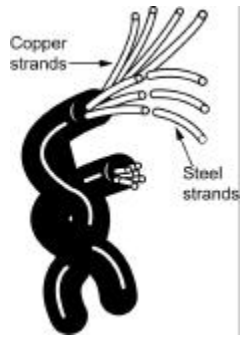
Step	Action
1	Look closely at the bare wire; you will see seven strands. Four strands are flexible copper and give the WD-1 greater conductivity. The other three strands are steel and give the WD-1 its strength. <div style="text-align: center;">  </div>
2	Group the copper strands together and bend them away from the steel strands at a 45-degree angle.
3	Keep the steel strands straight; neatly wrap the copper strands around the steel strands.
4	Trim the exposed wire off at the point where the copper wrapping ends.

You now have a durable wire end that can be inserted into connectors repeatedly without becoming frayed.

Continued on next page

Omni-Directional Antenna Construction, Continued

Quarter-Wave Vertical Antenna

To replace a regular quarter-wave whip antenna, perform the steps listed in the table below:

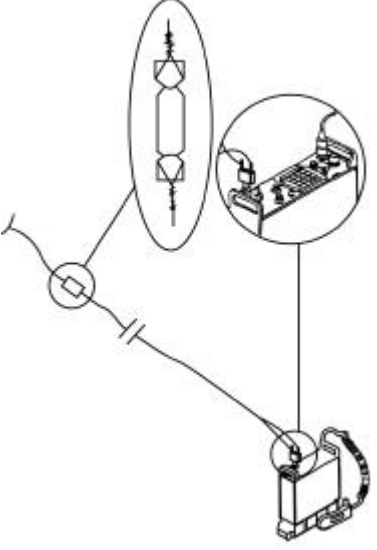
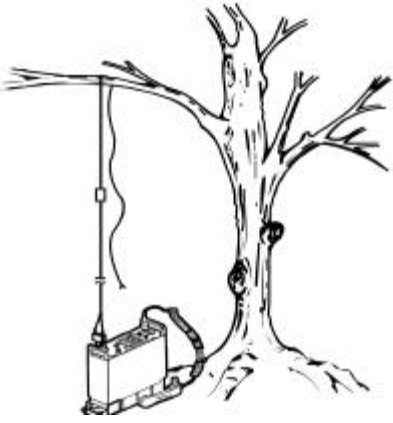
Step	Action
1	Using the quick reference chart or the formula for a quarter wave at the end of this appendix, cut a piece of wire to the required length.
2	Attach an insulator to one end of the wire and attach the other end to the antenna connector on the radio. 
3	Attach a second piece of wire or a piece of rope to the insulator end and throw the wire/rope over a limb. 

Continued on next page

Omni-Directional Antenna Construction, Continued

Quarter-Wave Vertical Antenna, continued

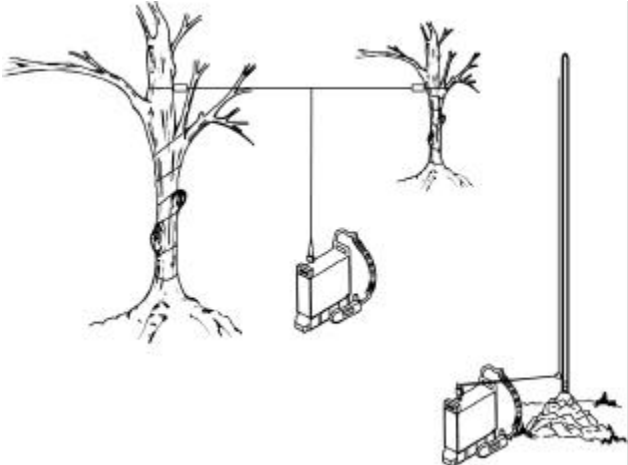

Step	Action
4	<p data-bbox="597 548 1187 579">Pull the antenna up until it is vertical and taut.</p>  <p data-bbox="597 1003 1373 1104">The verticals are constructed the same way, but each has a different means of support. They are all simple and quick to erect.</p> <p data-bbox="597 1136 1401 1314">If you are using insulated wire, be sure to loop the wire around the handle of the radio before attaching it to the antenna connector. If your antenna is made of bare wire, use a stake and insulator to keep the antenna wire from pulling out the antenna connector on the radio.</p> 

Continued on next page

Omni-Directional Antenna Construction, Continued

Tree-Hung Ground Plane

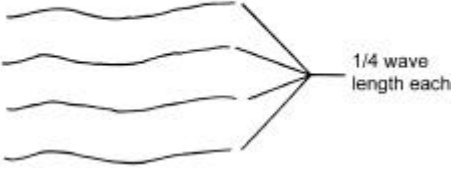
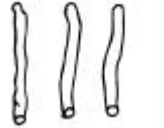

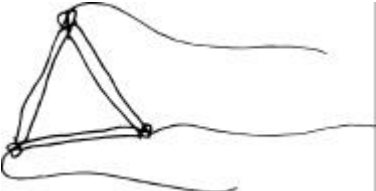
The tree-hung antenna is a good emergency replacement for the OE-254/GRC. This omni-directional, improvised antenna can be used in wooded areas where a tree limb can be used to suspend the antenna. To construct the tree-hung antenna, perform the steps listed in the table below:

Step	Action
1	<ul style="list-style-type: none"> • Use the quick reference chart or the formula for a quarter-wave at the end of this appendix. • Cut a piece of wire to the required length. <p style="text-align: center;">234 % operating frequency = quarter wave antenna</p> 
2	<p>Obtain three slender branches of equal size.</p> 
3	<p>Position the three branches to form a triangle and tie the ends together.</p> 
4	<p>Tie one end of each of the three quarter-wave elements to each corner of the triangle.</p> 

Continued on next page

Omni-Directional Antenna Construction, Continued

Tree-Hung Ground Plane, continued

Step	Action
5	Obtain an insulator and attach the free end of the three elements to it. 
6	Attach the fourth quarter-wave element to the other end of the insulator. 
7	Secure the wire or rope that will be used to suspend the antenna on the opposite end of the fourth element. Attach another insulator to this insulator. 

Continued on next page

Omni-Directional Antenna Construction, Continued

Tree-Hung Ground Plane, continued

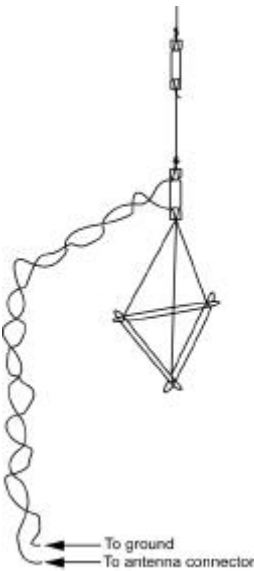
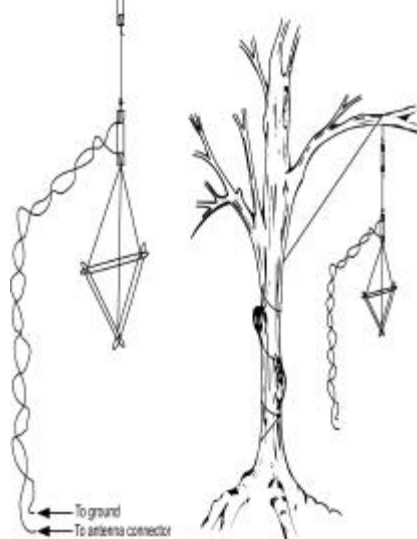

Step	Action
8	<p>Attach the transmission line to the antenna by attaching one end to the three ground plane elements and the other end to the vertical element.</p> 
9	<p>Raise the antenna and tie it off. Then attach the transmission line to the antenna connector on the radio.</p> 

Continued on next page

Omni-Directional Antenna Construction, Continued

Pole Supported Ground Plane

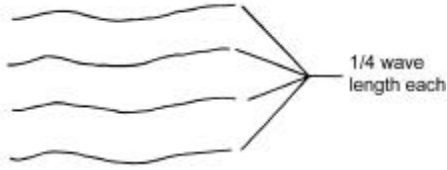

The pole supported ground plane antenna is employed in the same manner as its tree-hung counterpart and can be used in areas where there are no trees to use as supports. To construct a pole supported ground plane, perform the steps listed in the table below:

Step	Action
1	Obtain a large pole. 
2	Compute and cut four wires for a quarter wave. 
3	Attach one quarter-wave element (vertical element) to the pole (the exact location of wire on the pole will depend on antenna length). 

Continued on next page

Omni-Directional Antenna Construction, Continued

Pole Supported Ground Plane, continued

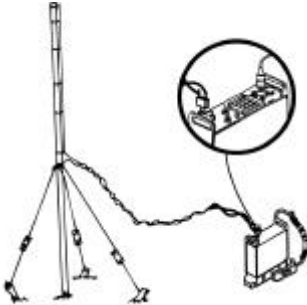
Step	Action
4	Attach the other three quarter-wave elements (ground plane elements) to the pole. Make sure that they are insulated from the vertical element. 
5	Attach insulators to each of the ground plane elements and attach another wire to the opposite end of each insulator. 
6	Raise pole and tie down the three ground plane elements.
7	Connect the transmission line to the vertical and ground plane elements and to the antenna connector on the radio. 

Bi- and Uni-Directional Antenna Construction

Half-Wave Dipole

The half-wave dipole, also known as doublet antenna, is a highly effective bi-directional antenna. It is normally used in the HF range, but can also be used effectively with radios that operate within the VHF range. To construct the half-wave dipole antenna, you will need the following items:

- Two supports (trees or poles)
- Three insulators
- A length of wire (both for the antenna and halyards). Rope can also be used for the halyard.

To build this effective antenna, perform the steps listed in the table below:

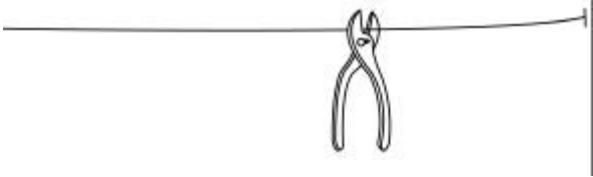
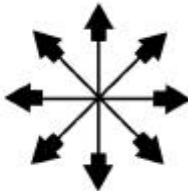
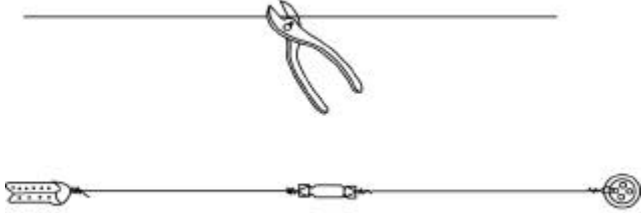
Step	Action
1	<p>Cut the wire to your operating frequency. Use the quick reference chart or formulas at the end of this appendix.</p> 
2	<p>Determine your direction of transmission, keep in mind that this antenna is bi-directional.</p> 
3	<p>Cut the wire in half, placing an insulator on each wire end as well as the center.</p> 

Continued on next page

Bi- and Uni-Directional Antenna Construction, Continued

Half-Wave Dipole, continued

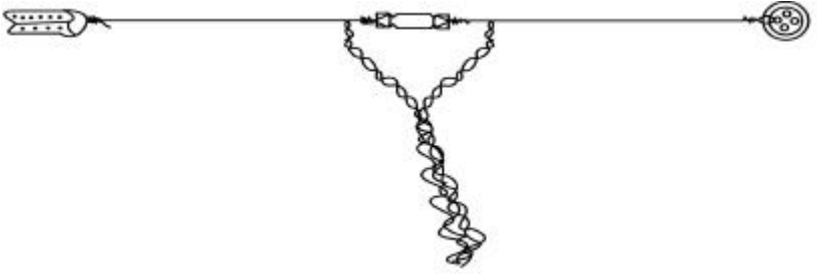
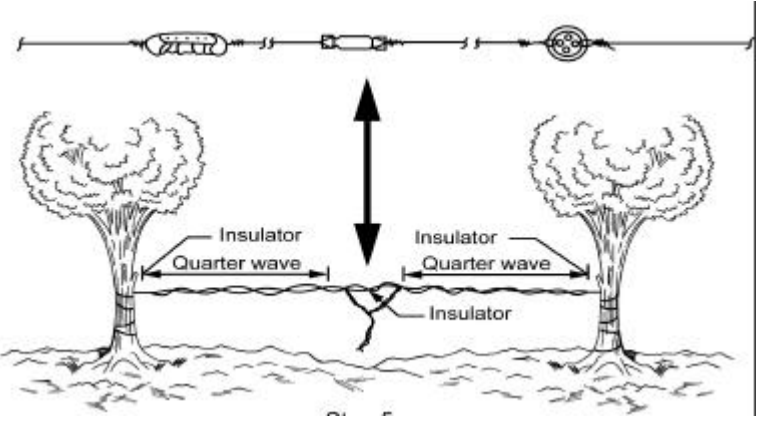

Step	Action
4	Locate and/or erect the two supports. Be certain they are 3 or 4 feet farther apart than the antenna's actual length and broadside to the direction of communications.
5	Attach your transmission line to both sides of the center insulator. Make sure that it is long enough to hang straight to the ground and then to your radio's position. 
6	Tie ropes or wires to the two end insulators. Then use whatever method is easiest, hang the antenna up between the supports, keeping it as taut as possible. 
7	Connect one end of your transmission line to the antenna and the antenna connector on the radio.

Continued on next page

Bi- and Uni-Directional Antenna Construction, Continued

Two-Element Yagi

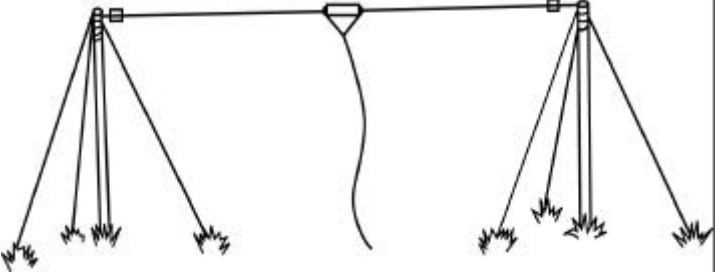
As seen in the diagram below, this configuration consists of a dipole modified by simply adding a reflecting element (a single wire) one quarter-wave length behind the dipole. This reflecting element will help increase the gain and make the antenna more directional. To construct this antenna, perform the steps listed in the table below:

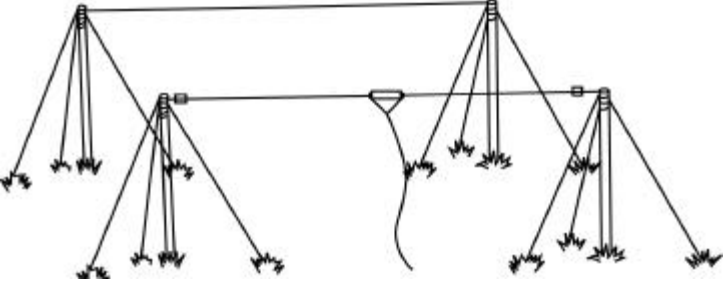
Step	Action
1	Construct a half-wave dipole. 
2	Obtain two supports, either poles or trees.
3	Cut reflecting element. Use the quick reference chart or formulas at the end of this appendix. 
4	Attach the reflecting element to the supports and erect the reflecting element one quarter wavelength behind the dipole antenna. Make sure out-station is forward of the antenna and reflecting elements. 

Continued on next page

Bi- and Uni-Directional Antenna Construction, Continued

Long Wire Antenna

If you need more distance and directivity than your whip antenna will give you, try making a long wire antenna. The overall length of the antenna must be between three to seven wavelengths of the operating frequency depending on the operating area and amount of construction material on hand. With this antenna, you will find that you can communicate over longer distances in either one or two directions. This antenna is bi-directional for high power VHF and HF. For low power VHF, this antenna is uni-directional when terminated with a 500 to 600-ohm, 2-watt carbon resistor. To construct the long wire antenna, perform the steps listed in the table below:

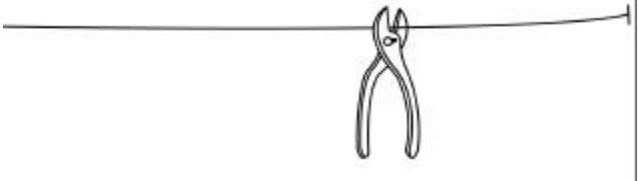
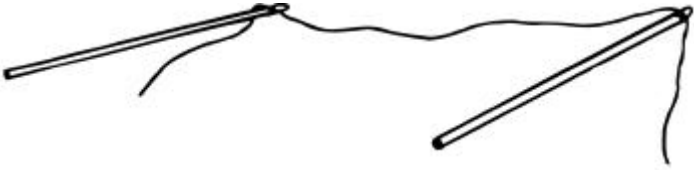
Step	Action
1	<p>Determine the direction of the station you need to reach and line up your antenna. Plan all your work in that direction.</p> 
2	<p>Cut antenna wire to the desired length. Use the quick reference chart or formulas at the end of this appendix.</p> 
3	<p>Select two antenna supports, paying close attention to your operating area. If you are operating in a forested area, trees may be used as supports. If operating in a desert environment, tent or PO-2 poles may be your only choice, so use whatever is available. Keep in mind the higher off the ground you can get your antenna, the better it will perform.</p> 

Continued on next page

Bi- and Uni-Directional Antenna Construction, Continued

Long Wire Antenna, continued

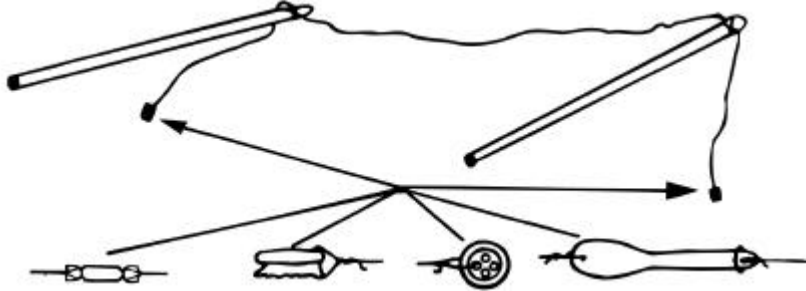
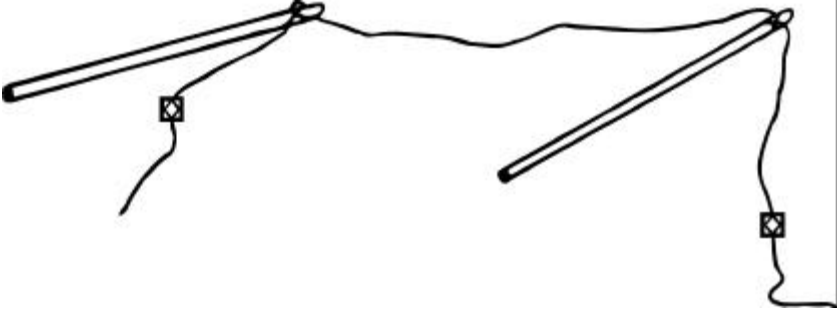
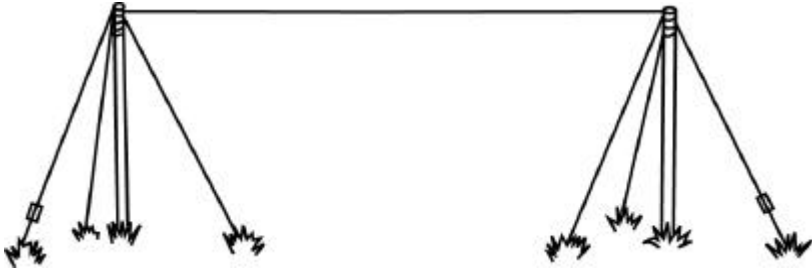
Step	Action
4	Attach the antenna wire to the two supports. 
5	Attach an insulator to each end of the antenna wire. 
6	Connect tie down wires outside the insulators on each end of the antenna wire. 

Continued on next page

Bi- and Uni-Directional Antenna Construction, Continued

Long Wire Antenna, continued

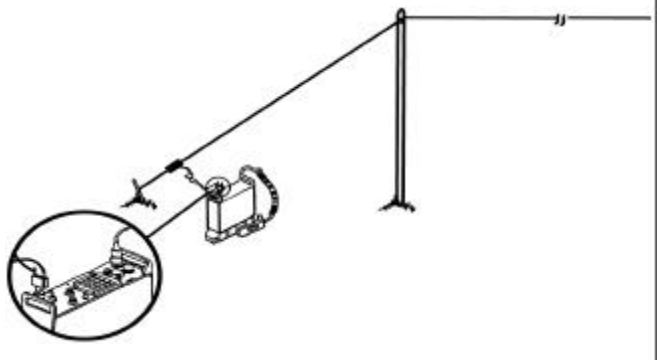
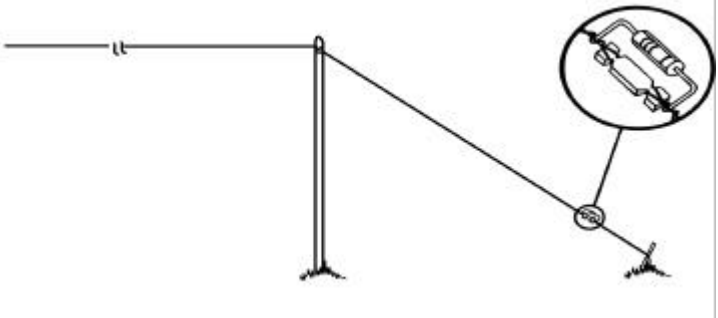
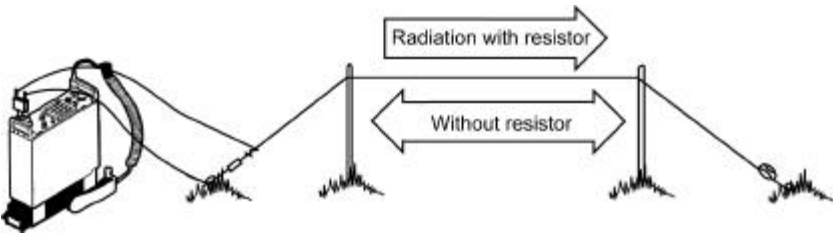
Step	Action
7	<p>Raise and tie down the antenna.</p> 
8	<p>Connect transmission line to the antenna and radio set.</p>  <p>Connect resistor to the far end of antenna, if your antenna is to be uni-directional.</p> 

Continued on next page

Bi- and Uni-Directional Antenna Construction, Continued

Sloping "V" Antenna

The sloping "V" antenna consists of two long wires arranged to form a V shape, which slopes downwards the ground. It is bi-directional to uni-directional and primarily produces sky waves. To construct the sloping "V" antenna, perform the steps listed in the table below:

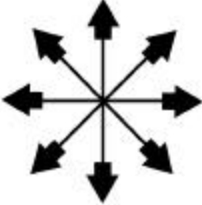
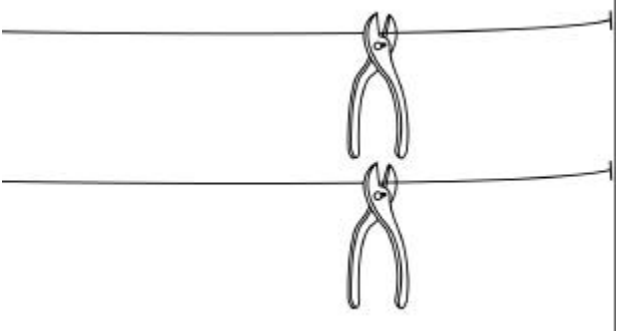
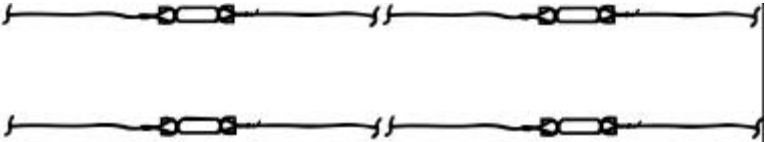
Step	Action
1	<p>Determine the direction of the station you need to reach and line up your antenna. Plan all your work in that direction.</p> 
2	<p>Cut wire for the antenna legs. Leg length is not as critical with this antenna, but should be at least two wavelengths long. Antenna wire should be 10 to 16 gauge copper clad wire.</p> 
3	<p>Connect insulators to each end of the antenna legs. Add tie down wires to the opposite ends of each insulator.</p> 

Continued on next page

Bi- and Uni-Directional Antenna Construction, Continued

Sloping “V” Antenna, continued

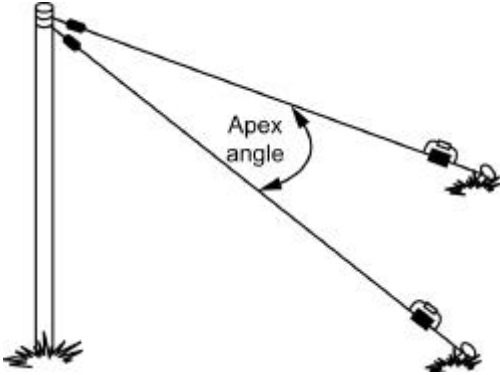
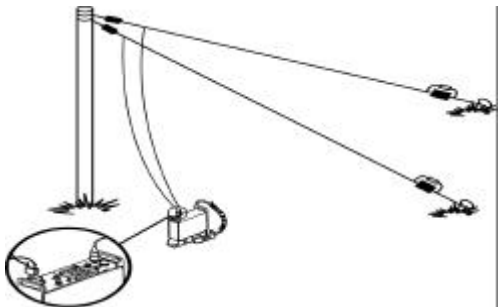
Step	Action																				
4	Select a tree or pole to serve as a mast for the antenna.																				
5	<p>Connect antenna legs to mast. Using the table below, select the apex angle depending upon antenna leg length in wavelengths.</p>  <table border="1" data-bbox="589 1083 1388 1255"> <thead> <tr> <th>Antenna Length (wavelengths)</th> <th>Optimum Apex Angle (degrees)</th> <th>Antenna Length (wavelengths)</th> <th>Optimum Apex Angle (degrees)</th> </tr> </thead> <tbody> <tr> <td>1</td> <td>90</td> <td>6</td> <td>40</td> </tr> <tr> <td>2</td> <td>70</td> <td>8</td> <td>35</td> </tr> <tr> <td>3</td> <td>58</td> <td>9</td> <td>34</td> </tr> <tr> <td>4</td> <td>50</td> <td>10</td> <td>33</td> </tr> </tbody> </table>	Antenna Length (wavelengths)	Optimum Apex Angle (degrees)	Antenna Length (wavelengths)	Optimum Apex Angle (degrees)	1	90	6	40	2	70	8	35	3	58	9	34	4	50	10	33
Antenna Length (wavelengths)	Optimum Apex Angle (degrees)	Antenna Length (wavelengths)	Optimum Apex Angle (degrees)																		
1	90	6	40																		
2	70	8	35																		
3	58	9	34																		
4	50	10	33																		
6	Extend the antenna legs out and stake them down to metal stakes.																				
7	<p>Attach a balanced transmission line to the antenna legs and the radio set.</p> 																				

Continued on next page

Bi- and Uni-Directional Antenna Construction, Continued

Vertical Half-Rhombic

The half-rhombic antenna is a terminated vertical antenna. An unbalanced transmission line, along with a ground or counterpoise increases this antenna's distance and directivity. To construct a vertical half-rhombic antenna, perform the steps listed in the table below:

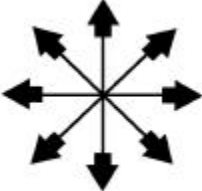
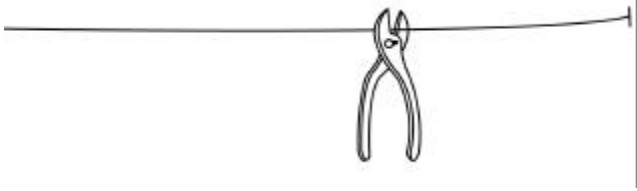
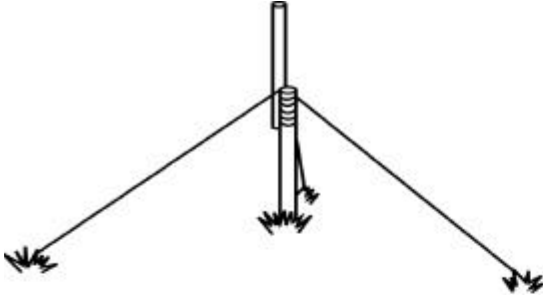
Step	Action
1	<p>Determine the direction of the distant station and line up your antenna. Plan all your work in that direction.</p> 
2	<p>Cut the antenna wire to length, ensuring that each leg of the antenna is at least one wavelength long. At 30 MHz, the leg should be $1\frac{1}{2}$ wavelengths; at 70 MHz, it should be $3\frac{1}{2}$ wavelengths.</p> 
3	<p>Connect an insulator to each end of the antenna wire. Add tie down wires to each insulator.</p>
4	<p>Select a middle support, such as a tree, pole, or a rope suspended between two poles or existing structures. The support should be preferably 30 feet or higher, 20 feet at a minimum.</p> 

Continued on next page

Bi- and Uni-Directional Antenna Construction, Continued

Vertical Half-Rhombic, continued

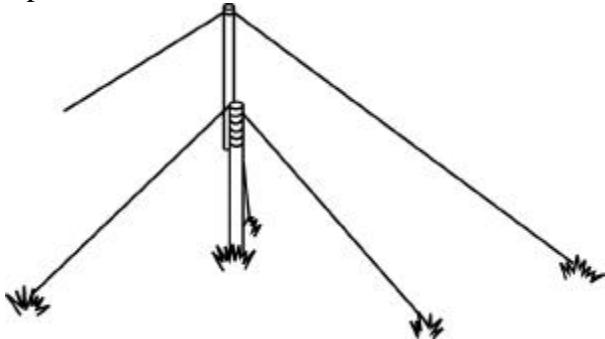
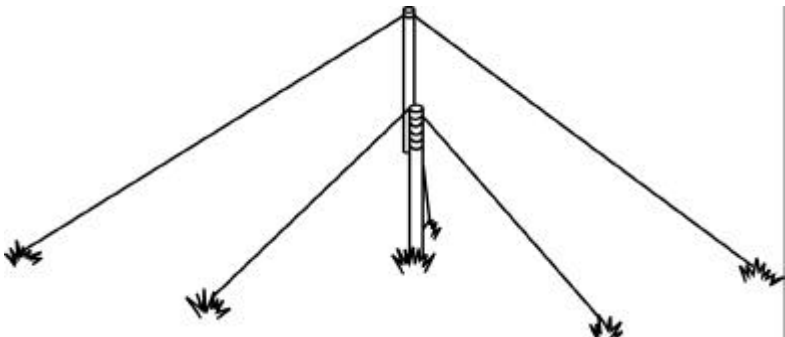
Step	Action
5	<p>Select one element and run it out in the direction of the distant station. Stake this element down with a metal stake.</p> 
6	<p>Connect antenna wire to the support and raise antenna. If you are using a rope as your middle support, drape your antenna wire over the rope.</p> 
7	<p>Extend the other end of the antenna wire until it is tight and stake it down using another metal stake.</p> 

Continued on next page

Bi- and Uni-Directional Antenna Construction, Continued

Vertical Half-Rhombic, continued

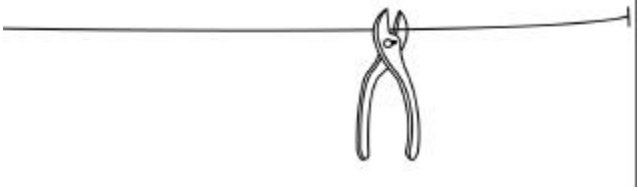
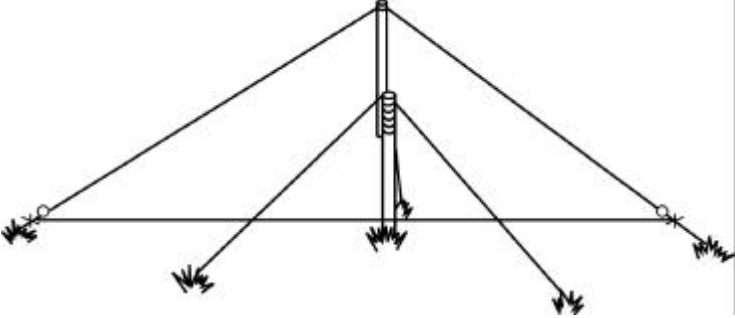
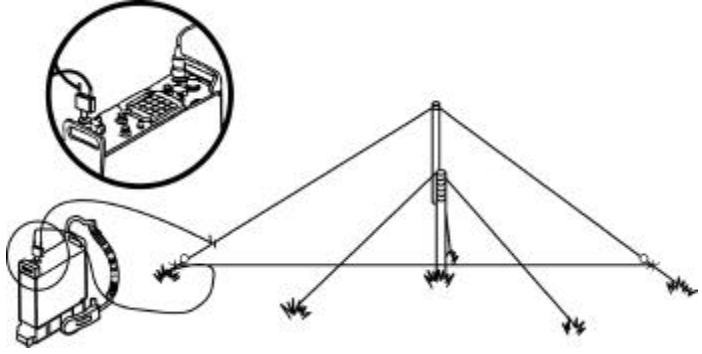
Step	Action
8	<p>Measure and cut another piece of wire to be used as a counterpoise. This piece of wire should be long enough to span the distance between the two insulators.</p> 
9	<p>Attach one end of the counterpoise between the ground stake and antenna insulators, then to the other end of the antenna, keep it a foot off the ground. Make sure the counterpoise is connected to the support material between the ground stake and antenna insulator, not to the antenna wire.</p> 
10	<p>Attach a transmission line to the antenna and to the radio.</p> 

Continued on next page

Bi- and Uni-Directional Antenna Construction, Continued

Vertical Half-Rhombic, continued

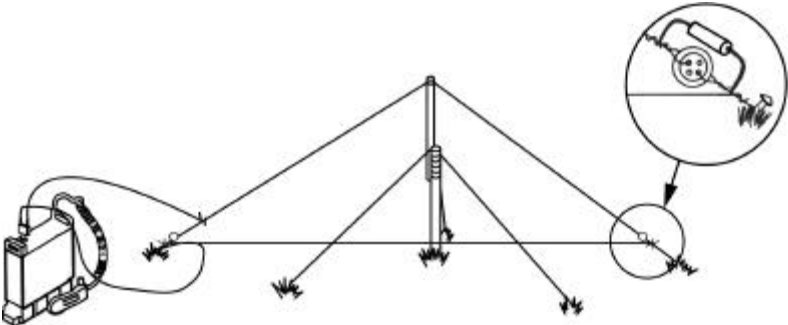
Step	Action
11	<p data-bbox="573 527 1357 632">To make this antenna more directional, connect a 500-ohm, 2-watt carbon resistor across the insulators at the end farthest from the intended receiver.</p>  <p>The diagram shows a vertical half-rhombic antenna structure. It consists of a central vertical mast supported by a horizontal base. Two diagonal wires extend from the top of the mast to the ends of the horizontal base. A third wire runs horizontally from the top of the mast to the right end of the horizontal base. A receiver is connected to the left end of the horizontal base. A resistor is connected across the two insulators at the right end of the horizontal base. A circular inset provides a magnified view of the resistor connection, showing the resistor's leads connected to the insulators.</p>

Formulas and Quick Reference Charts

Formulas

A quick reference chart is listed in the table below:

To Figure	Action
A Quarter Wavelength Antenna in Feet	Divide 234 (constant) by your operating frequency in MHz. Example: 234 divided by 44.8 = 5.22 feet or 5' 3"
A Half Wavelength Antenna in Feet	Divide 468 (constant) by your operating frequency in MHz. Example: 468 divided by 56 = 8.36 feet or 8' 4"
A Full Wavelength Antenna in Feet	Divide 936 (constant) by your operating frequency in MHz. Example: 936 divided by 45=20.8 feet or 20' 10"
A Multiple Wavelength Antenna in Feet	Divide 936 (constant) by operating frequency in MHz, then multiply the resultant by the desired antenna wavelength. Example: 936 divided by 45 = 20.8, for an antenna 4 wavelengths long, 20.8 multiplied by 4 = 83.2 or 83' 3"
Convert Feet to Meters	Multiply by .3048 (constant). Example: 110 feet times .3048 = 33.5 meters
Convert Meters to Feet	Multiply by 3.28 (constant). Example: 100 meters times 3.28 = 328

Continued on next page

Formulas and Quick Reference Charts, Continued

High Frequency (HF) Use the table below to determine the length of the antenna for high frequencies:

High Frequency (HF)			
Operating Frequency in MHz	Quarter Wave	Half Wave	Full Wave
2	117'	234'	468'
3	78'	156'	312'
4	58' 6"	117'	234'
5	46' 9"	93' 7"	187' 4"
6	39'	78'	156'
7	33' 5"	66' 10"	133' 8"
8	29' 3"	58' 6"	117'
9	26'	52'	104'
10	23' 5"	46' 10"	93' 8'
11	21' 3"	42' 6"	85'
12	19' 6"	39'	78'
13	18'	36'	72'
14	16' 9"	33' 5"	66' 10"
15	15' 7"	31' 2"	62' 4"
16	14' 7"	29' 2"	58' 4"
17	13' 9"	27' 6"	55'
18	13'	26'	52'

Continued on next page

Formulas and Quick Reference Charts, Continued

Very High Frequency (VHF)

Use the table below to determine the length of the antenna for very high frequencies:

Very High Frequency (VHF)			
Operating Frequency in MHz	Quarter Wave	Half Wave	Full Wave
30	7' 10"	15' 7"	31' 2"
33	7' 1"	14' 2"	28' 4"
35	6' 9"	13' 5"	26' 10"
37	6' 4"	12' 7"	25' 2"
40	5' 10"	11' 8"	23' 4"
43	5' 5"	10' 1"	21' 8"
45	5' 3"	10' 5"	20' 10"
48	4' 10"	9' 8"	19' 4"
50	4' 9"	9' 5"	18' 10"
55	4' 3"	8' 6"	17'
57	4' 1"	8' 2"	16' 4"
60	3' 11"	7' 10"	15' 8"
65	3' 7"	7' 2"	14' 4"
68	3' 5"	6' 10"	13' 8"
70	3' 4"	6' 7"	13' 2"
75	3' 1"	6' 2"	12' 4"
80	3'	5' 11"	11' 10"

Field Expedient Antenna Supplies

Field Tool Kit If you are going to be constructing field expedient antennas on a regular basis, it is a good idea to build a field expedient tool kit. The tools and equipment you will need can be scrounged or purchased through the Marine Corps supply system or local electronic hobby stores. Keep the kit in a standard issue canvas bag or ammunition can for safekeeping and easy deployment. The kit should be inventoried and cleaned and lubricated on the same schedule as most issued toolkits.

Contents Your toolkit should contain the items listed in the table below:

Quantity	Description
1 each	Screwdriver with assorted tips
1 each	Multi-tool, such as Leatherman®
2 each	6" Crescent® wrench
1 each	Miniature "AA" size flashlight
2 each	Spare "AA" batteries
1 each	Spare flashlight bulb
1 each	Small button-type compass
1 each	Small wire brush
3 sheets	Assorted sandpaper
1 each	Small all purpose brush
1 each	Pencil eraser
2 rolls	Electrical tape
30 feet	Antenna wire
4 feet	Insulated 18 gauge wire
15 feet	Coaxial line (RG-58)
4 each	BNC connector
4 each	BNC to Banana type adapter
1 each	Hand drill
1 each	Small butane-powered soldering torch
1 roll	Solder
1 box	Assorted solder lugs
1 box	Assorted (crimp-type) wire ends
1 box	Assorted metal screws
1 box	Assorted bolts
1 box	Assorted nuts
1 box	Assorted washers
1 box	Nails
1 each	Hammer
100 feet	Nylon twine or "550" cord
6 each	Insulators
4 each	Hose clamps
6 each	Alligator clips
1 each	Broadband balun

Continued on next page

Field Expedient Antenna Supplies, Continued

Emergency Supplies

If you find yourself in a situation where you need to construct a field expedient antenna and do not have the proper supplies, you can improvise by making the following substitutions:

Original Issue	Field Issue
Antenna wire	Barbed wire, electrical cord
Antenna mast	Trees, sticks, telephone poles
Antenna guy ropes	Cloth belts, slings, boot laces
Guy stakes	Rocks, vehicles, trees
Insulators	MRE spoons, buttons, rags

APPENDIX B

JOINT SPECTRUM CENTER (JSC)

Overview

Introduction

The effectiveness of the command and control, and the ability of the communications system to respond to a rapidly changing tactical situation will determine the degree of success on the modern battlefield. Effective communications systems require accurate and timely communications electronics engineering analysis support for operational and combat units. To meet this demand, the Joint Chiefs of Staff has established the Joint Spectrum Center (JSC). Based in Annapolis, Maryland, JSC has served to ensure the DOD's effective use of the electromagnetic spectrum in support of national security and military objectives since 1960. JSC provides operational support by assisting Marine Corps units in identifying the anticipated physical and electronic environment and then providing analysis support assessing the effect of the environment on the unit's ability to accomplish its mission.

Scope

This appendix describes the various analytical capabilities and the input data required for Marine Corps communications electronics engineering and electro-magnetic compatibility support through JSC.

Note: Appendix B is professional reference material designed to enhance your abilities *only*; this information is not tested in this course.

In This Appendix

This appendix contains the following topics:

Topic	See Page
Overview	B-1
Point-to-Point Multichannel Predictions	B-2
Received Signal Level (RSL) Coverage Overlays	B-4
Line-of-Sight (LOS) Coverage Overlays	B-7
High Frequency (HF) Sky Wave Propagation Predictions	B-10
High Frequency (HF) Ground Wave Propagation Predictions	B-11
Three-Dimensional Terrain Plots	B-12
Terrain Horizon Plots	B-13
How to Contact the JSC	B-14

Point-to-Point Multichannel Predictions

Description The point-to-point multichannel circuit reliability analyses predict short-term reliabilities for wideband multichannel circuits. Reliability is predicted by determining the terrain-dependent path loss, received signal level, and estimated fade margin. Data provided in the prediction includes antenna horizon angle, true and magnetic azimuths, path distance, reliability percentages, and propagation modes.

Terrain Profile For point-to-point reliability analyses, a profile of the terrain between two points can also be beneficial. The diagram below shows such a terrain profile.

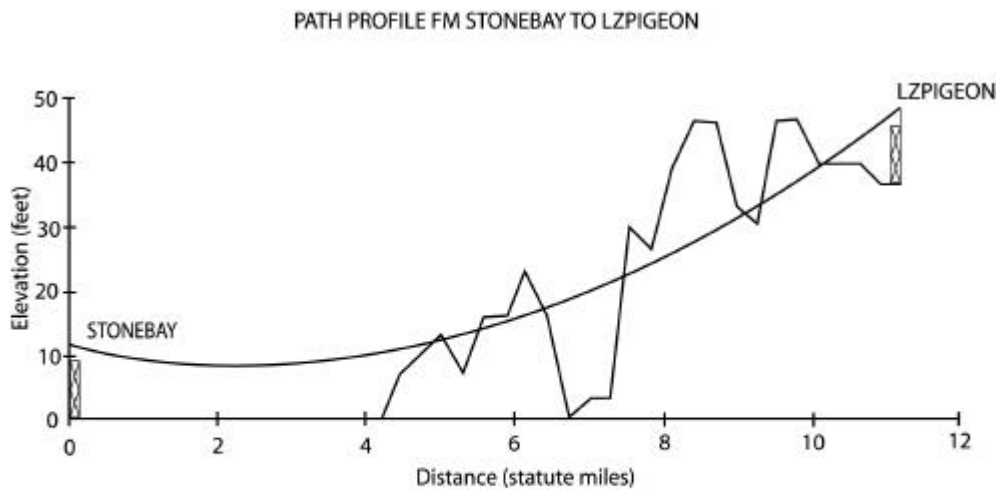

Site STONEBAY: 34 35 32 N 077 25 34 W Elevation: 0 feet Antenna Height: 12 feet
Site LZPIGEON: 34 39 54 N 077 15 01 W Elevation: 36 feet Antenna Height: 12 feet
Link Distance: 11.2 statute miles Bearing from STONEBAY to LZPIGEON: 63.35 degrees
Frequency: 4.7 GHz Minimum Clearance: -18.86 feet at 8.39 statute miles from Site STONEBAY
Clearance (in number of first Fresnel Zones): .39 at 8.39 statute miles from Site STONEBAY

Continued on next page

Point-to-Point Multichannel Predictions, Continued

Required Information

The following information is required for point-to-point multichannel reliability predictions:

- Transmitter and receiver site locations, latitude/longitude, DDMSS
 - Equipment nomenclature and model number
 - Antenna gain (dBi), if known
 - Type of antennas, transmitter and receiver
 - Required delivery date
 - Organization and mailing address
 - Phone numbers (voice and fax)
 - Point of contact
-

Received Signal Level (RSL) Coverage Overlays

Description

Radio RSL coverage overlays are used to depict the approximate signal levels around a transmitter site taking into account such circuit parameters as transmitter power, transmit and receive antenna gains, and terrain topographic elevations data. This type of analysis is used to predict the area of reliable communications for tactical equipment and to determine the susceptibility of friendly equipment to enemy intercept/jamming. The RSL coverage overlays are normally provided at a map scale of 1:250,000, but may be varied to meet the user's needs. The coverage predictions can represent one transmitter, multiple transmitters, or the combined/composite coverage of several transmitters. The overlays can represent ground-to-ground, air-to-ground, and ground-to-air coverage.

Single Site Coverage Overlay

The diagram below is an example of a received signal level coverage overlay for a single site. The tic marks on the contour lines point to the area of lesser signal strength.

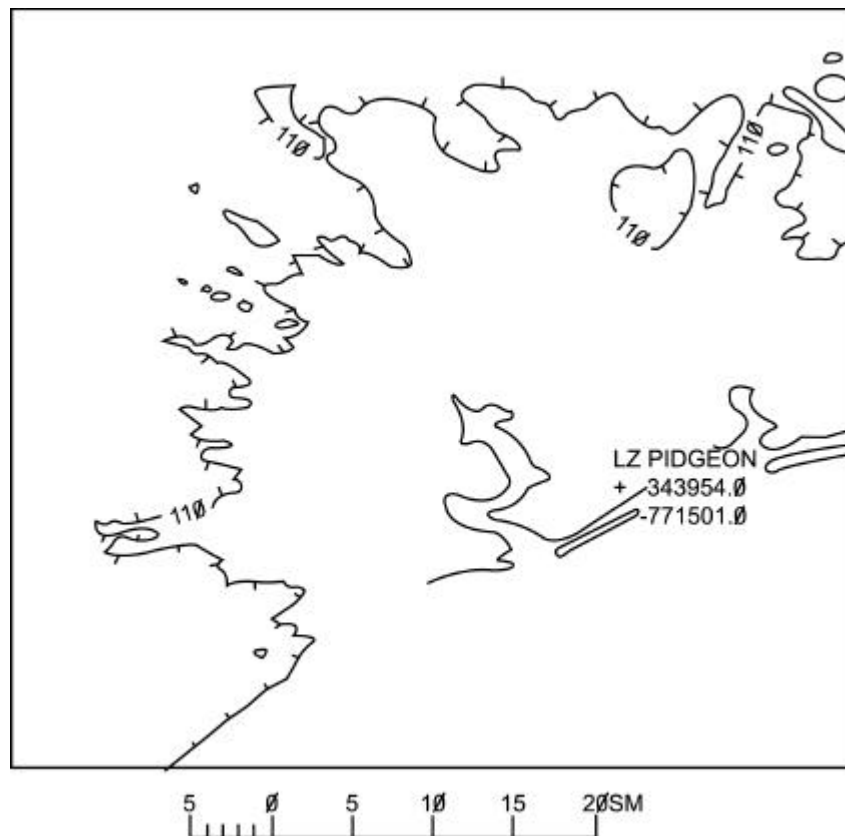

Continued on next page

Received Signal Level (RSL) Coverage Overlays, Continued

Multiple Site Coverage Overlay

The diagram below is an example of a received signal level coverage overlay for multiple sites. The tic marks on the contour lines point to the area of lesser signal strength.

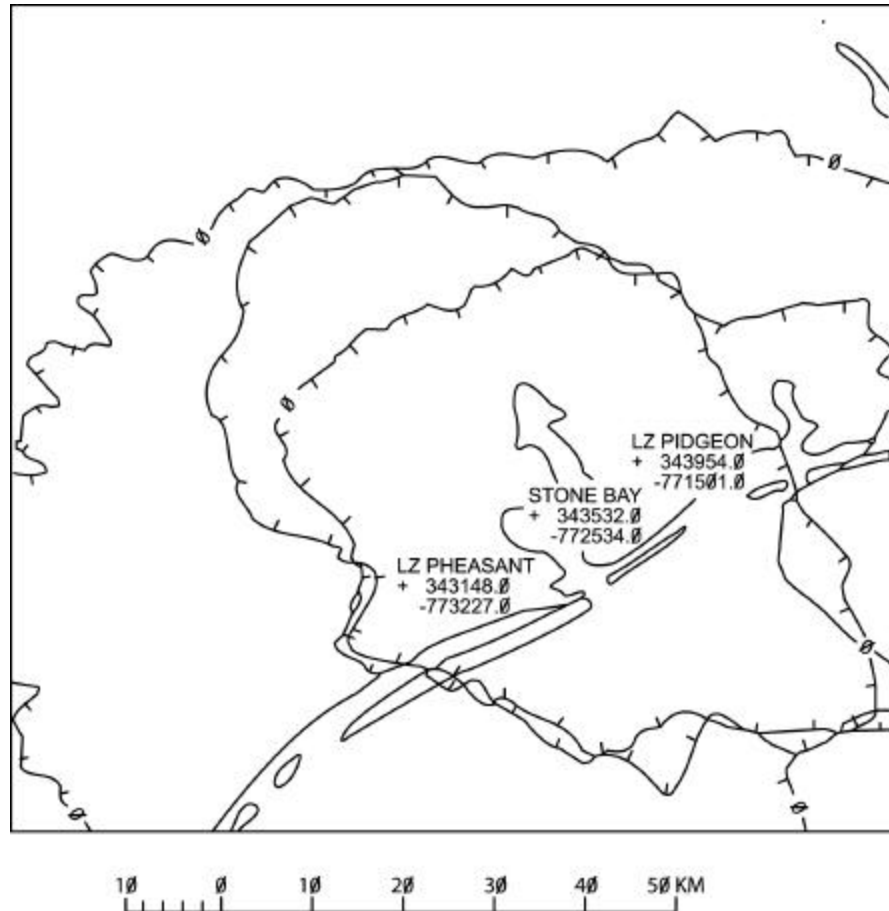

Continued on next page

Received Signal Level (RSL) Coverage Overlays, Continued

Required Information

The following information is required for RSL coverage overlays:

- Transmitter site location, latitude/longitude, DDMMSS
 - Transmitter output power
 - Transmitter and receiver antenna type
 - Antennas gain, if known
 - Antenna height above ground
 - Equipment type and model number
 - Organization and mailing address
 - Phone numbers (voice and fax)
 - Point of contact
-

Line-of-Sight (LOS) Coverage Overlays

Description Light-of-sight (LOS) coverage overlays depict LOS around radio and radar sites. This analysis is especially useful for choosing relay/retransmission sites for tactical radios and microwave terminal locations, and for positioning other LOS communication equipment. Additionally, radar LOS coverage overlays enable easy assessment of site suitability with respect to the detection of incoming targets.

LOS Overlay The diagram below is an example of a radio LOS coverage overlay for a tactical transmitter. The tic marks on the contour lines point to the areas that are within the transmitter's line-of-sight.

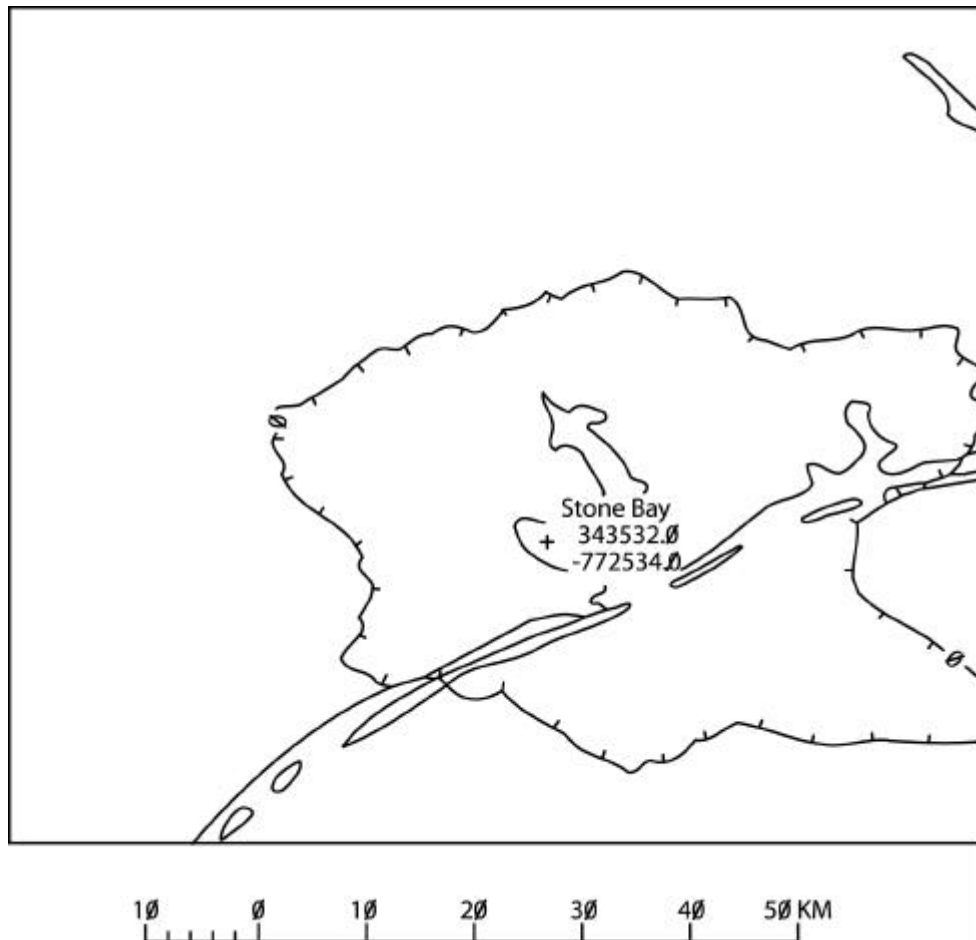

Continued on next page

Line-of-Sight (LOS) Coverage Overlays, Continued

Radar Overlay The diagram below is an example of a LOS coverage overlay for radar equipment. The coverage contours shown depict the radar target acquisition distance for targets at various altitudes. Target altitudes may be specified above mean sea level (MSL) or above ground level (AGL). In this example, target altitudes of 250 to 8,000 feet above MSL are specified.

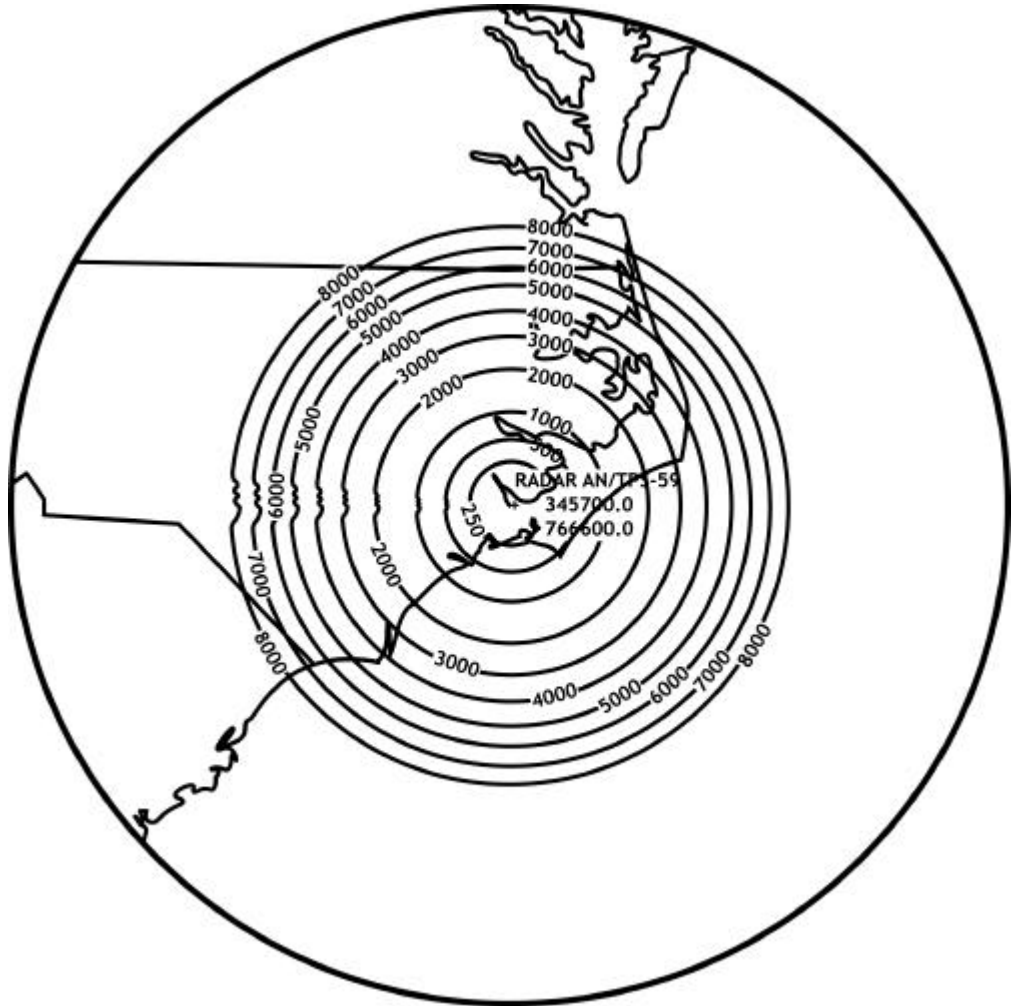

Continued on next page

Line-of-Sight (LOS) Coverage Overlays, Continued

Required Information

The following information is required for LOS coverage overlays:

- Transmitter site location, latitude/longitude, DDMMSS
 - Transmitter antenna height above ground
 - Coverage radius
 - Target altitudes (radar LOS only)
 - Receiver antenna height above ground (radio LOS only)
 - Required delivery date
 - Organization and mailing address
 - Phone numbers (voice and fax)
 - Point of contact
-

High Frequency (HF) Sky Wave Propagation Predictions

Description High frequency (HF) sky wave propagation predictions describe the usable frequencies and the predicted circuit reliability between a transmitter and receiver site. The most common formats available for JSC HF predictions are

- Method 28
 - Method 31
 - Method 34
-

Method 28 Method 28 provides predictions for maximum usable frequency (MUF), frequency of optimum transmission (FOT), and lowest usable frequency (LUF) for HF sky wave path between a transmitter and receiver site for a 24-hour period for a specific month.

Method 31 Method 31 provides the frequency of optimum transmission (FOT), take-off angle (ANG), and the predicted reliability (REL) (in percent) of selected frequencies between a transmitter and receiver site for a 24-hour period for a specific month.

Method 34 Method 34 shows the FOT, ANG, and REL between a transmitter site and multiple receiver sites for a 24-hour period for a specific month.

Required Information The following information is required for HF propagation predictions:

- Transmitter site location, latitude/longitude, DDMMSS
 - Receiver site location(s)/latitude(s)/longitude(s), DDMMSS
 - Transmitter output power
 - Type of antenna(s)
 - Emission designator(s)
 - Man-made noise at the receiver site (industrial, residential, rural, remote)
 - Day, month, and year of the start and end of transmission
 - Required delivery date
 - Organization and mailing address
 - Phone numbers (voice and fax)
 - Point of contact
-

High Frequency (HF) Ground Wave Propagation Predictions

Description

HF ground wave propagation predictions provide the predicted range over which a ground wave signal is expected to be reliably received during a 24-hour period. These calculations are based on the path distance, transmitter power, emission type, antenna heights, and ground conductivity along the communications path. Effective month of the predictions, transmitter power, type antennas, frequency values, path loss, and distances are depicted in the output. The calculations do not consider the effects of atmospheric phenomena, detailed topography, or foliage. Additionally, the path can be incremented when transmission is over land and water. Incrementing allows the analyst to define the variations in ground constants for the different types of soil.

Required Information

The following information is required for HF propagation predictions:

- Transmitter site location, latitude/longitude, DDMMSS
 - Desired radius around transmitter location (KM or SM)
 - Transmitter output power
 - Type of antenna(s)
 - Emission designator(s)
 - Man-made noise at the receiver site (industrial, residential, rural, remote)
 - Day, month, and year of the start and end of transmission
 - Required delivery date
 - Organization and mailing address
 - Phone numbers (voice and fax)
 - Point of contact
-

Three-Dimensional Terrain Plots

Description

Three-dimensional terrain plots display the topographical data for a specific area in the form of a three-dimensional graph. These plots are useful for a quick identification of possible relay/retransmission sites and for map studies of exercise or contingency areas. The plots are produced in several colors, one for each elevation threshold and can be plotted on 36" by 36" paper. The diagram below provides an example of a three-dimensional terrain plot.

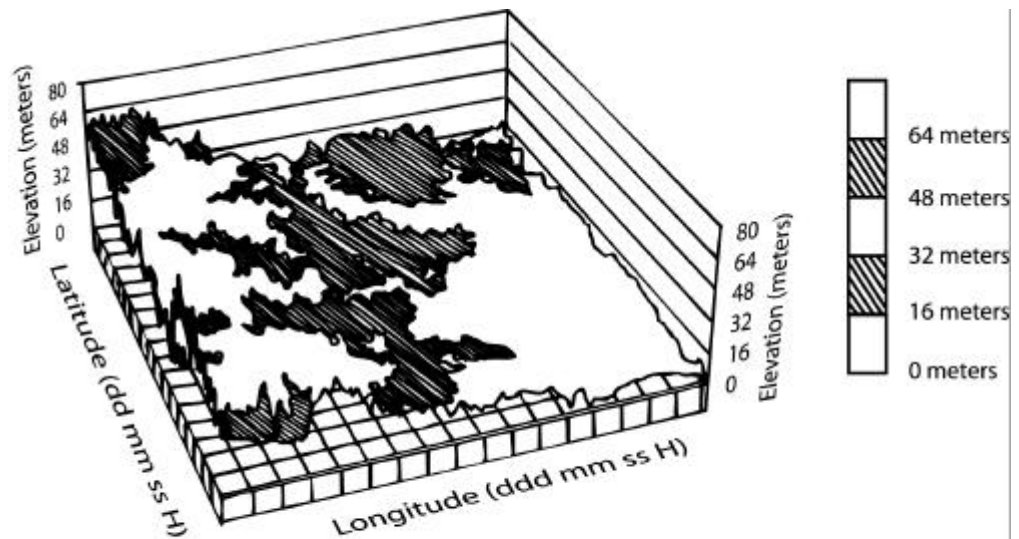

Required Information

The following information is required for a three-dimensional terrain plot:

- Latitude/longitude, DDMMSS of the four corners of the area of interest
 - Required delivery date
 - Organization and mailing address
 - Phone numbers (voice and fax)
 - Point of contact
-

Terrain Horizon Plots

Description

The terrain horizon plot illustrates the terrain contour information around a specified site location. These plots can be used to graphically represent the radio or visual horizon around a site. To meet their requirements, the users may vary the scan angle (azimuth) and horizon angle (elevation). The diagram below provides an example of a terrain horizon plot.

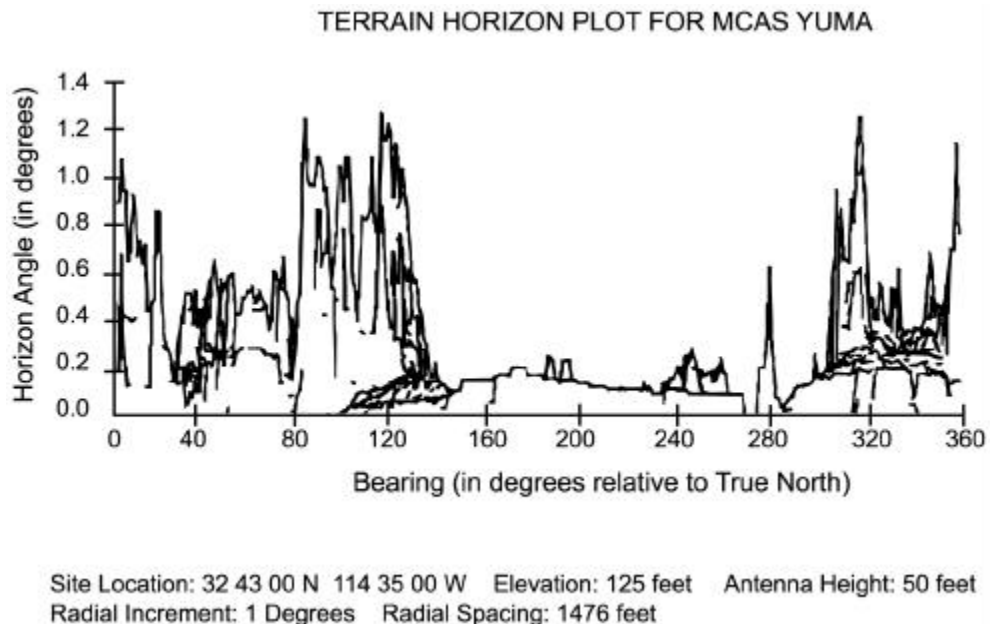

Required Information

The following information is required for a terrain horizon plot:

- Site location latitude/longitude, DDMSS
- Antenna height
- Initial scan angle (degree)
- End scan angle (degree)
- Lowest horizon angle (degree)
- Highest horizon angle (degree)
- Horizon distance (statute miles)
- Required delivery date
- Organization and mailing address
- Phone numbers (voice and fax)
- Point of contact

How to Contact the JSC

Contact Information

Contact the Joint Spectrum Center, J3 for support. Points of contact are as follows:

- DSN 281-2814/2328/9815, normal duty hours
 - COMM 401-293-2814/2328/9815, normal duty hours
 - STU III & Secure FAX DSN 281-2452, normal duty hours
 - FAX DSN 281-3763/COMM 410-293-3763, 24 hours
 - After normal duty hours: 410-991-3143, PIN 419-8623 (pager)
 - Message address: JSC ANNAPOLIS MD//J3//
 - E-mail: operations@jsc.mil
 - SIPRNET: operations@jsc.js.smil.mil
-

More Information

For more information concerning the mission of the JSC, visit their website at <http://www.jsc.mil/>

ANTENNA CONSTRUCTION AND PROPAGATION OF RADIO WAVES

REVIEW LESSON EXAMINATION

Review Lesson

Introduction The purpose of the review lesson is to prepare you for your final examination. We recommend that you try to complete your review lesson without referring to the text, but for those items (questions) you are unsure of, restudy the text. When you have finished your review lesson and are satisfied with your responses, check your responses against the answers provided at the end of this review lesson examination.

Directions Select the ONE answer that BEST completes the statement or answers the item. For multiple-choice items circle your response. For matching items place the letter of your response in the space provided.

Item 1 What part of a radio set is used for sending radio signals?

- a. Demodulator
- b. Transmitter
- c. Receiver
- d. Amplifier

Item 2 What component of a radio set extracts the desired electro-magnetic waves from the air, amplifying them and removing the intelligence in the demodulation process?

- a. Antenna
- b. Receiver
- c. Transmitter
- d. Power converter

Continued on next page

Review Lesson, Continued

Item 3 What device is used for transmitting and receiving radio waves?

- a. Receiver
 - b. Transmitter
 - c. Antenna
 - d. Demodulator
-

Item 4 What provides operating voltage to a radio set?

- a. Power supply
 - b. Direct current
 - c. Alternating current
 - d. Carrier wave
-

Item 5 Electro-magnetic energy radiated from an antenna is known as _____ waves.

- a. sky
 - b. ground
 - c. magnetic
 - d. radio
-

Item 6 The number of complete cycles that occurs in one second determines the

- a. frequency of a radio wave.
 - b. amount of energy available in a power supply.
 - c. type of power supply needed to operate a radio set.
 - d. speed at which electro-magnetic energy travels through space.
-

Item 7 What is the formula for finding the length (in meters) of a radio wave when the frequency is known?

- a. 3,000 divided by the frequency
 - b. 30,000 divided by the frequency
 - c. 300,000 divided by the frequency
 - d. 300,000,000 divided by the frequency
-

Continued on next page

Review Lesson, Continued

- Item 8** What type of wave acts as a medium for the transmission of information signals?
- a. Carrier
 - b. Frequency
 - c. Transmission
 - d. Received
-

- Item 9** The process that varies or modifies either the frequency or amplitude of the carrier waveform is known as the
- a. critical frequency.
 - b. transmission.
 - c. modulation.
 - d. carrier wave converter.
-

- Item 10** What type of modulation varies the RF power output of a transmitter?
- a. FM
 - b. FSK
 - c. SSB
 - d. AM
-

- Item 11** What is the process called that varies the frequency of a carrier wave in proportion to the amplitude of the modulating signal?
- a. FM
 - b. FSK
 - c. AM
 - d. SSB
-

Continued on next page

Review Lesson, Continued

- Item 12** Digital modulation is accomplished by shifting the _____ of the carrier wave.
- a. data
 - b. amplitude
 - c. frequency
 - d. phase
-

- Item 13** A gaseous mass that envelops the earth describes the
- a. autmosphere.
 - b. source of ionization.
 - c. atmosphere.
 - d. regions in outer space.
-

- Item 14** Name the three regions of the atmosphere in order of their relative heights.
- a. Troposphere, ionosphere, and stratosphere
 - b. Stratosphere, troposphere, and ionosphere
 - c. Troposphere, stratosphere, and ionosphere
 - d. Ionosphere, troposphere, and stratosphere
-

- Item 15** Which region of the ionosphere has little effect in bending the paths of high frequency radio waves?
- a. F₁
 - b. F₂
 - c. E
 - d. D
-

- Item 16** Which region of the ionosphere is ionized at all hours of day and night?
- a. D
 - b. E
 - c. F
 - d. G
-

Continued on next page

Review Lesson, Continued

- Item 17** The chief factor that controls long distance communication is the _____ of the ionized layer.
- a. location
 - b. density
 - c. size
 - d. color
-

- Item 18** Which two layers of the ionosphere are the most highly ionized?
- a. D and E
 - b. D and F
 - c. E and F
 - d. D and F₂
-

- Item 19** The highest frequency at which waves sent vertically upward are reflected directly back to earth defines
- a. the highest frequency of transmission.
 - b. modes of transmission.
 - c. critical frequency.
 - d. interference frequency.
-

- Item 20** A ground wave is a radio wave that travels
- a. skyward.
 - b. skyward and near the earth's surface.
 - c. near the skip zone.
 - d. near the earth's surface.
-

- Item 21** The direct, ground-reflected, and surface waves are all components of the _____ wave.
- a. sky
 - b. single hop
 - c. tropospheric
 - d. ground
-

Continued on next page

Review Lesson, Continued

Item 22

Ground wave propagation is extremely useful for communication at

- a. any frequency.
 - b. low frequencies.
 - c. high frequencies.
 - d. super-high frequencies.
-

Item 23

What type of radio wave depends on the ionosphere to provide signal paths between transmitter and receiver?

- a. Sky
 - b. Ground
 - c. Direct
 - d. Ground reflected
-

Item 24

An area bounded by the outer edge of the usable ground wave propagation and the point nearest the antenna at which the sky wave returns to earth is known as the

- a. skip area.
 - b. skip zone.
 - c. unusable zone.
 - d. skip distance.
-

Item 25

The frequencies that return to earth from a fixed angle of departure are known as the MUF. The MUF used in predicting the operating frequencies refers to the

- a. maximum transmission distance possible for a given operating frequency.
 - b. minimum transmission distance possible for a given operating frequency.
 - c. lowest frequency that will provide communication over a specified distance at a given time.
 - d. highest frequency that will provide communication over a specified distance at a given time.
-

Continued on next page

Review Lesson, Continued

Item 26 Waves of frequency that are transmitted above the _____ will pass through the ionosphere and escape into space.

- a. MUF
 - b. FOT
 - c. LUF
 - d. UMF
-

Item 27 The lowest limiting frequency for satisfactory sky wave communication for a radio circuit at a particular time is known as the

- a. LUF.
 - b. LOF.
 - c. LTF.
 - d. LHF.
-

Item 28 The periodic increase and decrease of received radio strength is called

- a. noise.
 - b. reflection.
 - c. fading.
 - d. interference.
-

Item 29 The four types of fading are interference, polarization,

- a. absorption, and switch.
 - b. antenna, and skip.
 - c. absorption, and skip.
 - d. reflection, and skip.
-

Item 30 What type(s) of radio wave propagation are useful at the medium frequency band?

- a. Sky only
 - b. Sky and reflected
 - c. Ground only
 - d. Sky and ground
-

Continued on next page

Review Lesson, Continued

Item 31 In the high frequency band, what are the two types of wave propagation called?

- a. Direct and sky
 - b. Reflected and direct
 - c. Reflected and ground
 - d. Sky and ground
-

Item 32 Which of the ground wave components provides the best communications path when operating in the very-high-frequency band?

- a. Ground-reflected
 - b. Surface
 - c. Direct
 - d. Critical
-

Item 33 The direct wave component of the ground wave is the only reliable propagation path available when transmitting in the _____ frequency band.

- a. HF
 - b. ELF
 - c. ULF
 - d. UHF
-

Item 34 A device that converts the output power of the transmitter into an electromagnetic field for radiation into space is called

- a. transmitting antenna.
 - b. power converter.
 - c. RF amplifier.
 - d. AF amplifier.
-

Continued on next page

Review Lesson, Continued

Item 35 If a transmitter is supplying power to an antenna, the fluctuating energy sets up two fields. Which of these two fields remain at a short distance from the antenna and beyond?

- a. Radiation
 - b. Inductive
 - c. Magnetic
 - d. Electric
-

Item 36 The radiation field is composed of two components. They are the electric and _____ components.

- a. induction
 - b. magnetic
 - c. electron
 - d. oscillation
-

Item 37 What field is formed from the electric and magnetic components of a radiated wave?

- a. Electro-inductive
 - b. Electro-magnetic
 - c. Magnetic-induction
 - d. Electro-motive
-

Item 38 The purpose of a receiving antenna is to

- a. radiate energy into space.
 - b. vary the frequency of a radio wave.
 - c. send received signals to the modulator.
 - d. operate as a signal source for the receiver.
-

Continued on next page

Review Lesson, Continued

- Item 39** Polarization of a radiated wave is determined by the direction of the lines of force making up the _____ field.
- a. magnetic
 - b. induction
 - c. electric
 - d. radiation
-

- Item 40** What are the two types of antenna polarization?
- a. Vertical and omni-directional
 - b. Vertical and horizontal
 - c. Horizontal and directional
 - d. Azimuthal and vertical
-

- Item 41** What kind of antenna polarization should you use when working with low and medium frequencies?
- a. Induction
 - b. Horizontal
 - c. Electrical
 - d. Vertical
-

- Item 42** Why is it better to horizontally polarize antennas at high frequencies?
- a. They can be made to radiate effectively at high angles.
 - b. They are omni-directional.
 - c. Vertically radiated waves cannot be refracted from the ionosphere.
 - d. Vertically polarized antennas have inherent directional properties.
-

Continued on next page

Review Lesson, Continued

- Item 43** At the very-high and ultra-high frequency bands, which type(s) of antenna polarization should be used?
- a. Vertical polarization only
 - b. Horizontal polarization only
 - c. Neither vertical nor horizontal
 - d. Either vertical or horizontal
-

- Item 44** The AS-2259/GR makes use of short-range sky wave propagation to communicate over distances ranging from _____ miles.
- a. 0 to 150
 - b. 0 to 200
 - c. 0 to 250
 - d. 0 to 300
-

- Item 45** What is the maximum input power of the OE-254/GRC?
- a. 300 watts
 - b. 350 watts
 - c. 400 watts
 - d. 3,500 watts
-

- Item 46** The balun of the OE-254/GRC is responsible for
- a. adjusting the height of the antenna.
 - b. securing the radiating elements to the mast.
 - c. allowing the operator to adjust the impedance.
 - d. matching the impedance of the antenna to the input.
-

Continued on next page

Review Lesson, Continued

Item 47 Aligning the antenna to the outstation and adding or subtracting the wave angle can direct the major lobe of the _____ antenna toward the intended receiver.

- a. half-wave dipole
 - b. long wire
 - c. quarter-wave whip
 - d. ground plane
-

Item 48 A half-rhombic antenna when terminated with a resistor becomes

- a. uni-directional.
 - b. omni-directional.
 - c. bi-directional.
 - d. directional.
-

Item 49 When making a field expedient ground plane antenna, at what length (in wave) should the vertical and ground plane elements be cut?

- a. One-quarter wave
 - b. One-half wave
 - c. Three-quarter wave
 - d. One full wave
-

Item 50 A conductor that transfers radio frequency energy from the transmitter to the antenna is called a _____ line.

- a. repeater
 - b. carrier
 - c. transmission
 - d. pulse
-

Continued on next page

Review Lesson, Continued

- Item 51** Ease of construction is just one advantage to using the _____ transmission line.
- a. shielded pair
 - b. parallel two-wire
 - c. continuous pair
 - d. twisted pair
-

- Item 52** High cost is one disadvantage to using the _____ transmission line.
- a. coaxial
 - b. continuous pair
 - c. twisted pair
 - d. shielded pair
-

- Item 53** What is one advantage of using the shielded pair transmission line?
- a. Ease of construction
 - b. Readily accessible material
 - c. Low cost of material
 - d. The conductors are balanced to ground
-

- Item 54** Standing waves result in
- a. a fire hazard in the area below the antenna.
 - b. a power loss and poor antenna efficiency.
 - c. improved reception and greater power output.
 - d. a perfect antenna and transmission line match.
-

- Item 55** Antenna masking is the technique of
- a. causing antenna dispersion.
 - b. using decoy antennas.
 - c. using remote control radios.
 - d. hiding radio signals behind terrain.
-

Continued on next page

Review Lesson, Continued

- Item 56** One advantage of using horizontal polarization in an EW environment is that it
- cannot be seen from the sky.
 - causes ease of construction in an open area.
 - has no radiation to be detected by the enemy.
 - has a more stable signal in or near dense woods.
-

- Item 57** The purpose of grounds is to
- introduce the least possible amount of resistance in the ground connection.
 - have resistance as high as possible.
 - have conductivity as low as possible.
 - increase ground losses and to provide the best energy from the antenna.
-

- Item 58** Which type of grounding device is made from galvanized iron or steel and pointed at one end?
- Radial ground
 - Ground screen
 - Grounding rod
 - Counterpoise
-

- Item 59** A grounding system consisting of a number of interconnected bare conductors arranged radially and buried a short distance under ground is known as a
- radial ground.
 - counterpoise.
 - grounding rod.
 - ground screen.
-

Continued on next page

Review Lesson, Continued

- Item 60** A structure made from wire that is erected a short distance off the ground and insulated from the ground describes a
- a. ground rod.
 - b. counterpoise.
 - c. ground screen.
 - d. radial ground.
-

- Item 61** Which grounding system reduces ground absorption losses that occur when an antenna is erected over imperfectly conducting ground?
- a. Ground rod
 - b. Counter screen
 - c. Ground screen
 - d. Radial ground
-

Item 62 Through Item 64 Matching: For items 62 through 64, match the atmospheric layer in column 1 to its description in column 2. Place your responses in the spaces provided.

Column 1	Column 2
<u>Atmospheric Layer</u>	<u>Description</u>
___ 62. Troposphere	a. The region of the atmosphere that extends from the surface of the earth to a height of about 6.8 miles
___ 63. Ionosphere	b. The region of the earth's atmosphere composed of several distinct layers
___ 64. Stratosphere	c. The region of the earth's atmosphere where the temperature remains nearly constant

Continued on next page

Review Lesson, Continued

**Item 65
Through
Item 68**

Matching: For items 65 through 68, match the polarization benefit in column 1 to the type of polarization in column 2. Place your responses in the spaces provided.

Column 1

Column 2

Polarization Benefit

Type of Polarization

- | | |
|---|------------------------------|
| ___ 65. Useful in minimizing interference from certain directions | a. Vertical
b. Horizontal |
| ___ 66. Useful when communicating with moving vehicles | |
| ___ 67. Is somewhat less effected by aircraft flying over the transmission path | |
| ___ 68. Suffers lower losses when located near dense forests | |
-

**Item 69
Through
Item 73**

Matching: For items 69 through 73, match the antenna characteristics in column 1 to the antenna system in column 2. Place your responses in the spaces provided.

Column 1

Column 2

Antenna Characteristics

Antenna System

- | | |
|--|--------------------------------|
| ___ 69. Operates in the VHF range, between 30 and 88 MHz | a. AS-2259/GR
b. OE-254/GRC |
| ___ 70. A omni-directional, biconical antenna | |
| ___ 71. Utilizes radiating elements that double as guy lines | |
| ___ 72. Operates in the HF range, between 2 and 12 MHz | |
| ___ 73. Radiating elements are steel tubes that screw into a central balun | |
-

Continued on next page

Review Lesson, Continued

**Item 74
Through
Item 80**

Matching: For items 74 through 77, match the field expedient antenna in column 1 to the illustration in column 2. Place your responses in the spaces provided.

Column 1

Field Expedient Antenna

- ___ 74. Half-wave dipole
- ___ 75. Long wire
- ___ 76. Sloping "V"
- ___ 77. Vertical quarter wave whip

Column 2

Illustration

a.

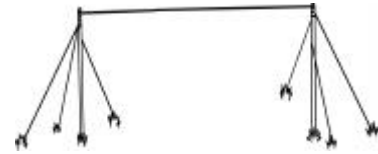

b.



c.

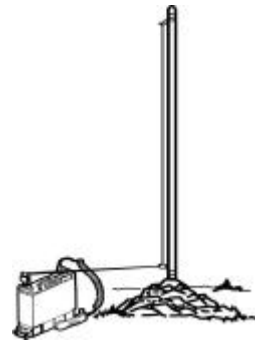

d.

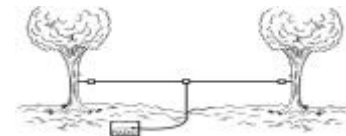

Continued on next page

Review Lesson, Continued

**Item 78
Through
Item 80**

Matching: For items 78 through 80, match the field expedient antenna in column 1 to the illustration in column 2. Place your responses in the spaces provided.

Column 1

Field Expedient Antenna

- ___ 78. Two-element
- ___ 79. Half-rhombic
- ___ 80. Ground plane

Column 2

Illustration

a.

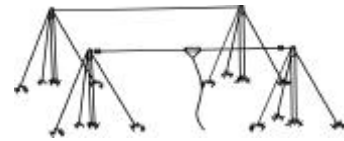

b.



c.



Continued on next page

Review Lesson, Continued

**Item 81
Through
Item 84**

Matching: For items 81 through 84, match the type of transmission line in column 1 to the illustration in column 2. Place your responses in the spaces provided.

Column 1

Type of Transmission Line

- ___ 81. Shielded pair
- ___ 82. Twisted pair
- ___ 83. Parallel two wire
- ___ 84. Coaxial cable

Column 2

Illustration

a.



b.



c.



d.



Continued on next page

Review Lesson, Continued

**Item 85
Through
Item 89**

Matching: For items 85 through 89, match the factor for antenna site selection in column 1 to the type of category in column 2. Place your responses in the spaces provided.

Column 1

Column 2

Factor

Category

- | | |
|------------------------------------|--------------|
| ___ 85. Local command requirements | a. Technical |
| ___ 86. Location | b. Tactical |
| ___ 87. Manmade obstructions | |
| ___ 88. Cover and concealment | |
| ___ 89. Remote operations | |
-

Review Lesson Solutions

Answers

The table below lists the answers to the review lesson examination items. If you have questions about these items, refer to the reference page.

Item Number	Answer	Reference
1	b	1-5
2	b	1-5
3	c	1-5
4	a	1-5
5	d	1-6
6	a	1-7
7	d	1-8
8	a	1-14
9	c	1-14
10	d	1-15
11	a	1-16
12	d	1-18
13	c	2-5
14	c	2-5
15	d	2-8
16	c	2-8
17	b	2-9
18	c	2-9
19	c	2-9
20	d	2-16
21	d	2-16
22	b	2-38
23	a	2-17
24	b	2-19
25	d	2-24
26	a	2-24
27	a	2-26
28	c	2-30
29	c	2-31
30	d	2-38
31	d	2-38
32	c	2-38
33	d	2-38

Continued on next page

Review Lesson Solutions, Continued

Item Number	Answer	Reference
34	a	3-4
35	a	3-4
36	b	3-4
37	b	3-4
38	d	3-5
39	c	3-12
40	b	3-12
41	d	3-14
42	a	3-14
43	d	3-14
44	d	3-23
45	b	3-27
46	d	3-27
47	b	3-37
48	a	3-39
49	a	3-42
50	c	3-48
51	d	3-50
52	a	3-51
53	d	3-51
54	b	3-52
55	d	4-12
56	d	4-14
57	a	4-18
58	c	4-19
59	a	4-20
60	b	4-21
61	c	4-22
62	a	2-6
63	b	2-6
64	c	2-6
65	b	3-16
66	a	3-15

Continued on next page

Review Lesson Solutions, Continued

Item Number	Answer	Reference
67	a	3-15
68	b	3-16
69	b	3-25
70	b	3-25
71	a	3-22
72	a	3-23
73	b	3-25
74	d	3-34
75	a	3-37
76	b	3-40
77	c	3-41
78	a	3-36
79	b	3-39
80	c	3-42
81	b	3-51
82	c	3-50
83	a	3-50
84	d	3-51
85	b	4-6
86	a	4-4
87	a	4-5
88	b	4-6
89	b	4-7
