

THE APOCALYPSE

DEFINITELY MAYBE
COMING TO A SUBURB NEAR YOU



WILDFIRE

FLOOD

HURRICANE

CIVIL DISORDER

ALIEN INVASION

\$\$\$ COLLAPSE

VOLCANO

TIDAL WAVE

EARTHQUAKE

BLACK SWAN

Crisis

SIX WAYS TO DIE WHILST BUGGING OUT

No. 1: Be Clueless

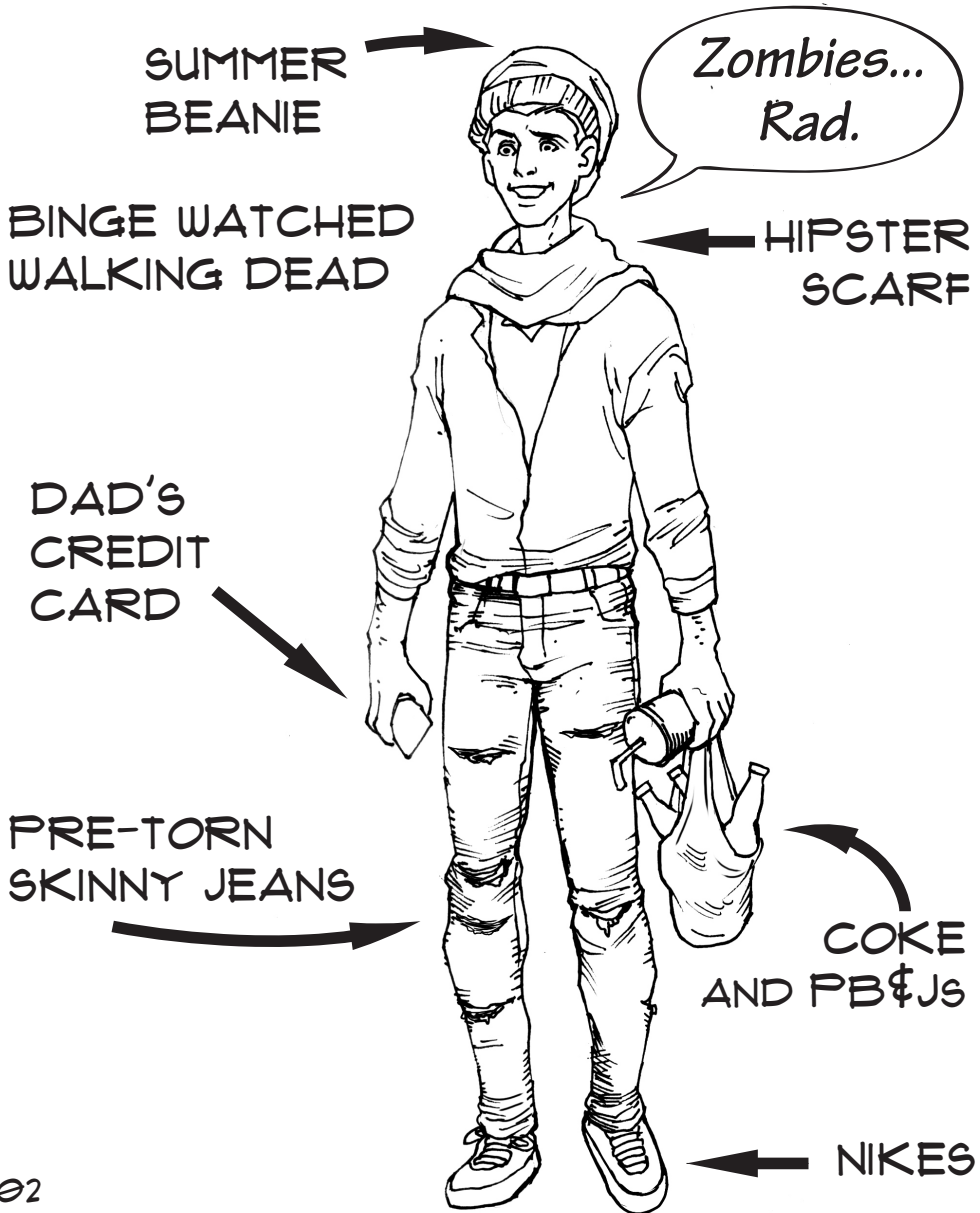

Way to Die No. 2

BE A LONE WOLF

ISSUES WITH
AUTHORITY

STEELY-EYED
INDIVIDUALIST

CARRIES →
HUGE ROPE
(NO IDEA WHY)

ARMED
TO THE
TEETH →

USUALLY
ON THE
NAUGHTY
LIST

NO COMMUNITY

ZERO
BACKUP

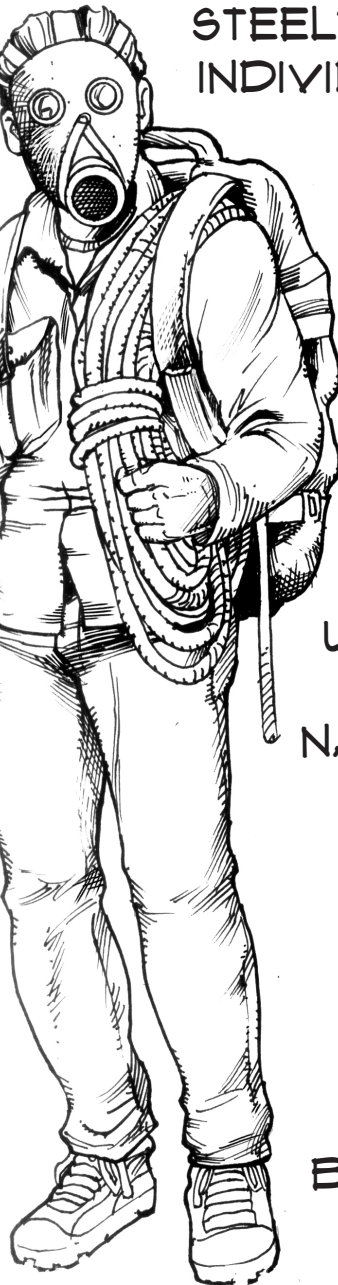

Way to Die No. 3

BE A GEAR WHORE

AR-15
WEIGHS
NINE POUNDS

SIXTEEN
FIRE
STARTERS

AR500
STEEL
PLATES

FOUR
WATER
FILTERS

CAMO
UNDER-
PANTS

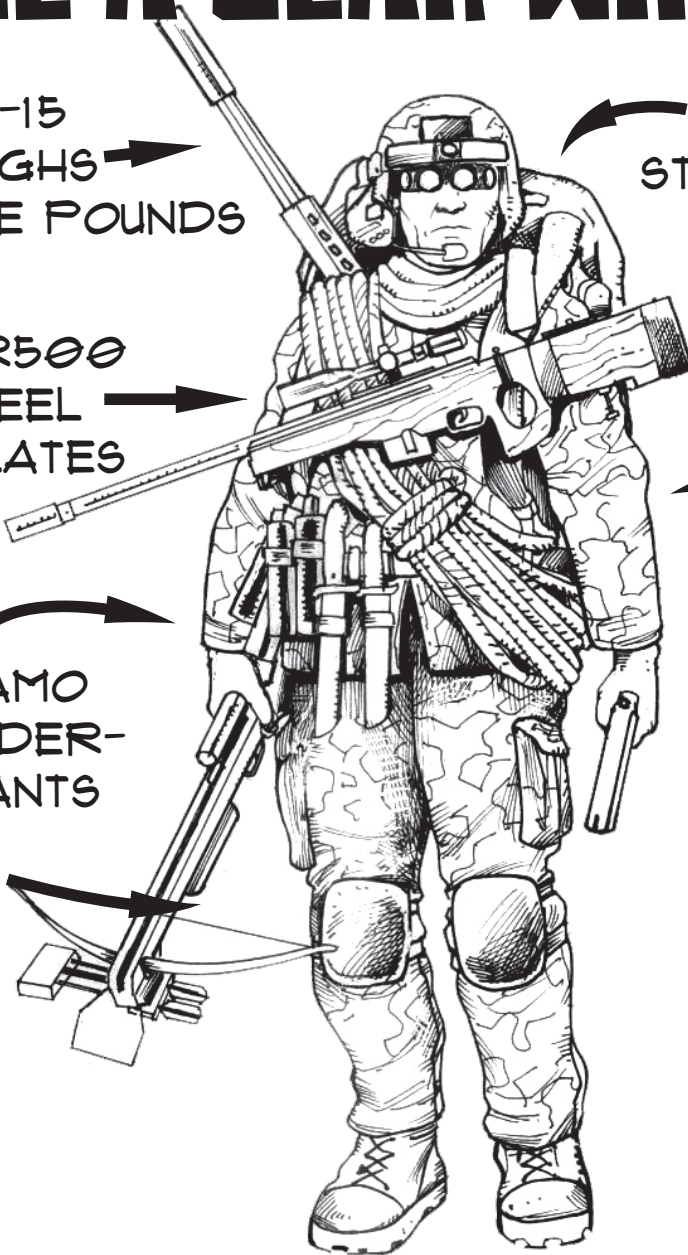

NEVER LEAVES HOME WITHOUT AT
LEAST FIVE KNIVES

Way to Die No. 4

GO FULL

MOUNTAINMAN

GONNA BUILD HIM A
HOME IN THE WOODS

THREE RIFLES

GILL NET
(SAW IT ON
ALONE)

ANIMAL
TRAPS

LUMBERJACK
AXE



Way to Die No. 5

DON'T PLAN FOR THE WHOLE FAM

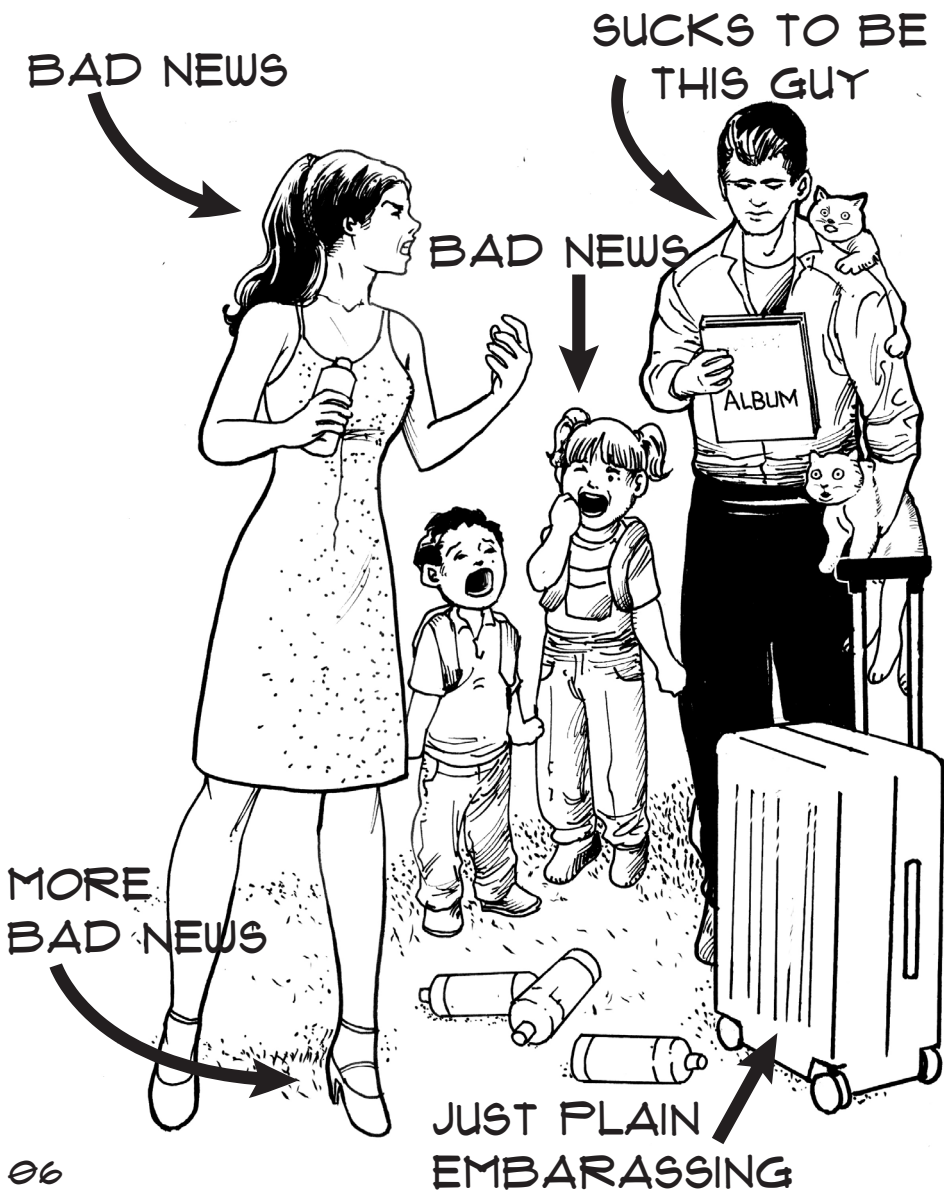

Way to Die No. 6

BE AN A-HOLE

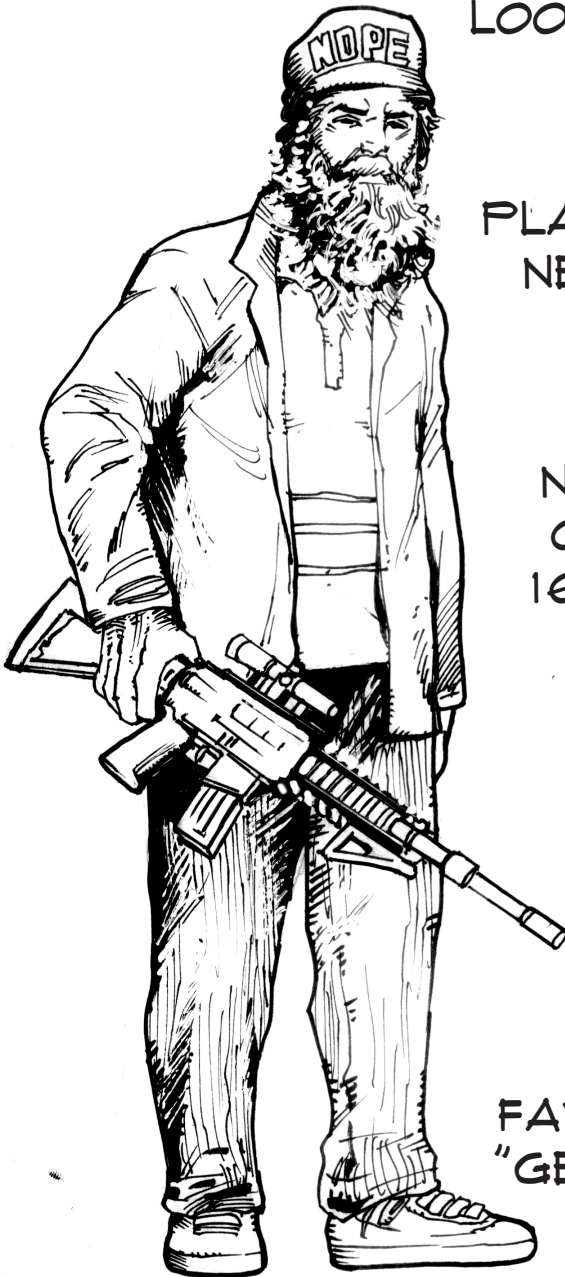

LOOKING FORWARD
TO SEEING IT
ALL BURN

PLANS ON STEALING
NEIGHBOR'S FOOD
AN HOUR AFTER
"THE BIG ONE"

NEIGHBORS PLAN
ON SHOOTING HIM
10 MINUTES AFTER
"THE BIG ONE"

HATES HUMANS
(AND CATS,
BUT HE'S RIGHT
ABOUT
THE CATS)

FAVORITE PHRASE:
"GET OFF MY LAWN"

HE WHO SURVIVES

SURVIVOR BOB

HAS A BUG OUT LOCATION*
(SOMEWHERE TO ACTUALLY GO!)

HAS FRIENDS
& FAMILY
WITH THE
PROGRAM

TRAVELS
HEAVY
IN HIS
CAR AND
LIGHT ON
FOOT

HAS A
FOUR
SEASON
PLAN!

PRACTICES HIKING AND TESTS GEAR
WITH THE FAMILY EVERY YEAR OR SO.

* "BUG OUT LOCATION" IS A "BOL" TO
HARD-CORE SURVIVOR TYPES.





STAY HOME, BRO.

DON'T LEAVE HOME UNLESS YOU
ABSOLUTELY **MUST**, BECAUSE YOUR HOME
IS QUITE LITERALLY YOUR CASTLE.



HOME IS **KNOWN** TERRITORY.
HOME CONTAINS **ALL** YOUR STUFF.
HOME IS **FAMILIAR**-YOU'LL FREAK OUT LESS.
HOME HAS **NEIGHBORS** WHO YOU KNOW.



BUT, IF YOUR HOME GETS TOO DANGEROUS,
IT'S TIME TO GO!

WARNING: LIFE OR DEATH INFO

HAVE SOMEWHERE TO BUG OUT TO
BEFORE THE BIG ENCHILADA

CAMPSITE YOU SWIPED



GOOD

BUG OUT LOCATION IN THE WOODS



BETTER

FARM PROPERTY IN A COMMUNITY



BEST!!



FIRST AND BEST OPTION

DRIVE TO YOUR BUG OUT LOCATION.

YOU SHOULD DO EVERYTHING POSSIBLE TO KEEP YOUR WHEELS. WALKING COULD BE A DEATH SENTENCE, ESPECIALLY WITH A FAMILY.

TAKE MULTIPLE VEHICLES SO IF ONE CRAPS OUT, YOU HAVE ALTERNATIVES. LOAD THEM WITH EVERYTHING POSSIBLE. YOU'LL BE FORCED TO LEAVE MANY CRITICAL SUPPLIES BEHIND. ONE CAR CAN SERVE AS A FUEL TANKER. DUMP THAT CAR AND SIPHON THE FUEL TO CONTINUE TO YOUR "BOL."

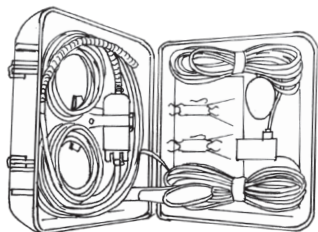

DRAINING GAS FROM A HOLE IN THE TANK IS DAMN NEAR IMPOSSIBLE. (TRY IT IF YOU DON'T BELIEVE US.) THE **GAS TAPPER** IS A SURVIVOR'S BEST FRIEND.

SOCCER MOM ASSAULT VEHICLE.

RIDICULE THEM IF YOU PLEASE, BUT USED MINIVANS HOLD A LOT OF FOOD AND GEAR, AND ARE DIRT CHEAP.

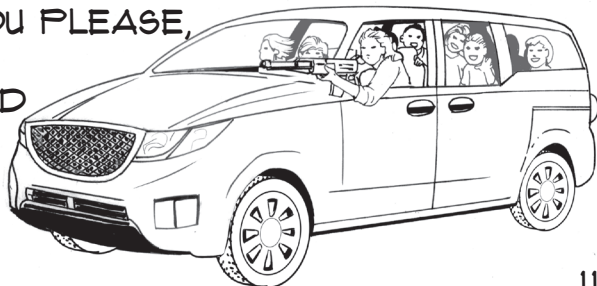

VEHICULAR BUG OUT LIST

1. TACTICOOOL STUFF (FINALLY!! GUNZ!)

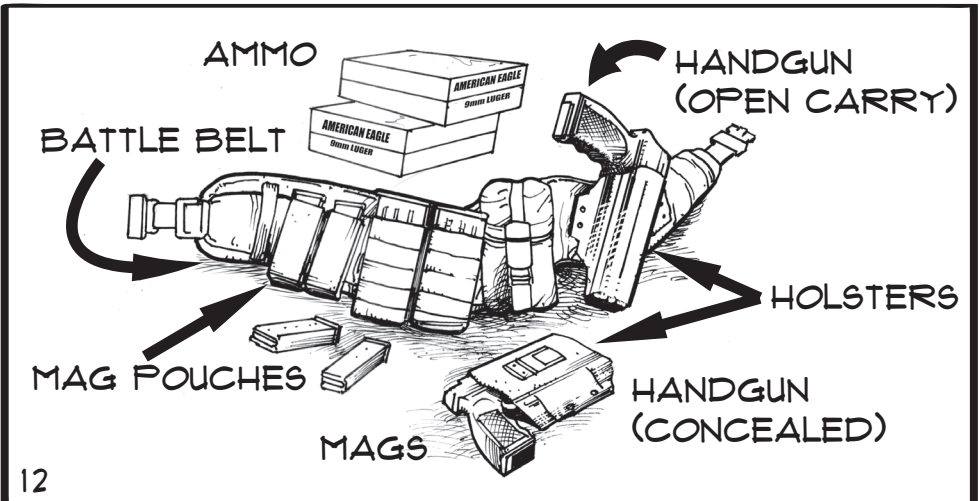
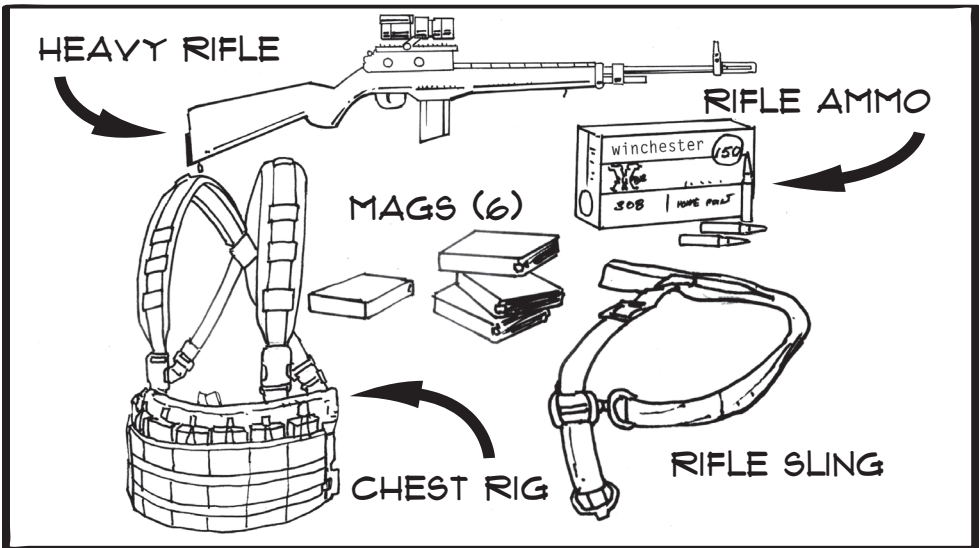

12

WHICH HANDGUN IS BEST?

IF YOU'RE ASKING THAT QUESTION, GET YERSELF A **GLOCK 17**. IF YOU ALREADY LOVE ANOTHER **GAT**, THEN LOVE THE ONE YER WITH, BROTHER.

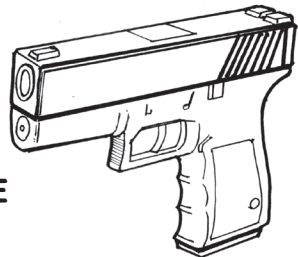

VEHICULAR BUG OUT LIST

MORE TACTICOOOL STUFF!

WHICH ASSAULT RIFLE IS BEST??

THE AR-15 VS. THE AK-47

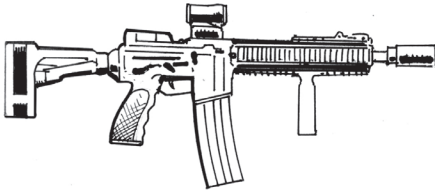

TRICK QUESTION!

THE BEST RIFLE FOR YOU MIGHT BE A HUNTING RIFLE OR A SHOTGUN. IT DEPENDS ON IF YOU LIVE IN AN URBAN MAZE, A TIGHT FOREST OR A WIDE-OPEN MOUNTAIN RANGE.

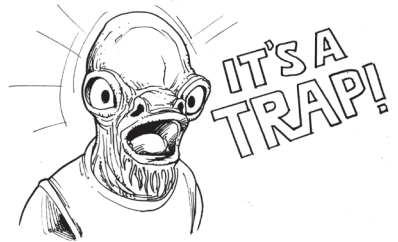

THE AK-47 IS MUCH MORE RELIABLE, BUT THE AR-15 IS MORE ACCURATE AND MORE EASILY CUSTOMIZED. AR-15 PARTS AND AMMO ARE EASIER TO SCROUNGE AFTER A COLLAPSE. IF YOU SPEND LOTS OF TIME TRAINING, THE AR-15 MIGHT BE BEST. IF YOU OPEN THE BOX WHEN THE ZOMBIES APPEAR, THEN BUY AN AK-47.



FN/FAL 7.62 HEAVY RIFLE

REMINGTON 700 RIFLE

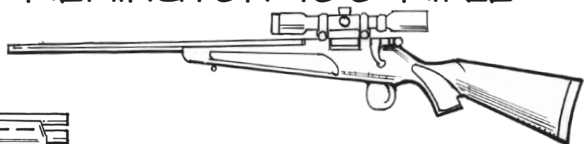

REMINGTON 870 SHOTGUN

VEHICULAR BUG OUT LIST

MEGA ULTRA TACTICOOOL (\$\$\$)



NIGHT VISION GOGGLES

NYGS ARE WORTH **TEN** EXTRA GUNS. THEY'RE EXPENSIVE

(\$3K GIVE OR TAKE.) WITHOUT THEM, YOU'LL SCURRY LIKE A MOUSE IN THE NIGHT.

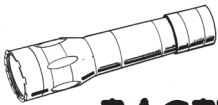
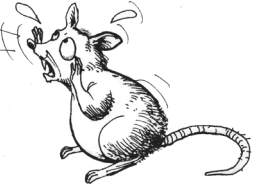

TACTICAL FLASHLIGHT

LARGE BINOCULARS
(DON'T SCRIMP ON THESE)
AND A **BINO HARNESS** LIKE
HUNTERS USE.



BUMP HELMET. HOLDS YOUR NYGS AND YOUR PELTORS IF YOU CAN AFFORD 'EM. SADLY, NOTHING ON THIS PAGE IS "POOR MAN."

IT'S IMPOSSIBLE TO KEEP UP WITH BRAND PRODUCTS, SO WE'VE MADE A FREE APP TO SUGGEST SPECIFIC PRODUCTS FOR EACH BUDGET.

WWW.PLAN2BUGOUT.COM

VEHICULAR GRUB

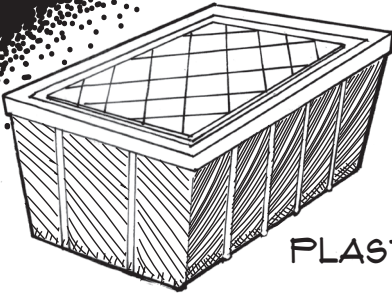

PLASTIC TOTES

WATER JUGS

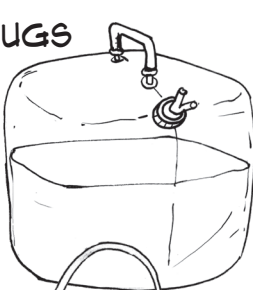

KETTLE

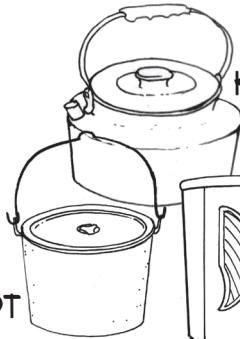

POT

JETBOIL

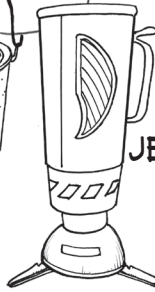

SPORKS



FUEL



WATER FILTER

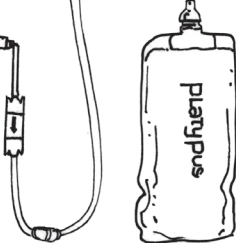

PLATES

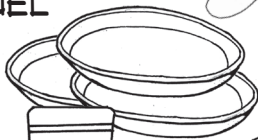

FOOD



COFFEE



SOAP

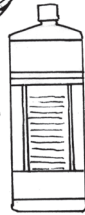

PAPER TOWELS



VEHICULAR SHELTER

EVEN IF YOU'RE DRIVING A CAMPER, YOU MAY NOT WANT TO SLEEP IN IT. SAWING LOGS INSIDE A CAR CAN LEAVE YOU COLD AND BLIND, PARTICULARLY IN A HIGH-THREAT ENVIRONMENT. PREP A WAY TO SLEEP AWAY FROM YOUR VEHICLE IN CASE THINGS GET DICEY. PLUS, SLEEPING INSIDE MOST VEHICLES SUCKS.

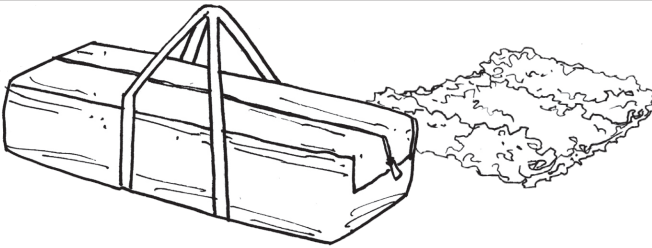

FAMILY TENT
+ CAMO COVER

SLEEPING PAD. WITHOUT AN INSULATIVE LAYER BETWEEN YOU AND THE GROUND (TENT DOESN'T COUNT) YOU WILL FREEZE YOUR BUTT OFF IN ALMOST ANY WEATHER..

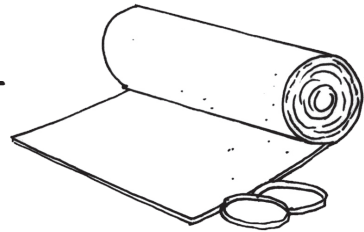

40 DEG.

15 DEG.

0 DEG.

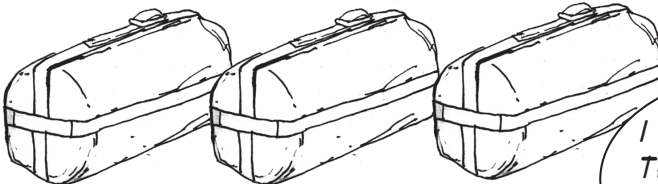

YOU NEED ONE SLEEPING BAG FOR **EACH MAJOR SEASON**. IF YOU HAVE A 40 DEGREE BAG, AND IT'S ZERO DEGREES OUTSIDE, YOU'RE GOING TO HAVE TO FIND A **TAUNTAUN** TO HACK OPEN AND SLEEP INSIDE.

I THOUGHT THESE THINGS SMELLED BAD ON THE OUTSIDE.



JUNK IN YER TRUNK

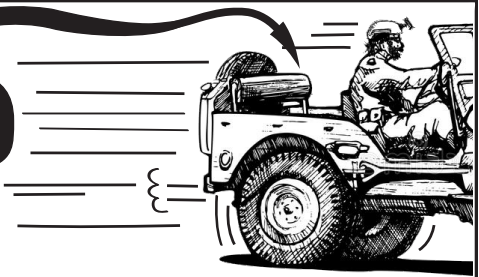

AXE SHARPENING
PUCK



FIXED BLADE

FOLDER

SHARPENER

HATCHET

SILKY SAW

HEADLAMP

MULTI-TOOL

XTRA
BATTERIES

MAPS OF
YOUR AREA

ANALOG
WATCH

GPS

WALKI-
TALKIES

SHORTWAVE
RADIO

CHAPSTICK

N95 MASK

GAS MASK

TRAUMA
FIRST AID
KIT

CAFFEINE
PILLS

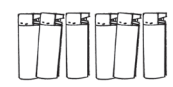

LIGHTERS

POOR MAN'S CAR ARMOR

RECIPE FOR **STRANGELY EFFECTIVE** CAR ARMOR.

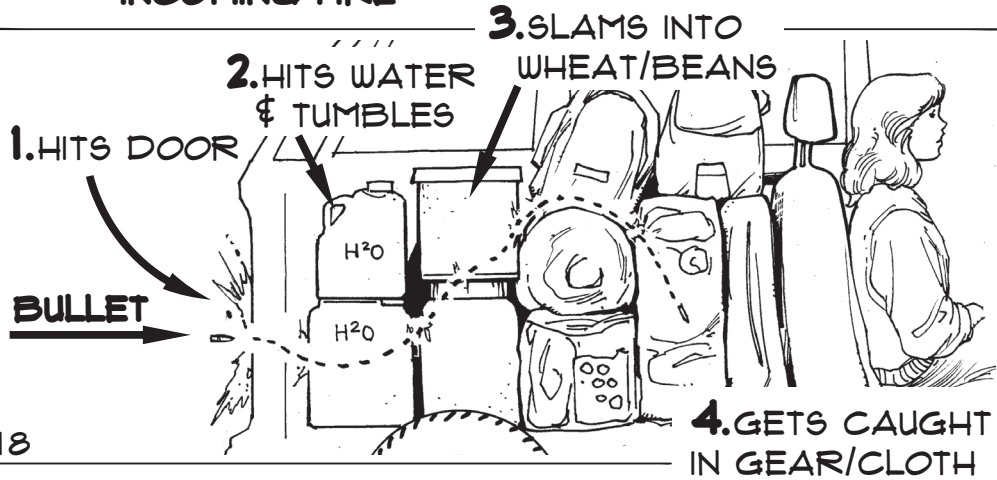
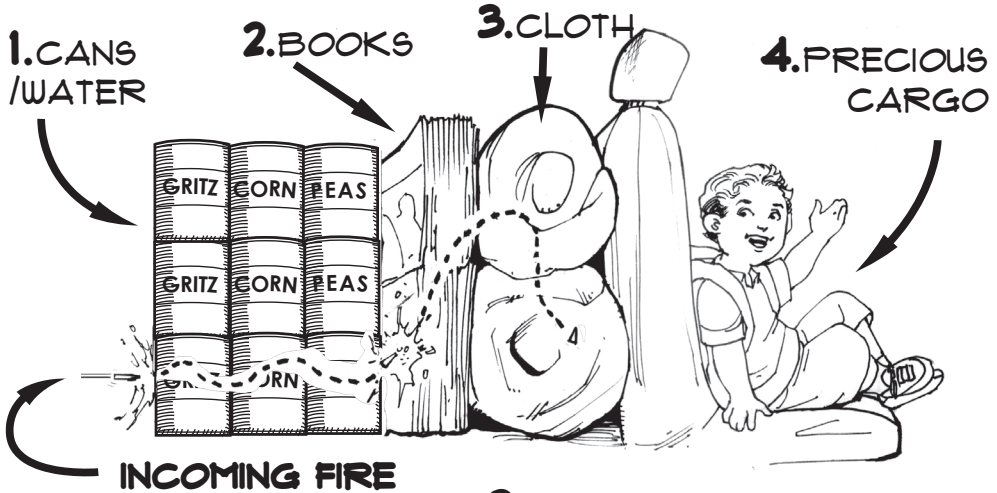

18

IMPORTANT: WATER, GAS OR CANNED GOODS MUST BE THE FIRST THING THE BULLET HITS. THE BULLET WILL GO STRAIGHT THROUGH BOOKS IF IT HITS THEM FIRST.

WATER MAKES THE BULLET **TUMBLE** AND THAT'S THE KEY. THEN THE BOOKS/CLOTH CAN STOP IT.

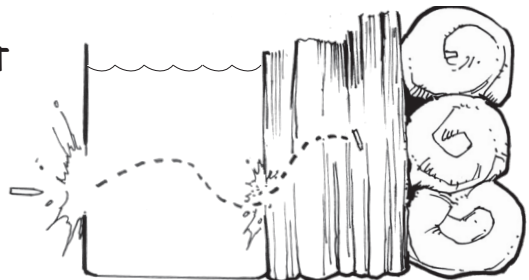

CAR FIRST AID

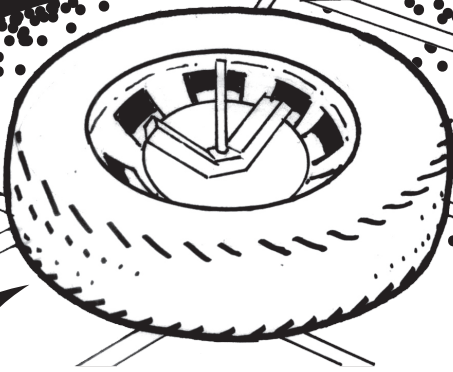

FULL SPARE TIRE

TIRE REPAIR
AEROSOL

TIRE PLUG KIT

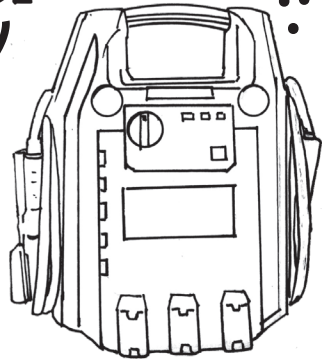
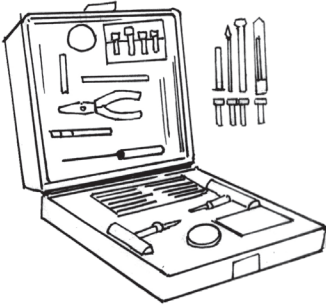

JUMP
STARTER
BATTERY

TOW STRAP

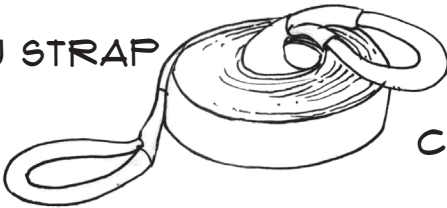

CHUBBEL

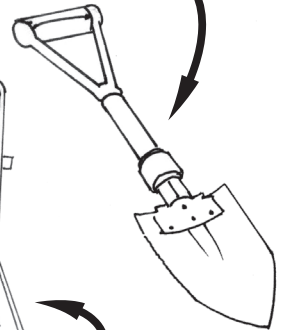

GASTAPPER

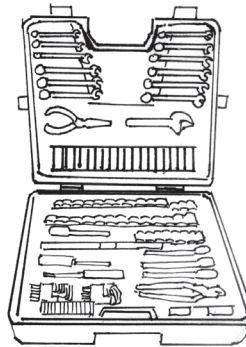
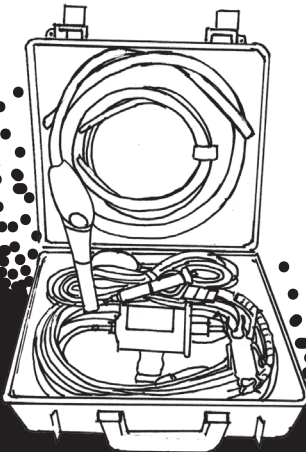

AUTO TOOL KIT

...IF YOUR CAR SH*TS THE BED

→ PLAN B ←

*OR IF THE ROADS ARE JACKED

A CAR OR TRUCK PROVIDES LOTS OF COVER (WEATHER, WIND, SUN, PHYSICAL ATTACK AND BULLETS-SORTA.) YOU SHOULD KEEP YOUR WHEELS AT ALL COSTS. BUT IF THE ROADS ARE HOPELESS, YOU MUST PLAN OTHER ROLLING OPTIONS. THEY ALL BEAT THE HELL OUT OF WALKING.

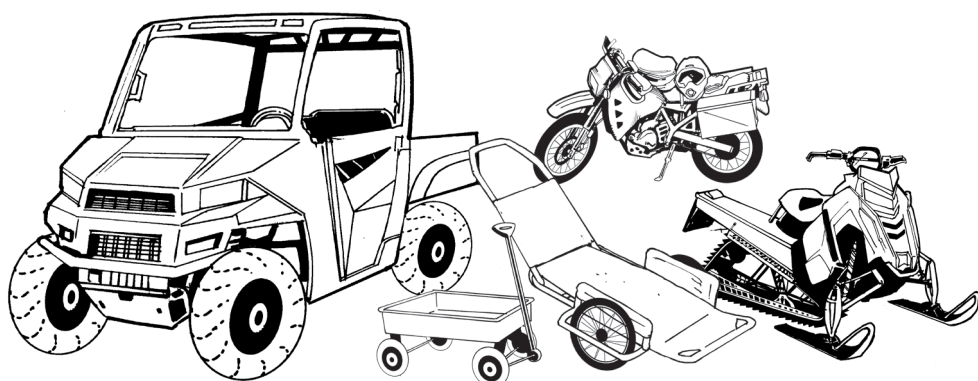

TOW, RACK OR PACK YOUR SECONDARY SET OF WHEELS. SO, IF YOUR VEHICLE RUNS OUT OF GAS OR RUNS OUT OF ROAD, YOU'LL STILL HAVE OPTIONS A HECK OF A LOT BETTER THAN WALKING.

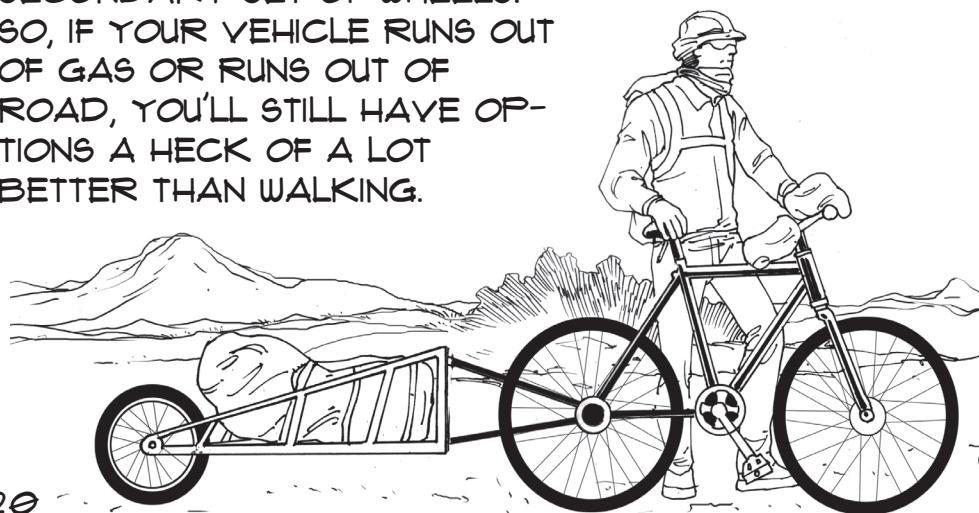

"Two is one, and One is none."

(an axiom to ignore when Bugging Out.)

PREPPERS: BEFORE BURNING US AT THE STAKE, CONSIDER THE SAD REALITY THAT YOU HAVE **ONLY TWO KNEES, TWO FEET AND TWO HIPS** (AND NONE OF THEM ARE "EXTRA.") IF YOU BUGGER THEM UP WHILE BUGGING OUT, YOU ARE SUPER SCREWED.



THE CUTOFF POINT FOR OVERLAND TRAVEL ON FOOT IS ABOUT SIX DAYS. IF YOUR BOL IS FURTHER THAN SIX DAYS ON FOOT, THEN IT'S TOO FAR TO WALK.

THAT DEHYDRATED FOOD WEIGHT IS DO-ABLE WITHOUT KILLING THE FEET.

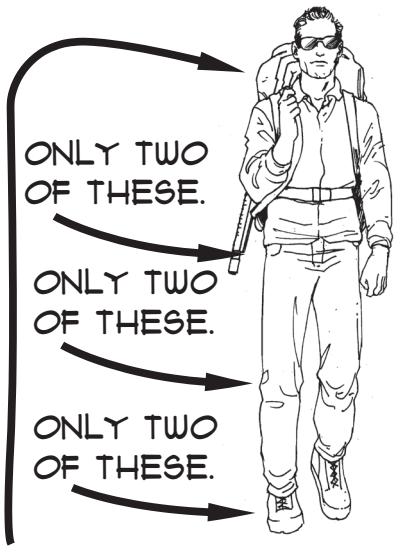

DON'T TRADE THEM FOR SIX FIRE STARTERS AND THREE WATER FILTERS!

10 LBS.
FAST, BUT LIMITED RANGE.

20 LBS.
6 DAYS RANGE
FAST & LIGHT.

45 LBS.
FEET QUIT LONG BEFORE FOOD RUNS OUT



The Legendary Hiking Bug Out

ODDS OF THE APOCALYPSE HAPPENING DURING SUMMER CAMPING SEASON ARE ONLY 30%. ACCORDING TO **MURPHY'S LAW**, IT'LL HAPPEN WHEN THE WEATHER'S **HORRIBLE**. ARE YOU READY TO BUG OUT IN SUCKY WEATHER?

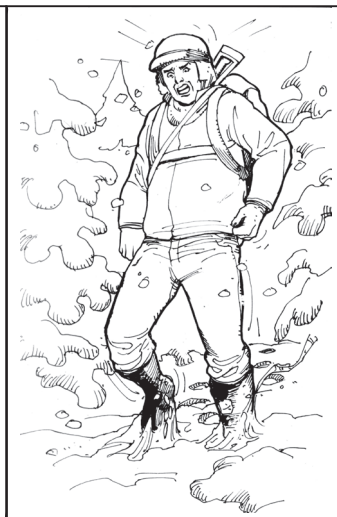
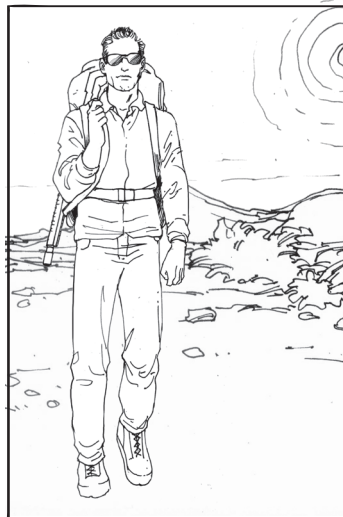

WHERE'S WALDO? WALDO'S SETTING A PAUTE DEADFALL LIKE A STUDMUFFIN BUSHCRAFTER LIVING OFF THE LAND. **BUT WAIT!** WHO'S THAT, ABOUT TO SHOOT HIM AND STEAL HIS BACKPACK?...



SPEED IS OFTEN SECURITY. GETTING TO YOUR "BOL" SAFELY MEANS NOT FOOLING AROUND IN THE WOODS. **MOVE FAST.** DON'T FORAGE, FISH OR FART AROUND.

ULTRALIGHT BUGGIN' OUT

WHEN YOU CARRY GEAR YOU DON'T ABSOLUTELY NEED, YOU RADICALLY REDUCE YOUR RANGE AND SPEED. THE CURE TO GEAR-NORRHEA IS ULTRA-LIGHTNESS. IT'S LIKE WEIGHT WATCHERS FOR YOUR **BOB** AND REQUIRES ABOUT THE SAME AMOUNT OF DISCIPLINE

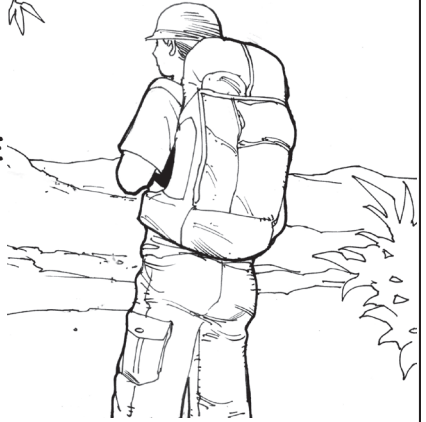

NOTICE: YOU STILL GET TO BE A **GEAR WHORE**, BUT YOU MUST BE A **GEAR WHORE** WITH A POSTAL SCALE (GOOD TO ONE-TENTH OF AN OUNCE.)

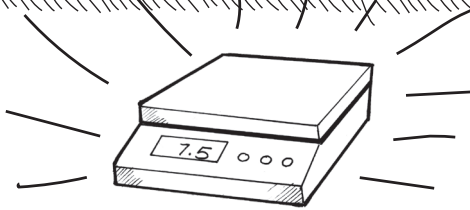

JEFFERY 3:21

PACK THOU ONLY LIGHT THINGS, FOR THY SOUL SHALL REJOICE IN THY FLEETNESS..

THY BUG OUT BAG
SHALL NOT WEIGH
MORE THAN
TWENTY
POUNDS
LEST THY KNEES
AND FEET BE SMOTE.





MIND OFFICIALLY BLOWN

20 POUND BUG OUT BAG?

(YES, SOME TOUGH GUYS POOP BIGGER THAN THAT.)

JUST TRUST US. THIS IS TOTALLY DO-ABLE EVEN ON A BUDGET. YOUR FEET, KNEES, HIPS AND BACK WILL BUILD A SHRINE IN YOUR HONOR.



AIN'T GONNA HAPPEN. MAH KNIFE WEIGHS FOUR POUNDS ALONE.

DO OR DO NOT. THERE IS NO TRY.

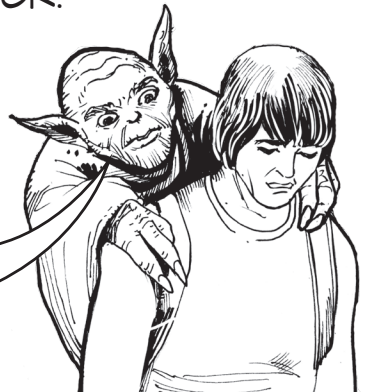

HOW THE HECK DO YOU GET A PACK UNDER 20 POUNDS WITH EVERYTHING?
ONE TENTH OF AN OUNCE AT-A-TIME.

BACKPACKING TENTS

IF YOU CAN GET TO YOUR **BOL** IN ONE, LONG WALK--OR IF IT'S NOT COLD OR RAINY--DUMP THE TENT. OTHERWISE, HERE ARE THREE LIGHT OPTIONS.



RICH MAN'S OPTION:
ZPACKS DUPLEX
(2 MAN). \$600, 19.4 OZ
(WITHOUT STAKES OR
TREKKING POLES,
WHICH YOU'RE GONNA
NEED.)

WORKING MAN'S:
SIX MOONS DESIGNS
GATEWOOD CAPE.
(1 MAN). \$135, 11.0 OZ.
NO FLOOR BUT DOUBLES
AS YOUR ULTRA LIGHT
RAIN PONCHO!



POOR MAN'S TENT:
TYVEK TARP WITH
CORNER GROMMETS
OR ROCKS TIED IN THE
CORNERS.
(2 MAN)
\$19.00, 19.4 OZ.

ULTRALIGHT SLEEPING BAG HACKS

THE SLEEPING BAG IS THE HEAVIEST BIT OF YOUR BUG OUT BAG, SO GETTING THE RIGHT TEMP RATING AT THE LOWEST WEIGHT IS WORTH THE EFFORT.

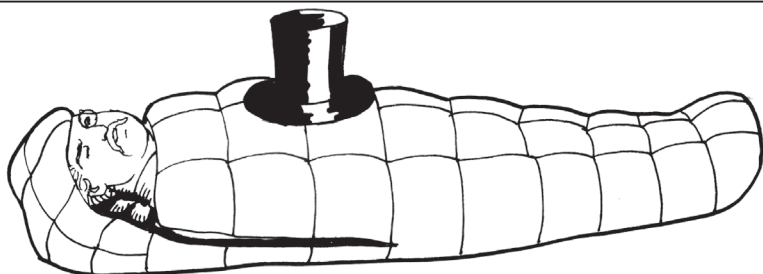

RICH MAN'S: WESTERN MOUNTAINEERING HIGHLIGHT 2 DEGREE BAG. \$380, 16.0 OZ. DITCH THE STUFF SACK AND CRAM THE BAG INTO YOUR PACK TO SAVE 2 OUNCES. HALLELUJAH!

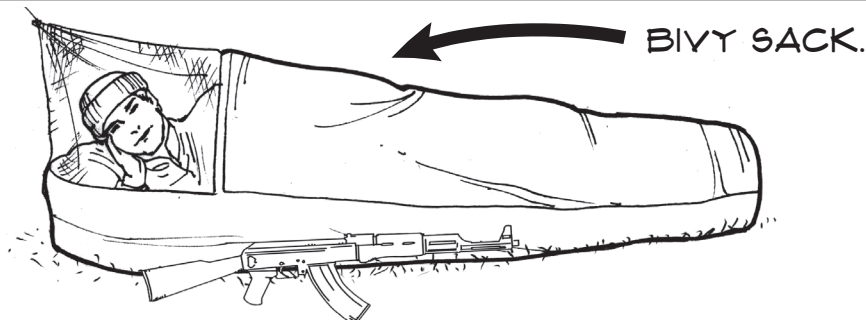

WORKING MAN'S: REI IGNEO 25. \$190, 30.0 OZ. ADD A BIVY SACK TO ADD 5-10 DEGREES TO THE BAG RATING. **BONUS:** THE BIVY SACK CAN TAKE THE PLACE OF YOUR TENT AS A VAPOR BARRIER AND WIND SHIELD--SAVING ALMOST A POUND AND A FEW HUNDRED BUCKS. BUT HEAVEN HELP YOU IF IT RAINS OR SNOWS. (KEEP A TARP NEARBY.)

UL SLEEPING BAG HACKS CONT.

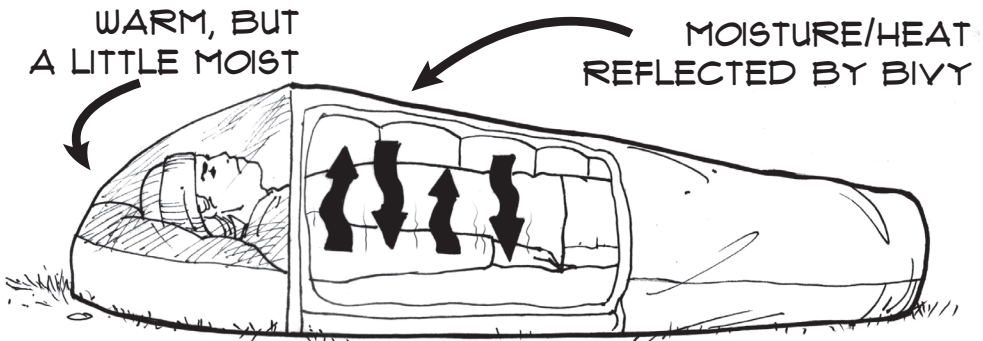

BIVY SACK: KATABATIC BRISTLECONE BIVY. \$165. 9.1 OZ. HERE'S THE TRUTH ABOUT BIVY SACKS, EMERGENCY BLANKETS AND TRASH BAGS: THEY ARE VAPOR BARRIERS AND YOU MAY HATE THEM BECAUSE THEY CAN BE HOT AND WET. (BIVY IS LEAST WET OF ALL, BECAUSE IT BREATHES MOST.)

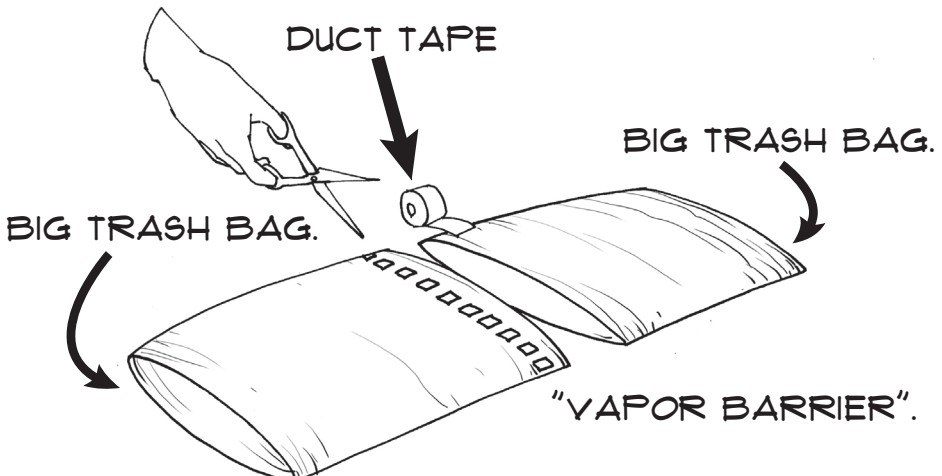

POOR MAN'S OPTION: CHEAPO SLEEPING BAG INSIDE TWO TRASH BAGS. \$1.24 19.4 OZ. (DEPENDS ON THE CHEAPO BAG). CUT THE BOTTOM OFF A TRASH BAG AND DUCT TAPE TWO TRASH BAGS TOGETHER. VOILA! YOU HAVE A VAPOR BARRIER!

*PLAN ON PULLING THE TRASH BAG (VAPOR BARRIER) ON AND OFF ALL NIGHT AS YOU WARM AND THEN FREEZE IN ALTERNATING STATES OF MISERY.

sleeping trickzzz

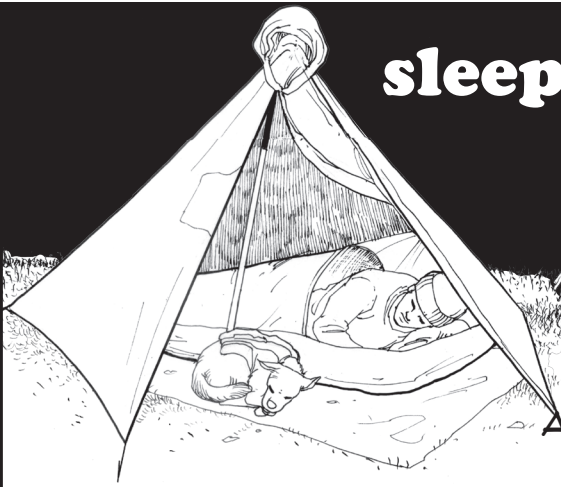

A TERRIBLE NIGHT'S SLEEP CAN BE A SURVIVAL RISK. INVEST PRECIOUS OUNCES IN GOOD SLEEP

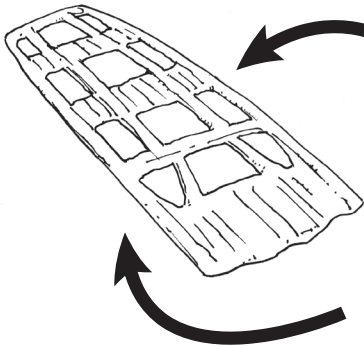

SLEEPING PAD. IF YOU DON'T PUT AN INSULATION BARRIER BETWEEN YOUR BUTT AND THE GROUND, YOU WILL FREEZE IN ALMOST ANY WEATHER.

FOR ULTRA LIGHT, WE LOVE THE **KLYMIT INERTIA X** (\$48, 5.4 OZ.) THE RAILS KEEP YOU FROM SLIDING OFF AT NIGHT (MOSTLY.)

FAIR WARNING: IF YOU USE AN ULTRA LIGHT, INFLATABLE SLEEPING PAD, BRING A PATCH KIT. KLYMITS COME WITH ONE.

FOR UP-TO-DATE PRODUCT RECOMMENDATIONS, GO TO WWW.PLAN2BUGOUT.COM FOR A FREE GUIDE.

PILLOW. MOST OF US SLEEP TONS BETTER WITH A PILLOW. STUFF YOUR EXTRA CLOTHES IN AN ULTRA LIGHT STUFF SACK AND USE IT AS A PILLOW. IF YOU GET COLD, PULL OUT EXTRA CLOTHES AND LAYER UP.

EXTRA CLOTHES IN A STUFF SACK

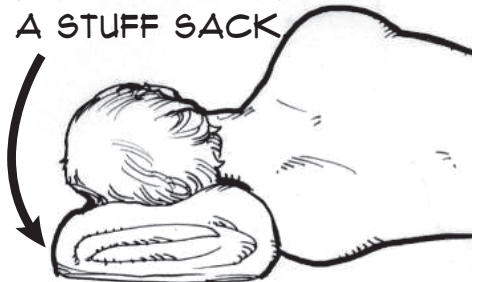

sleeping trickzzz cont.

WEARING CLOTHES IN YOUR SLEEPING BAG MAKES YOU COLDER (AND OTHER MYTHS YOUR SCOUTMASTER TOLD YOU.) THERE IS NO REASON NOT TO WEAR YOUR CLOTHING IN YOUR SLEEPING BAG. BY DOING SO, YOU ADD 5 DEGREES OR MORE TO YOUR BAG'S RATING, ESPECIALLY BY WEARING SOCKS, BEANIE AND YOUR PUFF JACKET. WEARING CLOTHES TO BED ALLOWS YOU TO BRING A LIGHTER SLEEPING BAG, SO WHY THE HECK NOT DO IT??

(BUT GIVE HIM A BREAK. THEY DIDN'T EVEN HAVE ULTRA LIGHT BACK THEN.)

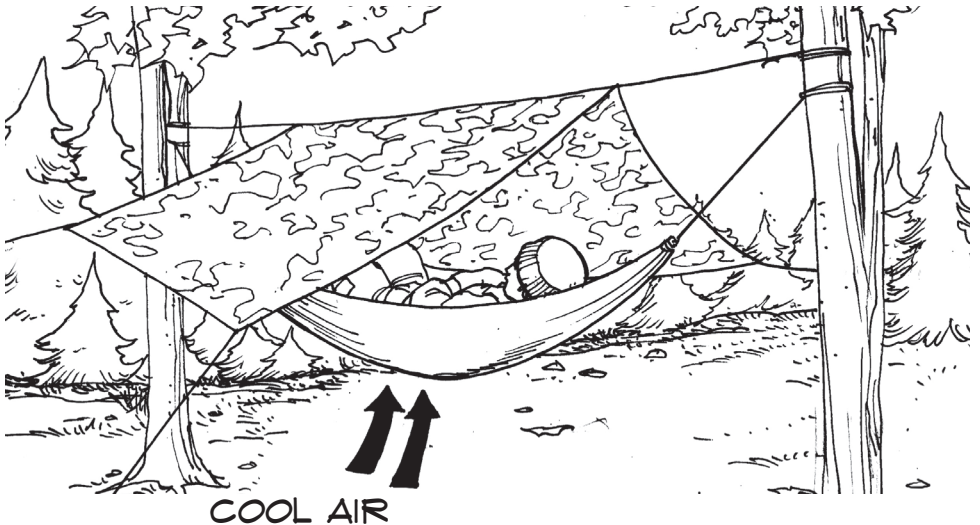

HAMMOCKS. IN WARM CLIMATES, AN ULTRA LIGHT HAMMOCK CAN TAKE THE PLACE OF YOUR TENT AND KEEP YOU OUT OF THE MUCK. ULTRALIGHT HAMMOCKS WEIGH ABOUT THE SAME AS TENTS/BIVYS. YOU WILL LIKELY NEED A PAD BETWEEN YOU AND THE HAMMOCK--OR THE AIR UNDER YOU WILL SAP YOUR BODY'S HEAT.

Featherweight Backpacks



WHERE THE **20 POUND**
BUG OUT BAG BEGINS.

HOW MANY BACKPACKS HAVE YOU SEEN FAIL ON THE TRAIL? YOU'RE MORE LIKELY TO CATCH A GLIMPSE OF SASQUATCH THAN SEE A BROKEN PACK. GOING MILITARY-GRADE WITH YOUR PACK IS LIKE PUTTING KEVLAR IN YOUR UNDERWEAR. WHY NOT BE A LITTLE MORE CAREFUL (LIKE YOU DO WITH YOUR TENT) AND SAVE THE WEIGHT?



POCKETS, CLIPS
AND STRAPS ARE
FOR SISSIES.

SINCE WE'RE
HAULING ASS
FROM A
DANGER ZONE

TO OUR **BOL**, WE
DON'T NEED A PACK THAT
WILL SURVIVE FORTY DAYS
EVADING THE TALIBAN IN THE
HINDU KUSH. WE NEED SOME-
THING *FAST* AND **LIGHT**. THAT
MEANS FEWER ZIPPERS AND
CLIPS AND LIGHTER MATERI-
ALS. SHAVE EVERY TENTH OF
AN OUNCE OFF THE BACK-
PACK *ITSELF*.

IF OUNCES ARE POUNDS,
AND IF AN OUNCE OF PREVEN-
TION IS WORTH A POUND OF
CURE, IS WEIGHING MY PACK IN
TENTHS OF OUNCES THE CURE?



Featherweight Backpacks cont.

RICH MAN'S OPTION: ZPACKS ARC BLAST 55L BACKPACK. \$325, 20.1 OZ. ULTRA LIGHT. FEW POCKETS. WATERPROOF. DECENT BELLY BAND. WE'VE TRIED MOST THE UL BACKPACKS UNDER RIGOROUS CONDITIONS AND THIS ONE OUT-PERFORMED THEM ALL.

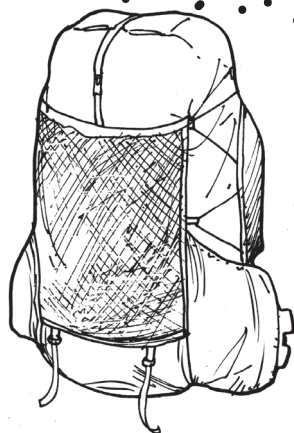

WORKING MAN'S OPTION: KLYMIT MOTION 60 BACKPACK. \$165, 41.4 OZ. DON'T BE AFRAID TO TRIM OFF EVERY BUCKLE, STRAP AND STRING THAT ISN'T ABSOLUTELY MISSION CRITICAL. WE WOULD DEFINITELY RIP OUT THE BELLY BAND PUMP-THING AND CUT THE STRAPS DOWN TO THE BARE MINIMUM.

POOR MAN'S OPTION: ANY SMALL DAYPACK WITH A BELLY BAND WORKS. \$5 AT THE THRIFT STORE. 30 OZ. AFTER DOING SURGERY. IF YOU PACK SMALL ENOUGH, YOU DON'T NEED A FANCY PACK. AFTER ALL, A SMALL PACK WEIGHS LESS THAN A BIG PACK. ACHIEVE ULTRA LIGHTNESS THROUGH SUPERIOR CHEAPNESS.



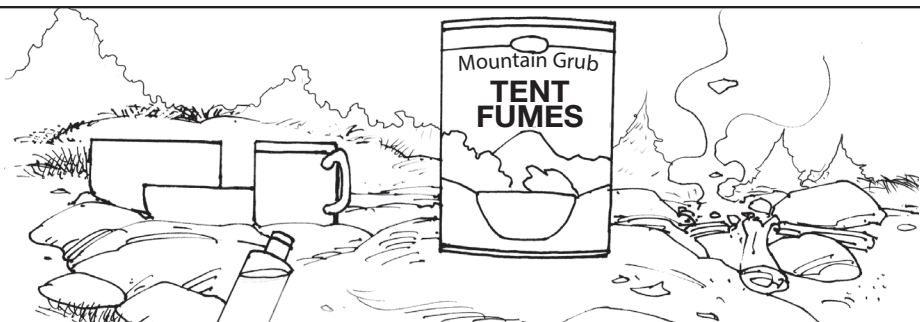

WITH FREEZE DRIED MEALS, YOU CAN CARRY SIX DAYS OF FOOD AND STILL BE UNDER 20 POUNDS, NO PROBLEM. HUNGER MAKES YOU STUPID, SO PACK PLENTY OF CARBS FOR YOUR BUG OUT. YOU'LL NEED YOUR WITS.

BUT, DO YOU NEED THE FOIL BAG THAT COMES WITH THE MEAL? DO YOU NEED THE OXYGEN ABSORBER? DO YOU EVEN NEED TO HEAT YOUR MEAL?



IF YOU HAVE TIME, PREP YOUR BUG OUT BAG BEFORE YOU HIT THE ROAD. MOVE ALL FREEZE DRIED TO LIGHT SANDWICH BAGGIES AND DITCH THE O₂ ABSORBERS. WRITE ON THE BAG HOW MANY CUPS OF WATER THE MEAL TAKES TO REHYDRATE.

RE-PACKAGED IN LIGHT SANDWICH BAGGIES, WEIGHT PER 1,000 CALORIES IS ABOUT 1.6 OZ. THAT'S DAMN IMPRESSIVE. **FREEZE DRIED IS AMAZING.**



PRO TIP: THE "SERVINGS" ON BACKPACKER MEALS WERE CALCULATED FOR 120 POUND EUROTRASH CHAIN SMOKERS, SO IF YOU'RE A STANDARD ISSUE AMERICAN MALE, DOUBLE THE SERVINGS PER PERSON.

ULTRA LIGHT STOVES

THE BEST **BUG OUT STOVE** IS ALSO THE
CHEAPEST STOVE!!

(EVAN HAFFER TESTED THEM ALL FOR US.)

EVERNEW POT STAND (\$11)

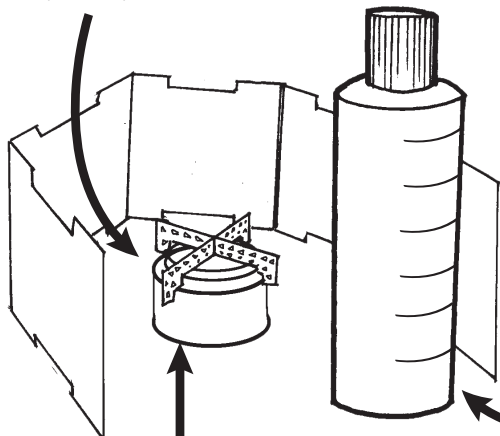

EVERNEW TITANIUM
ALCOHOL STOVE (\$33)

VARGO
WINDSHIELD (OPT.)

- * ZERO SMELL
- * ONLY THE FUEL YOU NEED
- * LIGHT!

PLASTIC BOTTLE WITH
DENATURED ALCOHOL.
(MARK EACH
1.5 OUNCES =
A TWO CUP BOIL)

**BACKUP: THE
READYMAN
POCKET STOVE
BURNS TINY TWIGS.**



—————➔ **COFFEE!**

CAFFEINE IS LIFE--OR AT LEAST IT'S A MORALE BOOSTER AND KEEPS YOU MORE ALERT. (WHICH CAN BE LIFE IN A BUG OUT.) **STARBUCKS VIA INSTANT COFFEE** ISN'T REALLY COFFEE, BUT IT'S PRETTY DAMN GOOD. AND IT'S OH-SO LIGHT.



GET THEE
BEHIND ME,
STARBUCKS!



CLEAN YER BUM & MOUTH*

*NOT IN THAT ORDER.

THE BRIDGE
FLOWS, THE WATER
IS MOTIONLESS.
WHY?

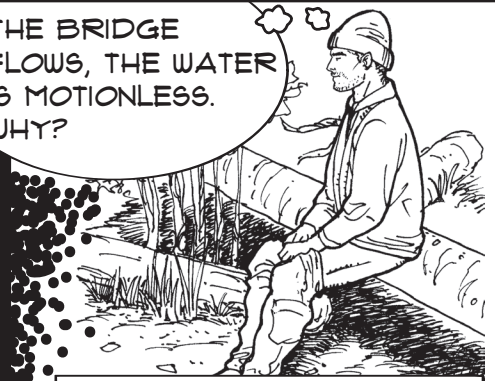

(EVERY MAN'S A
BUDDHIST WHEN POOPING)

EVEN ON THE MOVE, GOOD HYGIENE IS WORTH AN OUNCE OR TWO AND A MOMENT OF CONTEMPLATION.

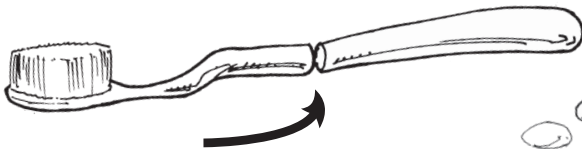

CUT-AND-DISCARD
TO SAVE A FEW TENTHS.

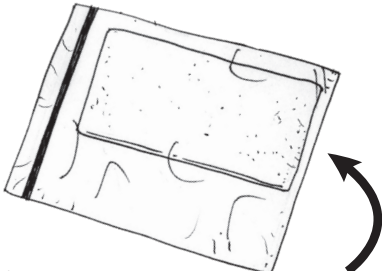

TWO WET WIPES PER DAY
SHOULD SUFFICE. ADD A
SPLASH OF WATER TO
THE BAGGIE RIGHT
BEFORE YOU BLAST OFF.



DRY IN "DOTS" AND
CARRY IN SNACK BAG..

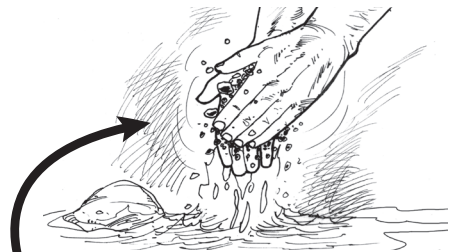

SOAP IS **HEAVY**. EITHER
CARRY A FEW DROPS
OF DR. BRONNER'S OR
SCRUB IN CREEK SAND.

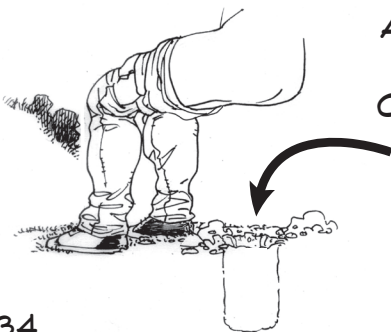

ALWAYS POOP **WELL** AWAY FROM
WATER, AWAY FROM TRAILS AND
CARVE A SMALL HOLE WITH YOUR
BOOT HEEL OR STICK FOR THE
LONG DROP.

"SURFACE SHITTERS DIE FOUL,
MERCILESS DEATHS."

JEFFREY 13:6

BUGOUT BACKPACK BLASTERS



WE **LOVE** OUR GUNS TOO. WE WRITE THEM ANNIVERSARY CARDS AND WORRY ABOUT THEM WHEN THEY'RE LONELY. BUT...**HONESTY TIME!**

GUNS ARE **HEAVY** AND **MAY** BE A LIABILITY WHEN BUGGING OUT. WE DIDN'T WANT TO BELIEVE IT EITHER!! WE TESTED IT MANY TIMES AND...**BAD NEWS.**

IF YOU'RE GOING TO BUG OUT ARMED, BE REALISTIC ABOUT WEIGHT. **EVEN A SEVEN POUND** RIFLE WILL BECOME A DESPISED BOAT ANCHOR THAT WILL WHEELDEE AWAY YOUR ALERTNESS AND STRENGTH.



LOVE LOOKS NOT WITH THE EYES, BUT WITH THE MIND, AND THEREFORE WING'D CUPID PAINTED BLIND.

MILE #1 **MILE #15**

I'M **CHUCKING** THIS SONOFABITCHIN' HUNK OF METAL IN THE NEXT DITCH I SEE...

REASONABLE GUN OPTIONS FOR BUGGING OUT:

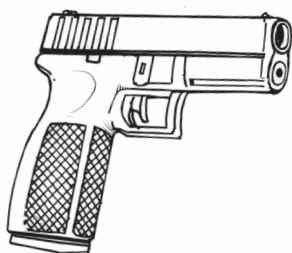

OPTION ONE: CARRY ONLY YOUR **HANDGUN**. A 9MM IS FAST AND POWERFUL. IN SOME SETTINGS, IT RIVALS AN AR. A HANDGUN IS CONCEALABLE, AVOIDING UNWANTED ATTENTION.

REASONABLE GUN OPTIONS FOR BUGGING OUT: CONTINUED...

OPTION NO. 2: CARRY

MINIMAL AMMO. AMMUNITION WILL BLOW YOUR 20 POUND LIMIT FASTER THAN GREEN GRASS THROUGH A GOOSE. REMEMBER: BUG OUT S.O.P. IS TO RUN FROM FIGHTS, NOT HUNKER DOWN AND PASTE 'EM WITH LEAD.

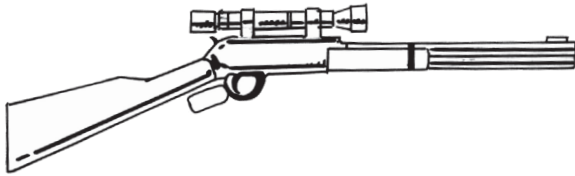

OPTION NO. 3:
FORGET HUNTING.
IF YOU'RE HUNTING YOU'RE PROBABLY TAKING TOO

LONG TO GET TO YOUR BOL. STASH YOUR HUNTING GUNS AT YOUR BUG OUT LOCATION AND HAUL ASS TO GET THEIR AS SOON AS POSSIBLE.

OPTION NO. 4: BUILD AN ULTRA LIGHT AR-15.

THERE AREN'T MANY RIFLES WITH ULTRA LIGHT POTENTIAL, BUT IT'S QUITE POSSIBLE TO BUILD A **FOUR POUND** AR-15.

IF YOU DON'T GO CRAZY ON AMMO (10 ROUNDS?) YOU CAN GET THE WHOLE WEAPON SYSTEM IN UNDER FIVE POUNDS WITH BANG-BANG.

FAIR WARNING: IT'S GOING TO COST YOU \$\$\$.

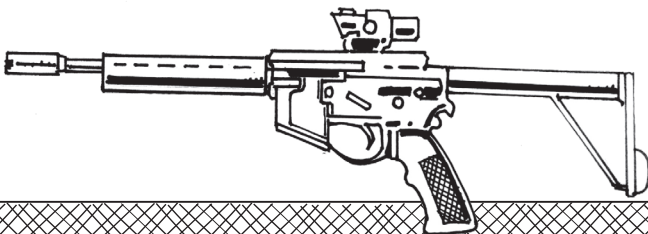

CLOTHING Layers & Layers

Like a Woman's Soul

PRO HIKERS WILL ATTEST: LAYERING YOUR CLOTHING IS KEY TO OVERLAND MOVEMENT. IF YOU'RE NOT STOPPING EVERY FEW MILES TO ADJUST YOUR LAYERS, YOU'RE PROBABLY SWEATING TOO MUCH AND YOU'RE GOING TO REGRET IT.

POLYESTER OR MERINO WOOL UNDERWEAR

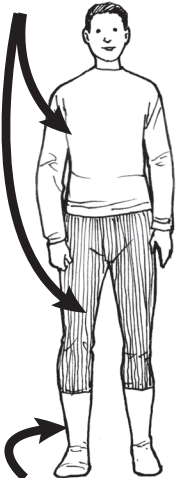

DARN TOUGH OR INJIN MERINO WOOL SOCKS

FLEECE LAYER



POLY BLEND PANTS



WOOL OR POLY BEANIE

ULTRA LIGHT WIND SHELL



SHELL PANTS FOR SNOW OR RAIN



ULTRA LIGHT PUFF JACKET



COTTON HAS NO PLACE IN YOUR BUG OUT BAG. IT GETS WET AND STAYS WET. COTTON KILLS.



WEAR THE LIGHTEST, MOST BREATHABLE BOOTS THAT WON'T GET WET INSIDE GIVEN CONDITIONS. LIGHTER BOOTS MEAN FEWER BLISTERS. BLISTERS WILL HALT YOUR BUG OUT FASTER THAN A PACK OF ZOMBIES.



NINJA WATER STRATEGY

HYDRATE, HYDRATE, HYDRATE, BUT THAT DOESN'T MEAN YOU GOTTA CARRY POUNDS OF WATER. CARRYING TOO MUCH WATER IS ONE OF THE ERRORS THAT SCREWS UP ULTRA LIGHT.

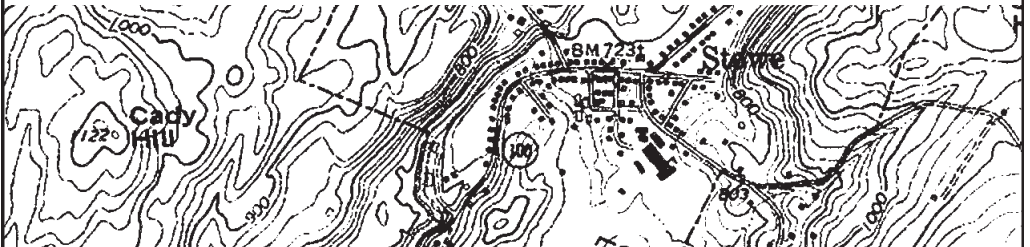

IF YOU KNOW YOUR BUG OUT ROUTE, YOU SHOULD KNOW WHERE TO FIND WATER IN WHICH SEASONS. CARRY **ONLY** ENOUGH WATER TO MAKE IT TO THE NEXT WATERING HOLE PLUS A MODEST RESERVE. WHEN YOU GET THERE, DRINK UP LIKE A CAMEL AND REFILL FOR THE NEXT LEG.



SAWYER MINI IS PROBABLY THE LIGHTEST, SIMPLEST BUG OUT FILTER ON THE MARKET. ALAS, IODINE TABLETS ARE LIGHTER, BUT...YUCK!
(\$20, 4.5 OZ.)

PLATYPUS MAKES AN ULTRA LIGHT BLADDER THAT'S DURABLE AND ALMOST WEIGHTLESS!
(2LITER) \$13, 1.3 OZ.

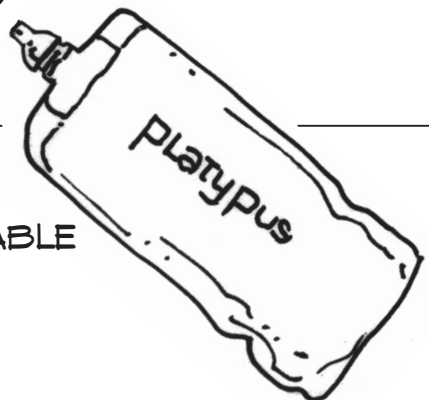

GRAYMAN

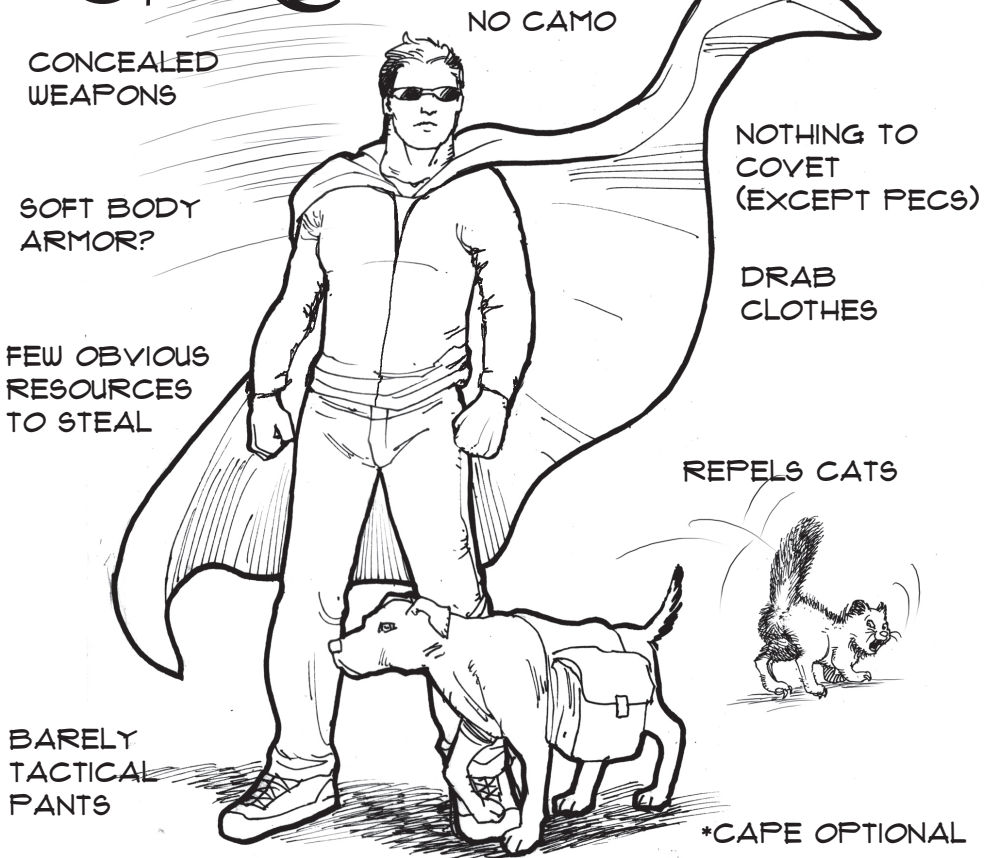

THE SUPERHERO OF BUG OUT. ESPECIALLY FOR THOSE BUGGING OUT OF THE BIG CITY, PERHAPS IT'S BEST TO LOOK JUST LIKE EVERYONE ELSE. BY WEARING DRAB COLORS AND HIDING ALL WEAPONS, ONE BECOMES LESS OF A TARGET FOR OPPORTUNISTS.

ULTRA LIGHT BUGGING OUT FITS WELL WITH GRAYMAN PHILOSOPHY--REDUCING GEAR TO AN UNATTRACTIVE LEVEL AND MAKING THE SURVIVOR LOOK LIKE ANOTHER HAPLESS REFUGEE.

maps

(BIG PAPER THINGS FROM BEFORE CELL PHONES)

KNOWING AND PRACTICING YOUR BUG OUT ROUTE WITH YOUR FAMILY WILL BLOW YOUR MIND. YOU'LL FIND DANGER POINTS, ROUTING MISTAKES AND SEASONAL PERILS. AT THE SAME TIME, YOU'LL LEARN WATER HOLES, ALTERNATIVE ROUTES AND MAYBE SET UP EMERGENCY EQUIPMENT CACHES.

PRINT TOPOGRAPHICAL MAPS OF YOUR BUG OUT AREA AT MYTOPO.COM (\$\$\$) AND USE THEM TO PRACTICE LAND NAVIGATION WHILE YOU EXPLORE YOUR BUG OUT ROUTE.

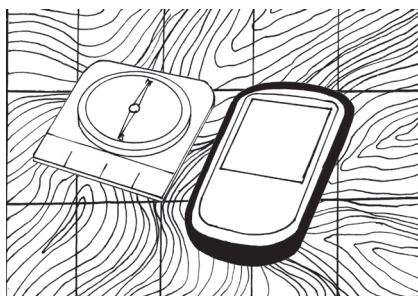

COMPASS OR GPS? YES TO BOTH. A GPS ISN'T MUCH GOOD IF YOU DON'T KNOW WHERE YOU ARE ON A MAP. WILL GPS WORK IN A COLLAPSE? IT'S A DEFINITE MAYBE. WILL A **SILVA** COMPASS WORK? FOR SURE.

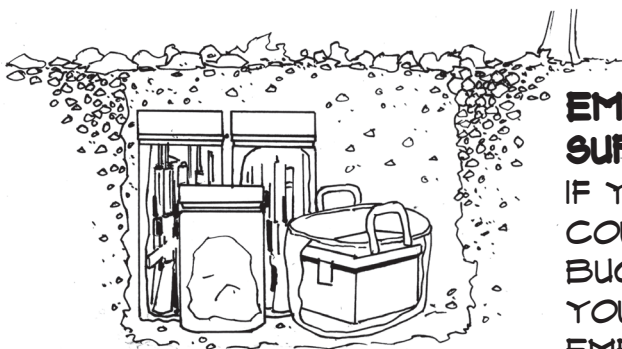

EMERGENCY SUPPLY CACHES

IF YOU'RE ABSOLUTELY COUNTING ON YOUR BUG OUT TO SAVE YOUR FAMILY, BURY EMERGENCY SUPPLY

CACHES ALONG THE WAY. IF YOU'RE ROBBED OR YOU LOSE YOUR KIT, YOU CAN RESUPPLY EN ROUTE.

Fire Starter Showdown

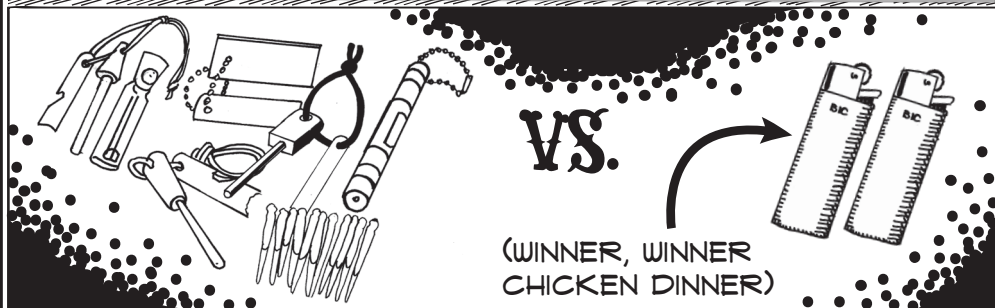

BUMMER ALERT: THE MOST ICONIC SURVIVAL GADGETS ARE ALSO THE WORST IDEA. FIRE STARTERS MOSTLY SUCK AND MANY WILL LET YOU DOWN IN A PINCH.

CONVERSELY, THE HUMBLE BIC LIGHTER WEIGHS 0.9 OUNCES AND RARELY FAILS. CARRY TWO OR THREE AND CONSIDER YOURSELF SUFFICIENTLY BADASS.

HOWEVER STARTING A FIRE IN THE RAIN OR THE DAMP CAN BE CHALLENGING EVEN WITH A BLOW TORCH. YOU NEED SUPREME POOR MAN TECH TO START A FIRE IN A DOWNPOUR.

Ultimate Poor Man Fire Starter

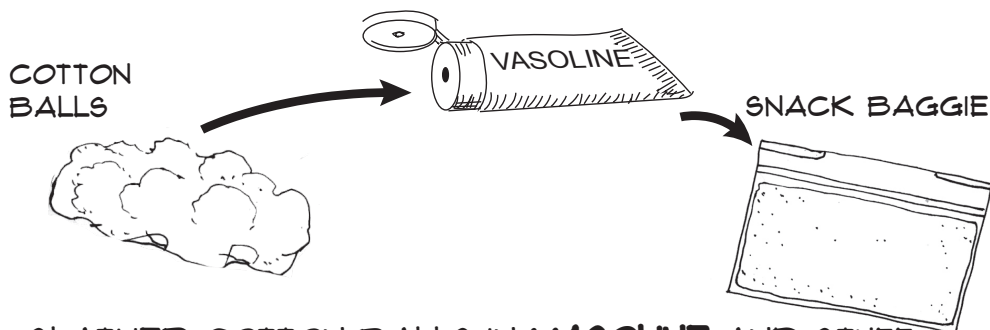

SLATHER COTTON BALLS IN **VASOLINE** AND STUFF THEM IN A ZIPLOC SNACK BAGGIE FOR MEGA TINDER THAT WORKS IN JUST ABOUT ANY WEATHER.

micro mini

FIRST AID KIT

REMINDER: BUGGING OUT IS JUST A TRIP TO YOUR BUG OUT LOCATION. DON'T TRY TO CARRY A FULL TRAUMA FIRST AID KIT. IRONICALLY, THAT COULD KILL YOU. WE SUGGEST A VERY SIMPLE KIT THAT DOESN'T EVEN HAVE BAND AIDS. (OH, THE HORROR!)

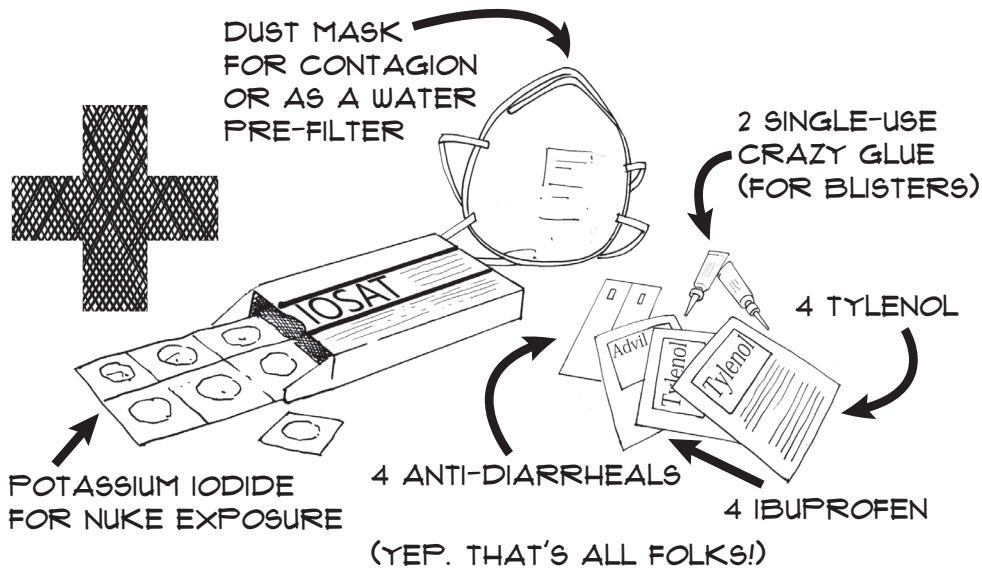

micro mini

FLASHLIGHTS

FEATHERWEIGHT AAA LIGHTS ARE ALL YOU REALLY NEED. HECK, LEARN TO MANAGE WITHOUT WITHOUT ARTIFICIAL LIGHT AS MUCH AS POSSIBLE. IT'S A GOOD SKILL LIGHT IS RISKY ANYWAY.

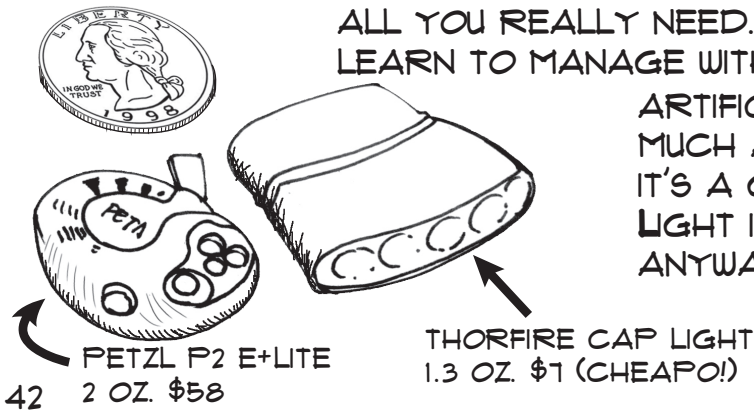

KNIVES, AXES, SWORDS, TOMAHAWKS & SHOVELS.



**COOL SHIT YOU MOSTLY
DON'T NEED.**

WE'VE PRACTICED BUGGING OUT MORE THAN ANYONE WE'VE EVER TALKED TO, AND WE'VE NEVER NEEDED MORE THAN THIS ONE, TEENSY BLADE--AND WE PROBABLY ONLY NEEDED A RAZOR BLADE (POOR MAN OPTION.) IF YOU'RE PLANNING ON KNIFE FIGHTING OR HACKING OUT A SHELTER, YOU NEED TO RETHINK YOUR BUG OUT PLAN. THE **SPYDERCO LADYBUG** (1 OZ., \$40) CUTS CORD, WHITTLES TINDER AND GUTS FISH. IF YOU NEED A BIGGER KNIFE BUGGING OUT, WE HAVE NO IDEA WHY.

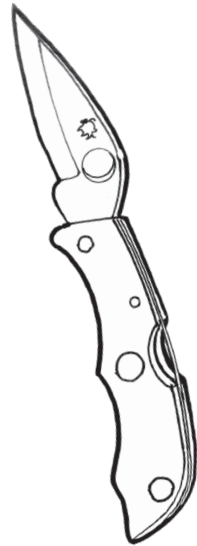

POTS AND PANS BECAUSE WE DUMPED THE FREEZE DRIED FOIL PACKET, WE NEED SOMETHING TO HEAT WATER AND MIX FOOD (HEATING FOOD IS OPTIONAL, THO.) **YARGO TITANIUM BOT** (\$87, 4.1 OZ.) OR **GSI HALULITE ALUMINUM** (\$22, 8.6 OZ)

An illustration of a man and a woman standing next to a dog. The man is holding a rifle, and the woman is holding a long-barreled rifle. A dog is sitting between them. The background is a decorative border of black dots.

KIDS & PETS

THE KEY TO BUGGING OUT WITH KIDS IS TO KEEP WHEELS UNDER THEM. KEEP YOUR CAR AS LONG AS POSSIBLE. SWITCH TO A BIKE AND TRAILER IF YOU MUST. NEVER WALK IF YOU CAN HELP IT.

- IF YOU HAVE TO WALK, MAKE SURE YOU HAVE A STROLLER, WAGON OR HANDCART. YOUR KIDS CAN KILL YOUR WHOLE FAMILY IF YOU DON'T PLAN WELL

IF YOU HAVE DOGS, TRAIN THEM TO CARRY AT LEAST THEIR OWN FOOD AND WATER. DOGS ARE EXCELLENT FOR BUGGING OUT AS THEY CAN CARRY THEIR OWN SUPPLIES AND STAND GUARD WHILE THE FAMILY SLEEPS.



IN CAR BUG OUT LIST

- Heavy Rifle*
- Rifle Ammunition
- Heavy Rifle Magazines (6)
- Heavy Rifle Sling
- Chest Rig
- Handgun (Open Carry)*
- Handgun (Concealable)*
- Handgun Ammunition
- Handgun Magazines (3 +1)
- Holster (Open Carry)
- Holster (Concealed)
- Handgun Magazine Pouch
- Tactical Flashlight
- Large Binoculars
- Water Jugs 10 gal./person
- Water Filter
- Water Additive
- Lighters
- Backup Lighters
- First Aid Kit (trauma)
- Camp Stove
- Camp Stove Fuel
- Water Pot
- Pot Grabber
- Folding Knife
- Fixed-blade Knife
- Knife Sharpening System
- Hatchet
- Axe Sharpening Puck
- Collapsible Saw
- Headlamps
- Multi-tool
- GPS
- Maps
- Watches
- Short Wave Radio
- FMRS Radios (2 or more)
- Extra Batteries
- Toilet Wipes/Toilet Paper
- Soap
- N95 Masks
- Gas Masks
- Lip Balm
- Feminine Hygiene
- Caffeine Tablets
- MREs (Meals Ready to Eat)
- Dehydrated Food (4 days)
- Emergency Rations
- Ground Coffee or Instant
- Creamer
- Spoons, Forks
- Plates
- Cups
- Paper Towels
- Sleeping Bags
- Sleeping Pads
- Gore-Tex Jackets
- Fleeeces/Layer Tops
- Outdoor Pants
- Thermal Underwear*
- Socks
- Beanies
- Boots (worn in)
- Leather Belt
- Sunglasses
- Work Gloves
- Warm Gloves*
- Family Tent
- Camouflage Cover for Tent
- Spare Tire
- Tire Plug Kit
- Tire Repair Aerosol
- Jump Starter
- Tool Set
- Fuel Siphon Kit
- Tow Strap

ON FOOT BUG OUT LIST

- Light Backpack
- Lighter
- Backup Lighter
- Cotton Ball Fire Starter
- Freeze-dried Food
- Energy Snacks
- Light Water Bottle(s)
- Water Treatment Tabs
- Water Filter
- Light Sleeping Bag
- Sleeping Pad
- Emergency Blanket
- Ultralight Stove
- Windscreen for stove
- Stove Fuel
- Backup Stove
- Light Tent
- Tent Stakes
- Light Pocket Knife
- N95 Masks (2) Dust Mask
- Paracord
- Toothbrush
- Toothpaste
- Soap*
- Repellent
- Poop Paper
- Extra Socks (1 or 2 pair)
- Light Pot
- Pot Grabber
- Light Spoon
- Light Headlamp
- Backup Headlamp
- Beanie
- Tourniquet
- Emergency Coffee
- Creamer*
- Maps to your BOL
- Backpack Rain Cover
- Compass
- Water Flavor*
- Potassium Iodide Tabs
- Ibuprofen (4)
- Tylenol (4)
- Antidiarrheal (4)
- Crazy Glue Singles
- 24 in. Duct Tape
- Smart Phone
- Phone Charger
- Drivers License
- Passport
- Fill Water Bottles
- Personal Medicine
- Sunglasses
- Gun(s)
- Holster
- Magazines
- Mag Pouches
- Ammo
- NVGs*
- Feminine Hygiene*
- All Cash Possible
- Sat Phone*

DRESS IN LAYERS,
COMFY BOOTS, AND
DON'T OVER-PACK.
20 POUNDS WITH
WATER, GUNS AND
AMMO.

GRAB AND GO
LIST HEADING
OUT THE DOOR

GO TO
READYMAN.COM
FOR A FREE, DOWNLOAD-
ABLE VERSION.

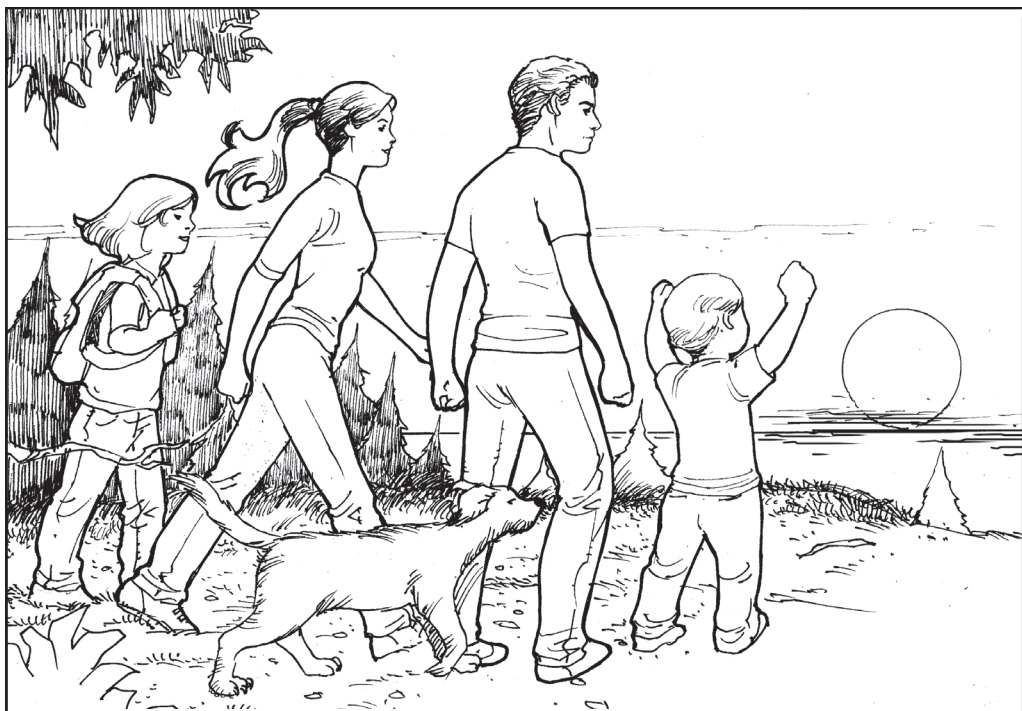

IF IT EVER COMES TO IT, WE WANT YOU TO SURVIVE A BUG OUT. AT **READYMAN**, WE'VE RUN DOZENS OF BUG OUT TESTS WITH STUDLY MEN, FLABBY MEN, VETERANS, ETC., AND WE OFFER SOME HARD TRUTHS PULLED FROM REAL EXPERIENCE, MOSTLY ABOUT GEAR WEIGHT.

OUR PARTING ADVICE IS TO TEST YOUR BUG OUT PLAN. WALK THE ENTIRE ROUTE TO YOUR BUG OUT LOCATION, PREFERABLY WITH YOUR FAMILY, AND AT LEAST ONCE IN BAD WEATHER. CARRY EVERY BIT OF GEAR YOU'RE THINKING OF CARRYING. TEST YOUR PLAN AND LET MOTHER NATURE BE YOUR BUG OUT GUIDE.

BUT MORE THAN ANYTHING, HAVE FUN DOING THIS PREPPING STUFF.

FOR MORE POOR MAN BOOKS, FREE STUFF AND ACCESS TO THE **PLAN2SURVIVE** (THE **ULTIMATE** PREPAREDNESS TOOL) GO TO **READYMAN.COM**.